

Cape May County Municipal Utilities Authority

1523 Route 9 North, Cape May Court House, NJ 08210
Telephone: (609) 465-9026 • Telefax: (609) 465-9025
www.cmcmua.com

REGULAR MEETING AGENDA

September 6, 2023 @ 6:30 p.m.

1. Call to Order
2. Roll Call and Establishment of Quorum
3. Open Public Meeting Statement
4. Pledge of Allegiance
5. Approval of Minutes
 - August 16, 2023 Regular Meeting**
 - August 16, 2023 Executive Session**
6. Comments or Questions from the Public on Agenda Items
7. Announcements/Special Presentations
8. Executive Director's Personnel Report
 - Resignations/Retirements
 - Leaves of Absence and Changes in Leaves of Absence
 - Reassignments/New Hires
9. Board Reports:
 - Treasurer's Report
- **July 31, 2023**
 - Construction Status Report
- **August 30, 2023**
10. Wastewater Management and Solid Waste Management Programs (Combined)
 - Resolution No. 107-23** Resolution Authorizing the Award of a Fair and Open Contract for Professional Services Auditing Services for the Cape May County Municipal Utilities Authority (RFP-39-23) to Ford, Scott & Associates, LLC. (total not-to-exceed amount of \$60,000.00)

11. Wastewater Management Program

Resolution No. 108-23 Resolution Authorizing Contract Change Order No. 1 to Contract OC-18-22 – Ocean City Region 32nd Street Pump Station Piping and Pump Upgrades with Allied Construction Group, Inc.

Resolution No. 109-23 Resolution Authorizing the Award of Contract WW-EQUIP-26-23 – Furnish and Deliver Sludge Collection Components for Various Wastewater Treatment Facilities to Brentwood Industries, Inc. (total not-to-exceed amount of \$863,058.00)

Resolution No. 110-23 Resolution Authorizing the Award of Contract SCF-08-23 – Demolition and Disposal of Various Structures and Equipment at the Sludge Transfer Facility to H4 Enterprises, LLC. (total not-to-exceed amount of \$1,498,847.00)

12. Solid Waste Management Program

Resolution No. 111-23 Resolution Authorizing the Continuation of Contract SW-EQUIP-41-22 with Turbo Systems US Inc. – Furnish and Deliver OEM Replacement Parts, Inspections and Shop Services for ABB Model TPS-52E01 Turbochargers Pursuant to Resolution No. 109-22 (total not-to-exceed amount of \$112,000.00)

Resolution No. 112-23 Resolution Designating Solid Waste Management Program 2021 Excess Revenues

Resolution No. 113-23 Resolution Authorizing the Execution of Agreement for Solid Waste Host Community Benefits to be Provided to the Township of Middle

13. Miscellaneous

Resolution No. 114-23 Resolution Authorizing the Renewal of Membership in the New Jersey Utility Authorities Joint Insurance Fund

Resolution No. 115-23 Resolution Authorizing and Delegating the Cape May County Municipal Utilities Authority's Qualified Purchasing Agent the Ability to Award Contracts having an Anticipated Value in Excess of \$17,500 but Below the Increased Bid Threshold Pursuant to N.J.S.A. 19:44A-20.4

14. Approval of Vouchers – September 6, 2023

Administration
Wastewater Operations
Wastewater Project
Solid Waste Operations
Solid Waste Project

15. Public Comment

16. New Business

17. Executive Session

18. Adjournment

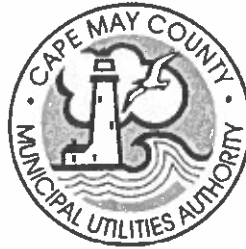

Cape May County Municipal Utilities Authority

1523 Route 9 North Cape May Court House, NJ 08210
Telephone: (609) 465-9026 • Telefax: (609) 465-9025
www.cmcmua.com

MINUTES OF THE REGULAR MEETING

August 16, 2023

Chairman Betts called the regular meeting of the Cape May County Municipal Utilities Authority to order at 1:30 p.m.

PRESENT:

George W. Betts	Chairman
Richard Rixey	Vice Chairman
William G. Burns	Treasurer
Patricia A. Callinan	Corporate Secretary
Carol A. Heenan	Member
Zeth Matalucci	Member
Carol L. Saduk	Member (Absent/Excused)

ALSO PRESENT:

Joseph V. Rizzuto	Executive Director
Thomas J. LaRocco	Chief Engineer
Robert P. Donato	Chief Financial Officer
John R. Conturo	Solid Waste Program Manager
Joshua Palombo	Wastewater Program Manager
Kevin J. Whitney	Senior Advisor
Howard C. Long	Solicitor
Ann M. McDevitt	Recording Secretary

Chairman Betts stated proper notice was given under the provisions of the Open Public Meetings Act.

"Adequate notice of this meeting, in compliance with the Open Public Meetings Act, has been provided for by e-mail to the *Atlantic City Press* and the *Ocean City Sentinel*; and by e-mail to the Cape May County Board of County Commissioners and Cape May County Clerk, and by posting on the Cape May County Bulletin Board and on the Authority's website, all on or before February 13, 2023."

The Pledge of Allegiance was recited.

Minutes

Minutes of the August 2, 2023 Regular Meeting were submitted for approval or correction.

	Motion	Second	Yes	No	Abstain	Absent
Mr. Burns		X	X			
Ms. Callinan	X		X			
Ms. Heenan					X	
Mr. Matalucci					X	
Mr. Rixey			X			
Ms. Saduk						X
Mr. Betts			X			

Motion Carried: 4-0-2

Comments or Questions from the Public on Agenda Items

None offered.

Announcements/Special Presentations

None presented.

Executive Director's Personnel Report

Mr. Rizzuto presented the Executive Director's Personnel Report.

Board Reports

Wastewater Management Program Report – August 9, 2023 – Joshua Palombo

Mr. Palombo presented the Wastewater Management Program Report.

Solid Waste Program Tonnage and Revenue Report – July 2023 – John R. Conturo

Mr. Conturo presented the Solid Waste Tonnage and Revenue Report.

Wastewater Management and Solid Waste Management Programs (Combined)

None presented.

Wastewater Management Program

Resolution No. 101-23 Resolution Authorizing the Award of Contract WWL-EQUIP-18-23 – Furnishing and Delivery of Submersible Mixers to the Wildwood/Lower Wastewater Treatment Facility to Riordan Materials Corporation

	Motion	Second	Yes	No	Abstain	Absent
Mr. Burns	X		X			
Ms. Callinan			X			
Ms. Heenan			X			
Mr. Matalucci			X			
Mr. Rixey		X	X			
Ms. Saduk						X
Mr. Betts			X			

Motion Carried: 6-0-0

Resolution No. 102-23 Resolution Authorizing the Award of Contract WW-EQUIP-22-23 – Furnishing and Delivery of Non Potable Pumps and Appurtenances to the Wildwood/Lower and Seven Mile Beach/Middle Wastewater Treatment Facilities to Mid Atlantic Pump & Equipment Company

	Motion	Second	Yes	No	Abstain	Absent
Mr. Burns	X		X			
Ms. Callinan			X			
Ms. Heenan			X			
Mr. Matalucci			X			
Mr. Rixey		X	X			
Ms. Saduk						X
Mr. Betts			X			

Motion Carried: 6-0-0

Resolution No. 103-23 Resolution Authorizing the Continuation of Contract SER-37-22 with Environmental Protection & Improvement Company, LLC. – Loading, Hauling and Disposal of Dewatered Biosolids for Various CCMUA Wastewater Facilities Pursuant to Resolution No. 94-22

	Motion	Second	Yes	No	Abstain	Absent
Mr. Burns	X		X			
Ms. Callinan			X			
Ms. Heenan			X			
Mr. Matalucci			X			
Mr. Rixey		X	X			
Ms. Saduk						X
Mr. Betts			X			

Motion Carried: 6-0-0

Resolution No. 104-23 Resolution Rescinding Resolution No. 80-23 Authorizing the Withdrawal of the Bid Submitted by Xylem/Espequa Water Technologies for Contract WWL-EQUIP-07-23, Rescinding Resolution No. 81-23 Authorizing the Award of Contract WWL-EQUIP-07-23 to Walker Process Equipment Division of McNish Corp., and Authorizing the Rejection of All Bids Received for WWL-EQUIP-07-23 – Furnishing and Delivery of Rotating Biological Contactors (RBCs) to the Wildwood/Lower Wastewater Treatment Facility and Substantially Revising the Specifications Pursuant to N.J.S.A. 40A:11-13.2(D)

	Motion	Second	Yes	No	Abstain	Absent
Mr. Burns	X		X			
Ms. Callinan			X			
Ms. Heenan			X			
Mr. Matalucci			X			
Mr. Rixey		X	X			
Ms. Saduk						X
Mr. Betts			X			

Motion Carried: 6-0-0

Solid Waste Management Program

Resolution No. 105-23 Resolution Authorizing Shared Services Agreement for Solid Waste Disposal and Recycling Services

	Motion	Second	Yes	No	Abstain	Absent
Mr. Burns	X		X			
Ms. Callinan			X			
Ms. Heenan			X			
Mr. Matalucci			X			
Mr. Rixey		X	X			
Ms. Saduk						X
Mr. Betts			X			

Motion Carried: 6-0-0

Miscellaneous

None presented.

Approval of Vouchers

Approval of the Administration Vouchers List dated August 16, 2023.

	Motion	Second	Yes	No	Abstain	Absent
Mr. Burns	X		X			
Ms. Callinan		X	X			
Ms. Heenan			X			
Mr. Matalucci			X			
Mr. Rixey						
Ms. Saduk						X
Mr. Betts			X			

Motion Carried: 6-0-0

Approval of the Wastewater Operating Vouchers List dated August 16, 2023.

	Motion	Second	Yes	No	Abstain	Absent
Mr. Burns	X		X			
Ms. Callinan		X	X			
Ms. Heenan			X			
Mr. Matalucci			X			
Mr. Rixey			X			
Ms. Saduk						X
Mr. Betts			X			

Motion Carried: 6-0-0

Approval of the Wastewater Project Vouchers List dated August 16, 2023.

	Motion	Second	Yes	No	Abstain	Absent
Mr. Burns	X		X			
Ms. Callinan		X	X			
Ms. Heenan			X			
Mr. Matalucci			X			
Mr. Rixey			X			
Ms. Saduk						X
Mr. Betts			X			

Motion Carried: 6-0-0

Approval of the Solid Waste Operations Vouchers List dated August 16, 2023.

	Motion	Second	Yes	No	Abstain	Absent
Mr. Burns	X		X			
Ms. Callinan		X	X			
Ms. Heenan			X			
Mr. Matalucci			X			
Mr. Rixey			X			
Ms. Saduk						X
Mr. Betts			X			

Motion Carried: 6-0-0

Approval of the Solid Waste Project Voucher List dated August 16, 2023.

	Motion	Second	Yes	No	Abstain	Absent
Mr. Burns	X		X			
Ms. Callinan			X			
Ms. Heenan			X			
Mr. Matalucci			X			
Mr. Rixey			X			
Ms. Saduk						X
Mr. Betts			X			

Motion Carried: 6-0-0

The total of all five (5) approved Vouchers Lists, dated August 16, 2023 was \$2,689,753.67.

Public Comment

None offered.

New Business

None presented.

Executive Session

Resolution No. 106-23 Resolution Authorizing Executive Session from which the Public is Excluded.

	Motion	Second	Yes	No	Abstain	Absent
Mr. Burns	X		X			
Ms. Callinan			X			
Ms. Heenan			X			
Mr. Matalucci			X			
Mr. Rixey		X	X			
Ms. Saduk						X
Mr. Betts			X			

Motion Carried: 6-0-0

At 2:00 p.m., the Regular Meeting retired to Executive Session for the purpose of discussing matters of the long-term Recycling Contract.

At 2:40 pm, it was motioned to end the Executive Session and reconvene to the Regular Meeting.

	Motion	Second	Yes	No	Abstain	Absent
Mr. Burns	X		X			
Ms. Callinan			X			
Ms. Heenan			X			
Mr. Matalucci			X			
Mr. Rixey		X	X			
Ms. Saduk						X
Mr. Betts			X			

Motion Carried: 6-0-0

Adjournment

There being no further business, the Regular Meeting adjourned at 2:40 p.m.

Respectfully submitted,

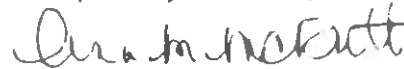

Ann M. McDevitt
Recording Secretary

Joseph V. Rizzuto, Executive Director

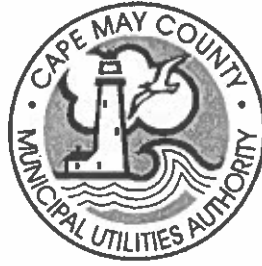

George W. Betts, Chairman
Richard Rixey, Vice Chairman
William G. Burns, Jr.
Patricia A. Callinan
Carol A. Heenan
Zeth Matalucci
Carol L. Saduk

Cape May County Municipal Utilities Authority

1523 Route 9 North Cape May Court House, NJ 08210
Telephone: (609) 465-9026 • Telefax: (609) 465-9025
www.cmcdua.com

MINUTES OF EXECUTIVE SESSION

August 16, 2023

The Cape May County Municipal Utilities Authority held an Executive Session on Wednesday, August 16, 2023 at 2:00 p.m., at the Authority's Office in Swanton, New Jersey, authorized by Resolution No. 106-23.

PRESENT:

George W. Betts	Chairman
Richard Rixey	Vice Chairman
William G. Burns	Treasurer
Patricia A. Callinan	Corporate Secretary
Carol A. Heenan	Member
Zeth Matalucci	Member
Carol L. Saduk	Member (Absent/Excused)

ALSO PRESENT:

Joseph V. Rizzuto	Executive Director
Robert P. Donato	Chief Financial Officer
Thomas J. LaRocco	Chief Engineer
John R. Conturo	Solid Waste Program Manager
Joshua Palombo	Wastewater Program Manager
Kevin J. Whitney	Senior Advisor
Howard C. Long	Solicitor
Ann M. McDevitt	Recording Secretary

The following subject, on which no formal action was taken, was discussed:

Items of Discussion

A discussion was held for the purpose of discussing matters of discussing matters of the long-term Recycling Contract.

Respectfully submitted,

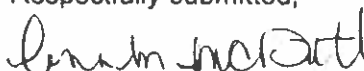
Ann M. McDevitt
Recording Secretary

/amm

RESIGNATIONS/RETIREMENTS

NAME	PROGRAM/POSITION/FACILITY	EFFECTIVE DATE	RESIGNATION or RETIREMENT
Barry D. Johnson	Wastewater/Utility Worker/TVO/Wastewater-TS	8/15/2023	Resignation

LEAVES OF ABSENCE AND CHANGES IN LEAVES OF ABSENCE

NAME	PROGRAM/POSITION/FACILITY	FROM/TO *DENOTES CHANGE	DISABILITY WITH PAY & WITH BENEFITS	FMLA WITH EARNED LEAVE & WITH BENEFITS	FMLA W/O PAY & WITH BENEFITS	FMLA/NJFLA W/O PAY & WITH BENEFITS	NJFLA W/O PAY & WITH BENEFITS	LEAVE W/O PAY & WITH BENEFITS	LEAVE W/O PAY & W/O BENEFITS
ID# 512	Wastewater/Maintenance Worker/Seven Mile	8/21/2023- 9/18/2023		X					

REASSIGNMENTS/NEW HIRES

NAME	FROM PROGRAM/POSITION/FACILITY	TO PROGRAM/POSITION/FACILITY	EFFECTIVE DATE
N/A			



Cape May County Municipal Utilities Authority

Treasurer's Report

for the month ended July 31, 2023

Respectfully Submitted by:

**William G. Burns, Jr.
Treasurer**

Prepared by:

A handwritten signature in black ink, appearing to read "R. Donato", is written over a horizontal line.

**Robert P. Donato, CPA
Chief Financial Officer**



Cape May County Municipal Utilities Authority

Treasurer's Report

for the month ended July 31, 2023

Wastewater Management Program

Administration/Construction Fund

	Trustee-Held Funds <i>TD Wealth Mgmt.</i>	Local Checking Account <i>TD Bank</i>	Local Payroll Account <i>Sturdy</i>	Health Savings Account (Payroll) <i>TD Bank</i>	Total
Balance - July 1, 2023	\$ 1,231,737.27	\$ 199,596.20	\$ 4,834.27	\$ 14,737.49	\$ 1,450,905.23
Cash Receipts					
Interest Income	6,027.97	1,995.42		26.52	8,049.91
Sale of Surplus Equipment					-
NJUI JIF Risk Management Dividend		66,390.00			66,390.00
FEMA Reimbursement - PPE					-
Miscellaneous Reimbursements		2,550.66			2,550.66
Transfers - Expense Reimbursements					
Wastewater Revenue Fund	1,119,741.32				1,119,741.32
Wastewater R&R Fund					-
Wastewater Forward Financing Fund					-
Solid Waste Revenue Fund	657,509.84				657,509.84
Solid Waste Project Fund					-
Total Cash Receipts	\$ 1,783,279.13	\$ 70,936.08	\$ -	\$ 26.52	\$ 1,854,241.73
Cash Disbursements					
Monthly Expenses		978,360.93	612,781.93	3,262.43	1,594,405.29
Transfers - Reimbursement					
Wastewater R&R Fund					-
Transfers - Reimbursement					
Solid Waste Revenue Fund					-
Transfers - Construction Projects					
Wastewater Revenue Fund					-
Transfers - Interest Income					
Wastewater Revenue Fund	6,027.97				6,027.97
Total Cash Disbursements	\$ 6,027.97	\$ 978,360.93	\$ 612,781.93	\$ 3,262.43	\$ 1,600,433.26
Interfund Transfers	(2,338,362.43)	2,338,362.43	(612,781.93)	612,781.93	(3,258.40)
Total Interfund Transfers	\$ (2,338,362.43)	\$ 1,722,322.10	\$ 612,781.93	\$ 3,258.40	\$ -
Balance - July 31, 2023	\$ 670,626.00	\$ 1,014,493.45	\$ 4,834.27	\$ 14,759.98	\$ 1,704,713.70



Cape May County Municipal Utilities Authority

Treasurer's Report

for the month ended July 31, 2023

Wastewater Management Program

Project Fund

	Trustee-Held Funds Renewal and Replacement Fund <i>TD Wealth Mgmt.</i>	Local Checking Account <i>TD Bank</i>	Total
Balance - July 1, 2023	<u>\$ 48,284,283.19</u>	<u>\$ 79,160.09</u>	<u>\$ 48,363,443.28</u>
Cash Receipts			
Interest Income	189,837.30	1,004.80	190,842.10
Borough of Woodbine - Reimbursement		3,658.57	3,658.57
Transfers - Expense Reimbursements			
Wastewater Construction Fund			-
Wastewater Revenue Fund			-
Total Cash Receipts	<u>\$ 189,837.30</u>	<u>\$ 4,663.37</u>	<u>\$ 194,500.67</u>
Cash Disbursements			
Monthly Expenses		1,063,256.85	1,063,256.85
Transfers - Expense Reimbursements			
Wastewater Construction Fund			-
Wastewater Revenue Fund			-
Transfers - Interest Income			
Wastewater Revenue Fund	189,837.30		189,837.30
Total Cash Disbursements	<u>\$ 189,837.30</u>	<u>\$ 1,063,256.85</u>	<u>\$ 1,253,094.15</u>
Interfund Transfers	<u>(1,063,256.85)</u>	<u>1,063,256.85</u>	<u>-</u>
Total Interfund Transfers	<u>\$ (1,063,256.85)</u>	<u>\$ 1,063,256.85</u>	<u>\$ -</u>
Balance - July 31, 2023	<u>\$ 47,221,026.34</u>	<u>\$ 83,823.46</u>	<u>\$ 47,304,849.80</u>



Cape May County Municipal Utilities Authority

Treasurer's Report

for the month ended July 31, 2023

Wastewater Management Program

Revenue Fund

	Trustee-Held Funds <i>TD Wealth Mgmt.</i>	Local Checking Account <i>TD Bank</i>	Local Daily Deposit Account <i>TD Bank</i>	Total
Balance - July 1, 2023	\$ 16,698,610.85	\$ 94,043.73	\$ 6,958.95	\$ 16,799,613.53
Cash Receipts				
Revenue				
User Charges			43,814.25	43,814.25
Septage/Leachate			87,015.36	87,015.36
Sludge Processing			37,519.93	37,519.93
Tower Rental			14,727.08	14,727.08
Insurance Claims				-
Miscellaneous Reimbursements			1,317.60	1,317.60
Interest Income	50,782.27	635.46	30.96	51,448.69
Transfers - Interest Income				
Wastewater Accounts				
General Fund	10,756.11			10,756.11
Renewal and Replacement	189,837.30			189,837.30
Construction Fund	6,027.97			6,027.97
2002 Forward Financing	1,093.37			1,093.37
Rate Stabilization Fund	44.30			44.30
Transfers - Other				
Construction Fund - Projects				-
Bond Reserve Fund				-
Renewal and Replacement Fund				-
Solid Waste Revenue Fund				-
Solid Waste Project Fund				-
Total Cash Receipts	\$ 258,541.32	\$ 635.46	\$ 184,425.18	\$ 443,601.96
Cash Disbursements				
Monthly Expenses		265,940.90		265,940.90
Transfers - Expense Reimbursements				
Wastewater Construction Fund	1,119,741.32			1,119,741.32
Wastewater Bond Service Fund				-
Renewal and Replacement Fund				-
Solid Waste Future Construction Reserve				-
Total Cash Disbursements	\$ 1,119,741.32	\$ 265,940.90	\$ -	\$ 1,385,682.22
Interfund Transfers	176,655.07 (265,865.51)	265,865.51	(176,655.07)	-
Total Interfund Transfers	\$ (89,210.44)	\$ 265,865.51	\$ (176,655.07)	\$ -
Balance - July 31, 2023	\$ 15,748,200.41	\$ 94,603.80	\$ 14,729.06	\$ 15,857,533.27



Cape May County Municipal Utilities Authority

Treasurer's Report

for the month ended July 31, 2023

Solid Waste Management Program

Project Fund

	Trustee-Held Funds <i>TD Wealth Mgmt.</i>	Local Checking Account <i>TD Bank</i>	Trustee-Held Funds Future Construction Reserve Fund <i>TD Wealth Mgmt.</i>	Total
Balance - July 1, 2023	\$ 584,412.95	\$ 90,643.41	\$ 13,602,240.78	\$ 14,277,297.14
Cash Receipts				
Interest Income	2,160.19	218.82	54,988.55	57,367.56
Transfers - Expense Reimbursements				
Solid Waste Equipment Reserve				-
Solid Waste Closure Fund				-
Solid Waste IPF Capital Reserve Fund				-
Solid Waste Building and Site Fund				-
Solid Waste Revenue Fund			62,500.00	62,500.00
Wastewater Revenue Fund				-
Total Cash Receipts	\$ 2,160.19	\$ 218.82	\$ 117,488.55	\$ 119,867.56
Cash Disbursements				
Monthly Expenses		79,043.48		79,043.48
Transfers - Expense Reimbursements				
Wastewater Construction Fund				-
Wastewater Revenue Fund				-
Transfers - Closure-related Expenditures				
Solid Waste Revenue Fund				-
Transfers - Rate Stabilization				
Solid Waste Revenue Fund				-
Transfers - Debt Service-related Expenditures				
Solid Waste Revenue Fund				-
Transfers - Interest Income				
Solid Waste Revenue Fund	2,160.19		54,988.55	57,148.74
Total Cash Disbursements	\$ 2,160.19	\$ 79,043.48	\$ 54,988.55	\$ 136,192.22
Interfund Transfers	79,043.48 (79,043.48)	79,043.48	(79,043.48)	-
Total Interfund Transfers	\$ -	\$ 79,043.48	\$ (79,043.48)	\$ -
Balance - July 31, 2023	\$ 584,412.95	\$ 90,862.23	\$ 13,585,697.30	\$ 14,260,972.48



Cape May County Municipal Utilities Authority

Treasurer's Report

for the month ended July 31, 2023

Solid Waste Management Program

Revenue Fund

	Trustee-Held Funds <i>TD Wealth Mgmt.</i>	Local Checking Account <i>TD Bank</i>	Local Daily Deposit Account <i>TD Bank</i>	Prepayment Account <i>TD Bank</i>	Total
Balance - July 1, 2023	\$ 6,743,708.18	\$ 98,019.89	\$ 66,497.21	\$ 154,120.11	\$ 7,062,345.39
Cash Receipts					
Revenue					
Tipping Fees			1,820,326.39		1,820,326.39
Wood Products			67,917.37		67,917.37
Methane Revenue					-
Recycling Enhancement Grant					-
Electricity Generation			(59.73)		(59.73)
Property Rental			1,000.00		1,000.00
Sale of Surplus Assets			28,185.00		28,185.00
Insurance Reimbursement					-
Miscellaneous Reimbursements					-
Prepayments Received					-
Interest Income	24,392.74	570.19	213.30	254.65	25,430.88
Transfers - Interest Income					
Solid Waste Accounts					
Equipment Reserve Fund	257.40				257.40
Building and Site Improvements	899.07				899.07
Host Community Benefit Reserve	1,569.06				1,569.06
General Fund	61.67				61.67
Future Construction Reserve	54,988.55				54,988.55
Project Fund	2,160.19				2,160.19
Transfers - Expense Reimbursements					
Wastewater Construction Fund					-
Building and Site Improvement Fund					-
Solid Waste Project Fund					-
Future Construction Reserve Fund					-
IPF Capital Reserve Fund					-
IPF Rate Stabilization Fund	154,471.90				154,471.90
Host Community Benefit Fund					-
Total Cash Receipts	\$ 238,800.58	\$ 570.19	\$ 1,917,582.33	\$ 254.65	\$ 2,157,207.75
Cash Disbursements					
Monthly Expenses		650,589.97	2,942.87		653,532.84
Prepayments Returned				25,187.23	25,187.23
Transfers - Expense Reimbursements					
Wastewater Construction Fund	657,509.84				657,509.84
Wastewater Revenue Fund					-
Solid Waste Project Fund					-
Transfers - Reserve Accounts					
Equipment Reserve Fund					-
Closure Fund	16,991.07				16,991.07
Host Community Benefit Fund	94,380.38				94,380.38
Building and Site Improvement Fund					-
Future Construction Reserve Fund	62,500.00				62,500.00
Debt Service Fund					-
IPF Rate Stabilization Fund					-
IPF Capital Reserve Fund					-
Total Cash Disbursements	\$ 831,381.29	\$ 650,589.97	\$ 2,942.87	\$ 25,187.23	\$ 1,510,101.36
Interfund Transfers	1,751,051.42 (650,589.97)	650,589.97	(1,751,051.42)		-
Total Interfund Transfers	\$ 1,100,461.45	\$ 650,589.97	\$ (1,751,051.42)	\$ -	\$ -
Balance - July 31, 2023	\$ 7,251,588.92	\$ 98,590.08	\$ 230,085.25	\$ 129,187.53	\$ 7,709,451.78



Cape May County Municipal Utilities Authority

Treasurer's Report

for the month ended July 31, 2023

Wastewater Management Program

Investment Summary

Account Name / Bank	Purchase Date	Maturity Date	Interest Rate	Amount
Construction Fund				
New Jersey Cash Management Fund			5.12%	\$ 670,626.00
TD Bank - Checking			2.20%	1,014,493.45
TD Bank - Health Savings Account			2.20%	14,759.98
Sturdy Savings - Payroll			-	4,834.27
				\$ 1,704,713.70
Revenue Fund				
TD Bank - Money Market			2.20%	\$ 161,773.46
New Jersey Cash Management Fund			5.12%	13,982,522.83
Parke Bank - Money Market			4.75%	381,837.82
New Jersey Asset & Rebate Management Fund (NJ/ARM)			5.18%	1,222,066.30
TD Bank - Daily Deposit			2.20%	14,729.06
TD Bank - Checking			2.20%	94,603.80
				\$ 15,857,533.27
General Fund				
New Jersey Cash Management Fund			5.12%	\$ 365,675.23
Parke Bank - Money Market			4.75%	2,500,000.00
				\$ 2,865,675.23
Renewal and Replacement Fund				
Parke Bank - Money Market			4.75%	12,626,771.85
New Jersey Asset & Rebate Management Fund - (NJ/ARM)			5.18%	29,749,016.98
TD Bank - Money Market			2.20%	4,605,361.89
New Jersey Cash Management Fund			5.12%	239,875.62
TD Bank - Checking			2.20%	83,823.46
				\$ 47,304,849.80



Cape May County Municipal Utilities Authority

Treasurer's Report

for the month ended July 31, 2023

Wastewater Management Program

Investment Summary (continued)

<u>Account Name / Bank</u>	<u>Purchase Date</u>	<u>Maturity Date</u>	<u>Interest Rate</u>	<u>Amount</u>
Rate Stabilization Fund				
New Jersey Cash Management Fund			5.12%	\$ 10,811.47
				<u>\$ 10,811.47</u>
Sick and Vacation Pay Reserve Fund				
New Jersey Cash Management Fund			5.12%	\$ 337,987.07
				<u>\$ 337,987.07</u>
2002 Forward Financing Fund				
New Jersey Cash Management Fund			5.12%	\$ 269,259.47
				<u>\$ 269,259.47</u>
Bond Service Fund				
TD Bank - Money Market			2.20%	
				<u>\$ -</u>

Total Funds - Wastewater Management Program \$ 68,350,830.01



Cape May County Municipal Utilities Authority

Treasurer's Report

for the month ended July 31, 2023

Solid Waste Management Program

Investment Summary

<u>Account Name / Bank</u>	<u>Purchase Date</u>	<u>Maturity Date</u>	<u>Interest Rate</u>	<u>Amount</u>
Project Fund				
TD Bank - Money Market			2.20%	\$ 2,815.77
Parke Bank - Money Market			4.75%	581,597.18
TD Bank - Checking			2.20%	90,862.23
				<u>\$ 675,275.18</u>
Revenue Fund				
TD Bank - Money Market			2.20%	\$ 59,250.62
Parke Bank - Money Market			4.75%	134,449.54
New Jersey Cash Management Fund			5.12%	4,725,323.22
New Jersey Asset & Rebate Management Fund (NJ/ARM)			5.18%	2,332,565.54
TD Bank - Prepayment Account			-	129,187.53
TD Bank - Daily Deposit			2.20%	230,085.25
TD Bank - Checking			2.20%	98,590.08
				<u>\$ 7,709,451.78</u>
Equipment Reserve Fund				
New Jersey Cash Management Fund			5.12%	\$ 65,044.12
				<u>\$ 65,044.12</u>
Building and Site Improvement Fund				
Parke Bank - Money Market			4.75%	\$ 242,631.44
				<u>\$ 242,631.44</u>
Insurance Reserve Fund				
New Jersey Cash Management Fund			5.12%	\$ 20,995.83
Parke Bank - Money Market			4.75%	618,117.01
				<u>\$ 639,112.84</u>



Cape May County Municipal Utilities Authority

Treasurer's Report

for the month ended July 31, 2023

Solid Waste Management Program

Investment Summary (continued)

<u>Account Name / Bank</u>	<u>Purchase Date</u>	<u>Maturity Date</u>	<u>Interest Rate</u>	<u>Amount</u>
Rate Stabilization Fund				
New Jersey Cash Management Fund			5.12%	\$ 902,769.03
				\$ 902,769.03
IPF Rate Stabilization Fund				
New Jersey Cash Management Fund			5.12%	\$ 1,506,867.76
				\$ 1,506,867.76
IPF Capital Reserve Fund				
New Jersey Cash Management Fund			5.12%	\$ 654,082.65
				\$ 654,082.65
Closure Fund				
US Government Issues		average	2.17%	\$ 7,688,196.97
US Government Agency Issues		average	2.25%	78,537.95
First American Government Obligation Fund			5.24%	12,496.73
				\$ 7,779,231.65
<i>The Closure Fund is administered by US Bank under an NJDEP-stipulated Escrow Agreement</i>				
Host Community Benefit Reserve Fund				
New Jersey Cash Management Fund			5.12%	\$ 503,850.49
				\$ 503,850.49



Cape May County Municipal Utilities Authority

Treasurer's Report

for the month ended July 31, 2023

Solid Waste Management Program

Investment Summary (continued)

<u>Account Name / Bank</u>	<u>Purchase Date</u>	<u>Maturity Date</u>	<u>Interest Rate</u>	<u>Amount</u>
Debt Service Fund - NJEIT Series				
New Jersey Cash Management Fund			5.12%	\$ -
Parke Bank - Money Market			4.75%	\$ -
				<u>\$ -</u>
Project Fund II - State Grant				
New Jersey Cash Management Fund			5.12%	\$ 304,908.58
				<u>\$ 304,908.58</u>
General Fund				
Parke Bank - Money Market			4.75%	\$ 16,644.13
				<u>\$ 16,644.13</u>
Future Construction Reserve Fund				
Parke Bank - Money Market			4.75%	\$ 6,085,697.30
New Jersey Asset & Rebate Management Fund - (NJ/ARM)			5.18%	\$ 7,500,000.00
				<u>\$ 13,585,697.30</u>

Total Funds - Solid Waste Management Program \$ 34,585,566.95



Cape May County Municipal Utilities Authority

Treasurer's Report

for the month ended July 31, 2023

Cash Management Plan Compliance Statements

1. Securities Purchased or Sold/Matured during the Reporting Period - ***

Purchased

None

Matured

None

2. Summary of Securities Owned - ***

None

3. Interest Received during the Reporting Period - ***

<u>Program</u>	<u>Securities</u>	<u>Other</u>	<u>Total</u>
Wastewater	\$ -	\$ 263,608.56	\$263,608.56
Solid Waste	-	102,632.95	102,632.95
Total	\$ -	\$ 366,241.51	\$366,241.51

4. Fees Incurred during the Reporting Period - ***

<u>Program</u>	<u>Securities</u>	<u>Other</u>	<u>Total</u>
Wastewater	\$ -	\$ -	\$ -
Solid Waste	-	-	-



Cape May County Municipal Utilities Authority

Treasurer's Report

for the month ended July 31, 2023

Cash Management Plan Compliance Statements (continued)

5. Summary of Funds as of July 31, 2023

<u>Official Depositories</u>	<u>Wastewater</u>	<u>Solid Waste</u>	<u>Total</u>
Parke Bank	\$ 15,508,609.67	\$ 7,679,136.60	\$ 23,187,746.27
Sturdy Savings Bank	4,834.27	-	4,834.27
TD Bank NA	5,989,545.10	610,791.48	6,600,336.58
<u>Other Official Funds</u>			
New Jersey Cash Management	15,876,757.69	8,683,841.68	24,560,599.37
New Jersey Asset and Rebate Management Fund	30,971,083.28	9,832,565.54	40,803,648.82
	<u>\$ 68,350,830.01</u>	<u>\$ 26,806,335.30</u>	<u>\$ 95,157,165.31</u>
Closure Fund ***	<u>-</u>	<u>7,779,231.65</u>	<u>7,779,231.65</u>
Total Funds	<u>\$ 68,350,830.01</u>	<u>\$ 34,585,566.95</u>	<u>\$102,936,396.96</u>

***** The Closure Fund is administered by US Bank under an NJDEP-stipulated Escrow Agreement**

MEMORANDUM

August 30, 2023

TO: Mr. Joseph V. Rizzuto, Executive Director

FROM: Thomas J. LaRocco, P.E., Chief Engineer 

RE: Construction Status Report

The following is a summary status report of the Authority's on-going projects for the period July 27, 2023 through August 30, 2023.

° **Project:** Contract No. OC-18-22
Ocean City Region
32nd Street Pump Station Piping & Pump Upgrades

Contractor: Allied Construction

The purpose of this project is to replace piping, fittings, valves and appurtenances on the dry side of the well to remediate poor material conditions, and to improve the operational flexibility of the station. The installation of three (3) new sets of pumps and motors that were procured independently of this contract shall also be completed. This project was awarded on November 16th. Notice to Proceed was issued, effective December 5, 2022. A preconstruction meeting was held on December 13th. It is expected that, due to seasonal flow conditions and supply chain problems, the Contractor will not begin physical work until October 15, 2023. Currently, the review of technical submittals and material procurement is ongoing.

Contract Amount: \$1,781,000.00
Paid to Date: \$ 0.00
Completion Date: April 10, 2024

° **Project:** Contract No. SM-55-22
Seven Mile Beach/Middle Region
Furnish and Install Backflow Preventer Units

Contractor: West Bay Construction, Inc.

The purpose of this project is to install facility-wide backflow preventer and bypass systems for two potable water services, both fire and domestic, that serve the facility. The goal is to prevent contamination of the municipal water distribution system from the facility's water system while also eliminating the need for several internal backflow preventer permits. The backflow preventer and bypass systems are to be housed in a new, small, precast concrete, pre-engineered building which shall be located immediately west of the facility's entrance. The precast concrete building was delivered on August 15th. Erection was completed by August 16th. On August 18th, downspouts and gutters were installed and the backflow preventers were delivered to the site. The Contractor expects to complete interior plumbing work and the connection to the existing water lines by mid-September. The long lead time associated with the building's delivery will most likely require an extension of contract time.

Contract Amount: \$525,000.00
Paid to Date: \$235,920.40
Completion Date: August 19, 2023

MEMORANDUM

August 30, 2023

Page 2

° **Project:** Contract No. WW/L-02-23
Wildwood/Lower Region
Furnish and Install New Centrifugal Blowers

Contractor: Municipal Maintenance Company, Inc.

The purpose of this project is to replace three of four existing blowers, and to provide new controls to the three new blowers and the single, existing rebuilt blower. These blowers provide process air to the facility's entire treatment system. Two (2) of the new blowers will have capacities that are less than those of the original units so as to more efficiently accommodate off-season demands. This project was awarded on March 1, 2023. Notice to Proceed was issued, effective March 22, 2023. A preconstruction meeting was held on April 5, 2023. It is expected that, due to seasonal flow conditions and lead time requirements, the Contractor will not begin physical work until September 15, 2023. Currently, the review of technical submittals and material procurement is ongoing.

Contract Amount: \$1,381,377.00
Paid to Date: \$ 0.00
Completion Date: May 21, 2024

° **Project:** Contract No. WW-11-23
Various Regions
Disposal of RBCs and Other Miscellaneous Equipment

Contractor: Garton's Rigging, Inc.

The purpose of this project is to remove and dispose of various pieces of surplus equipment that are in poor condition in order to provide more working space at the Authority's Ocean City, Wildwood/Lower and Cape May Wastewater Treatment Facilities. Work includes the loading, hauling, unloading and disposal of nineteen (19) RBC shaft assemblies, two (2) storage tanks and, on an "if and where directed" basis, eight (8) storage containers and other miscellaneous treatment equipment. All assigned pay item work has been completed. This Contract shall be extended past the June 20th completion date to enable the Authority to utilize the remaining funds from this Contract's "Allowance" pay item to be dedicated to the installation of three (3) RBCs at Ocean City, scheduled for this coming winter.

Contract Amount: \$269,125.00
Paid to Date: \$202,976.68
Completion Date: June 20, 2023

TJL:amm

cc: Authority Members
Mr. Robert P. Donato, CPA
Mr. Joshua Palombo
Mr. John R. Conturo, P.E.
Ms. Ann M. McDevitt



Assembling building walls (8-15-23)



Lifting roof section into place (8-15-23)

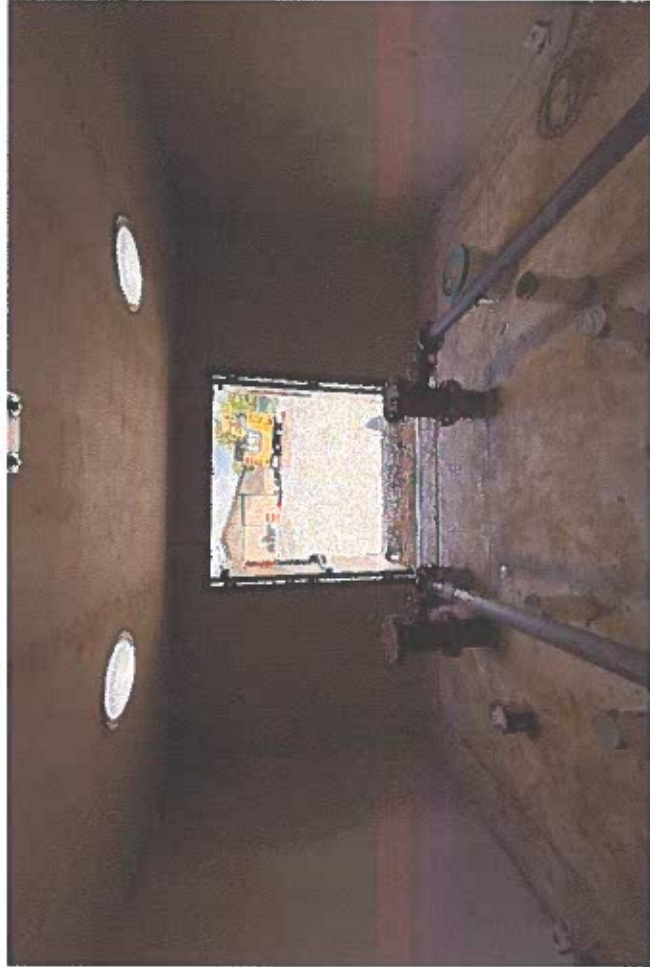

Inside looking out (8-16-23)



Building complete (8-18-23)

Cape May County Municipal Utilities Authority

RESOLUTION NO. 107-23

RESOLUTION AUTHORIZING THE AWARD OF A FAIR AND OPEN CONTRACT FOR PROFESSIONAL SERVICES AUDITING SERVICES FOR THE CAPE MAY COUNTY MUNICIPAL UTILITIES AUTHORITY (RFP-39-23) TO FORD, SCOTT & ASSOCIATES, LLC

WHEREAS, the Cape May County Municipal Utilities Authority ("CMCMUA"/"Authority") has a need for Professional Auditing Services; and,

WHEREAS, the CMCMUA, on August 9, 2023, advertised a Request for Proposals, RFP-39-23, entitled "Professional Services Auditing Services for the Cape May County Municipal Utilities Authority" ("RFP"); and,

WHEREAS, Proposals were received from two (2) Auditing Firm; and,

WHEREAS, Ford, Scott & Associates, LLC submitted a Proposal on August 24, 2023 in response to the Authority's RFP solicited pursuant to the New Jersey Local Pay-to-Play Law (N.J.S.A. 19:44A-20.4 et. seq.) to provide said services in accordance with the schedule of rates contained therein; and,

WHEREAS, following evaluation of the Proposals that met the minimum qualifications of the RFP, the Authority's Review Committee has identified Ford, Scott & Associates, LLC, 1535 Haven Avenue, Ocean City, NJ 08226 as a firm which best meets the auditing needs of the CMCMUA under the RFP; and,

WHEREAS, Ford, Scott & Associates, LLC has warranted that it is ready, willing and able to perform all necessary services and that it and/or members of its firm hold in good standing all of the necessary licenses for the lawful performance of said services within the State of New Jersey; and,

WHEREAS, the Authority desires to retain the services of Ford, Scott & Associates, LLC for the purpose of providing Auditing Services detailed in the RFP in accordance with the schedule of rates contained in their Proposal; and,

WHEREAS, the Local Public Contracts Law at N.J.S.A. 40A:11-5(1)(a)(i) requires that the Resolution authorizing the award of contracts for "Professional Services" without competitive bids, and the contract itself, must be available for public inspection; and,

WHEREAS, the Authority's Chief Financial Officer will certify that funds are available prior to authorizing each Purchase Order for said services.

NOW, THEREFORE, BE IT RESOLVED by the Cape May County Municipal Utilities Authority that it hereby awards a Professional Services Contract to Ford, Scott & Associates, LLC to perform Professional Auditing Services in accordance with a Proposal submitted by said firm on August 24, 2023, the provisions therein to be incorporated into a contract to be executed and filed with the Authority's Office Manager.

BE IT FURTHER RESOLVED by the Cape May County Municipal Utilities Authority, a body corporate and politic, as follows:

1. The provisions of the WHEREAS clauses set forth above are incorporated herein by reference and made a part hereof.

2. The Authority's Executive Director, or Deputy Director, is hereby authorized to execute an Agreement for Professional Services with the auditing firm of Ford, Scott & Associates, LLC. The Agreement shall be consistent with the Authority's Request for Proposals dated August 9, 2023 and the Proposal submitted on August 24, 2023 by Ford, Scott & Associates, LLC.
3. Ford, Scott & Associates, LLC shall be compensated within a not-to-exceed Budget of \$50,000.00 to prepare the 2023 Annual Audit Report; prepare the 2023 Annual Landfill Closure Escrow Fund Audit Report; any additional audit requirements as contained in the Federal Single Audit Act of 1984; and provide assistance to the CMCMUA Staff in the preparation and submission of the Authority's proposed Wastewater and Solid Waste Budgets for Fiscal Year 2023. An additional Supplemental Services Budget in the not-to-exceed amount of \$10,000.00 is approved for the conduct of additional non-routine audit or accounting requirements, to be authorized by the Authority's Executive Director or Chief Financial Officer, on an as-needed basis, and reimbursed based on the Auditor's established hourly time charges as contained in the Proposal submitted by Ford, Scott & Associates, LLC on August 24, 2023.
4. The term of this contract shall be September 1, 2023 through August 31, 2024.
5. This Contract is awarded without competitive bidding as a professional service pursuant to N.J.S.A. 40A:11-5(1)(a)(i) of the Local Public Contracts Law, since the Contract involves services performed by persons authorized by law to practice a recognized profession.
6. This Contract is awarded through a fair and open process pursuant to N.J.S.A 19:44A-20.4 et seq. of the Local Unit Pay-To-Play Law.
7. A copy of this Resolution, or a notice thereof, shall be published in an official Authority newspaper.
8. The Contract executed by authority of this Resolution will be made available for public inspection.

BE IT FURTHER RESOLVED in accordance with N.J.A.C. 5:30-5.5(b)2, no amount of Professional Services Auditing Services under Contract RFP-39-23 shall be chargeable or certified until such time as they are actually ordered or otherwise called for. Prior to authorizing any work under this Contract, a certification of available funds shall be made by the Authority's Chief Financial Officer upon receipt of a properly executed Purchase Order and said certification shall be attached to the file copy of the Purchase Order. Total expenditures under this contract shall not exceed \$60,000.00.

	Motion	Second	Yes	No	Abstain	Absent
Mr. Burns						
Ms. Callinan						
Ms. Heenan						
Mr. Matalucci						
Mr. Rixey						
Ms. Saduk						
Mr. Betts						

I hereby certify the foregoing to be a true and correct copy of Resolution No. **107-23** adopted by the Cape May County Municipal Utilities Authority at its Regular Meeting on the **6th** day of **September 2023**.

Assistant Corporate Secretary

CAPE MAY COUNTY MUNICIPAL UTILITIES AUTHORITY

CONTRACT FACT SHEET

PROJECT INFORMATION

Project Name: Professional Services – Auditing Services

Purpose and Scope of Contract: The auditing firm, having auditors licensed in the State of New Jersey as certified public accountants and registered municipal accountants, will serve as the Authority's independent auditor. The firm will audit the financial statements of the Authority's Landfill Closure Escrow Fund as of September 30, 2023, and will audit the Authority's basic financial statements as of December 31, 2023. The auditing firm may be called upon to provide general consulting services, including, but not limited to, annual budget preparation, current and future bond indebtedness, and cash flow analyses.

PROCUREMENT INFORMATION

Contract Type: Procurement (Goods and Services) Professional Services
 Construction Non-Professional Services

Contract Number: RFP-39-23 **Term of Contract:** One (1) Year **Option to Renew:** No Yes:

Bid Guarantee: No Yes **Consent of Surety:** No Yes

Liquidated Damages: No Yes: ,Basis:

Engineer's Estimate: \$60,000.00

Advertisement Date: August 9, 2023 **Opening Date:** August 24, 2023

Contract Award Basis: Lowest Responsible Bidder Best Value Cooperative Pricing System
 Highest Ranking Score Negotiated

Recommendation: Award
 Exercise 1 year option to renew under original Contract Terms and Conditions, Option Dates: ;
 Options to Renew remaining:
 Reject, Basis:

CONTRACTOR/VENDOR INFORMATION

Contractor/Vendor: Ford Scott & Associates, LLC.

Address: 1535 Haven Avenue
 Ocean City, NJ 08226

BUDGET INFORMATION

Program: Wastewater Solid Waste Administration

Funding:

Operating Budget Capital SW Building & Site Maintenance SW Equipment Fund

Contract Value, Not-To-Exceed: \$60,000.00

Contract Spending Previous Contract Year: \$44,278.00

 Kevin W. McGahey, Purchasing Agent

08-31-2023 
 Date Joshua Palombo, WW Program Manager

8/29/23
 Date

 John R. Conturo, SW Program Manager

8/30/2023 
 Date Robert P. Donato, Chief Financial Officer

8/31/2023
 Date

 Joseph V. Rizzuto, Executive Director

08/29/23
 Date

Cape May County Municipal Utilities Authority

RESOLUTION NO. 108-23

**RESOLUTION AUTHORIZING CONTRACT CHANGE ORDER NO. 1 TO
CONTRACT OC-18-22 – OCEAN CITY REGION 32ND STREET PUMP STATION PIPING
AND PUMP UPGRADES WITH ALLIED CONSTRUCTION GROUP, INC.**

BE IT RESOLVED by the Members of the Cape May County Municipal Utilities Authority ("CMCMUA"/"Authority") that the following Change Order, recommended by the CMCMUA's Chief Engineer, regarding Contract WW-18-22 – Ocean City Region 32nd Street Pump Station Piping and Pump Upgrades with Allied Construction Group, Inc. is hereby approved:

A. Change Order No. 1

Net Change in Contract Amount: Decrease total amount by \$95,367.16.

Work Involved: This Change Order represents a decrease in the total Contract Amount to account for credits to Bid Item 5, Provision and Installation of Contractor Supplied Suction Discharge, Manifold Piping, Fittings, Valves and Appurtenances, and Bid Item 10, By-Pass Pumping, and an increase in Bid Item 11, Contingency Allowance for Unseen Conditions (if and where directed).

Impact on Contract Schedule: No Change

BE IT FURTHER RESOLVED, that the Authority's Executive Director or Deputy Director are authorized to execute any documents necessary to complete this authorization.

	Motion	Second	Yes	No	Abstain	Absent
Mr. Burns						
Ms. Callinan						
Ms. Heenan						
Mr. Matalucci						
Mr. Rixey						
Ms. Saduk						
Mr. Betts						

I hereby certify the foregoing to be a true and correct copy of Resolution No. **108-23** adopted by the Cape May County Municipal Utilities Authority at its Regular Meeting on the **6th** day of **September 2023**.

Assistant Corporate Secretary

**CAPE MAY COUNTY MUNICIPAL UTILITIES AUTHORITY
CONTRACT CHANGE ORDER FACT SHEET**

PROJECT INFORMATION

Program: Wastewater Solid Waste Administration

Funding: Operating Budget Capital SW Building & Site Maintenance SW Equipment Fund

Project Name/Contract Number: Ocean City Region 32nd Street Pump Station Piping and Pump Upgrades
(Contract OC-18-22)

Original Purpose and Scope of Contract: The scope of this Contract is for the installation of 12", 14", 20" and 24" piping, fittings, valves, and meters to provide wet well isolation reducing the need for full bypass pumping. This configuration will allow for use of the second 12" force main discharging prior to 46th Street Pump Station. The 12" force main provides staff with operational flexibility in emergencies and can be used as a temporary bypass of the existing 24" force main. This project also includes installation of three (3) newly purchased Immersible Motor and Pumps and the reinstallation of an existing pump for a total of 4 pumps providing additional redundancy. All electrical work will be performed by CMCMA work forces.

CONTRACTOR/VENDOR INFORMATION

Contractor/Vendor: Allied Construction Group, Inc

Address: 499 Washington Road
Parlin, New Jersey 08859

CHANGE ORDER INFORMATION

Change Order Number: 1

Change Order Scope: The purpose of this change order is to decrease the contract amount by \$95,367.16, which is the sum of the reduction of line Item 5 and line Item 10, \$9,431.00 and \$135,936.16, respectfully, and an increase in line Item 11 of \$50,000.00, such that the Contract Amount will decrease from \$1,781,000.00 to \$1,685,632.84.

Change Order Description:

Item 5: Provision and Installation of Contractor Supplied Suction Discharge, Manifold Piping, Fittings, Valves and Appurtenances

The 32nd Street Pumping station on August 10, 2022 started leaking at a 24"x24"x14" wye fitting in the discharge manifold, whereas the Authority Executive Director declared it as an emergency and the Authority Staff contracted with Municipal Maintenance Company to perform the repair under an emergency contract. The fitting that failed was not a stock shelf fitting and was a long lead item. The contractor installed a temporary spool piece and ordered the fitting to be installed at a later time by others. The fitting was not delivered prior to this contract being bid. During the shop drawing review process, we were made aware that the fitting was delivered. The Authority contacted the Contractor and offered it for use. The contractor submitted a credit quote of \$9,431.00 to use this fitting. Authority staff determined the credit to be fair and reasonable. This reduced this line item from \$500,00.00 to \$490,569.00.

Item 10: By-Pass Pumping

The Contractor submitted a bypass plan for review and approval as required by the bid specifications. During the review it was observed that several requirements were modified. The specifications; however, do allow for deviation, subject to approval by the Authority. More specifically, the bypass system was to be manned during operation, and the contractor was required to supply whatever source of power was required to operate the bypass pumps, whether diesel or electric. The submitted plan requested use of the power from the pump station and a telemetry system in lieu of manning the system 24 hours, 7 days a week. Authority Staff took no exception to the submittal and requested credit for the reduced scope. The contractor offered \$135,936.16 credit for eliminating the bypass watch personnel, and for the diesel fuel they would have used during the bypass operations. Authority staff determined the credit to be fair and reasonable. This reduced this line item from \$810,000.00 to \$674,063.84

Item 11: Contingency Allowance for unforeseen Conditions (if and where directed) \$100,000

It was expected that miscellaneous conditions would be discovered that would require immediate attention once the pump station is by-passed and various existing piping and mechanical appurtenances were dismantled. As a result, this pay item was established such that the necessary work could be done on an "if and Where Directed" basis to avoid delays and safety concerns. To date, \$45,339.00 of the \$100,000.00 allowance amount has been dedicated or encumbered to resolve unforeseen problems that have been encountered during the contractor's required piping verification inspection prior to construction. Since the construction phase has not yet started, it is recommended that the amount of this pay item be increased by \$50,000.00 This increases this line item from \$100,000.00 to \$150,000.00.

**CAPE MAY COUNTY MUNICIPAL UTILITIES AUTHORITY
CONTRACT CHANGE ORDER FACT SHEET**

Original Contract Value: \$1,781,000.00
Value of this Change Order: (\$95,367.16)
Cumulative Change Order Value, Including this Change Order: (\$95,367.16)
New Contract Value, including this Change Order: \$1,685,632.84
Contract Completion Date Prior to this Change Order: April 10, 2024
Time Extension, this Change Order: N/A
Total Change Order Contract Time Extension: N/A
Cumulative Change Order % of Original Contract: -5.35%



Kevin McGahey, Purchasing Agent Date 10/31/2023



Joshua Palombo, Program Manager Date 8/29/23

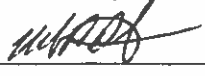

Robert P. Donato, Chief Financial Officer Date 8/31/2023

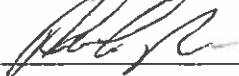

Thomas J. LaRocco, Chief Engineer Date 8/29/23



Joseph V. Rizzuto, Executive Director Date 08/24/23

CHANGE ORDER

Cape May County MUA Contract OC-18-22 Change Order No. 1

The CONTRACTOR is hereby directed to make the following changes in this contract.

1. SCOPE OF WORK:

The purpose of this change order is to decrease the contract amount by \$95,367.16, which is the sum of the reduction of Line Item 5 and Line Item 10, and an increase in Line Item 11, in the amounts of \$9,431.00, \$135,936.16 and \$50,000.00 respectfully, such that the Contract amount will decrease from \$1,781,000.00 to \$1,685,632.84.

2. REASON FOR THIS CHANGE ORDER:

Item 5: Provision and Installation of Contractor Supplied Suction Discharge, Manifold Piping, Fittings, Valves and Appurtenances

The 32nd Street Pumping station on August 10, 2022 started leaking at a 24"x24"x14" wye fitting in the discharge manifold, whereas the Authority Executive Director declared it as an emergency and the Authority Staff contracted with Municipal Maintenance Company to perform the repair under and emergency contract. The fitting that failed was not a stock shelf fitting and was a long lead item. The contractor installed a temporary spool piece and ordered the fitting to be installed at a later time by others. The fitting was not delivered prior to this contact being bid. During the shop drawing review process, we were made aware that the fitting was delivered. The Authority contacted the contractor and offered it for use. The contractor submitted a credit quote of \$9,431.00 to use this fitting, which was found to fair and reasonable. This reduced this line item from \$500,00.00 to \$490,569.00.

Item 10: By-Pass Pumping

The Contractor submitted a bypass plan for review and approval as required by the bid specifications. During the review it was observed that several requirements were modified. The specification however, do allow for deviation from the specifications subject to approval by the Authority. More specifically the bypass system was to be manned during it operation, and the contractor was required to supply whatever source of power was required to operate the bypass pumps, whether diesel or electrically operated. The submitted plan requested use of the power from the pump station and a telemetry system in leu of manning the system 24 hours, 7 days a week. The Authority Staff had no real exception to the submittal and requested credits for the reduced scope. The contractor offered \$135,936.16 credit eliminating the bypass watch personnel, and for the diesel fuel they would have used during the bypass operations which was found to be fair and reasonable. This reduced this line item from \$810,000.00 to \$674,063.84

Item 11: Contingency Allowance for unforeseen Conditions (if and where directed) \$100,000

It was expected that miscellaneous conditions would be discovered that would require immediate attention once the various existing piping and mechanical appurtenances were dismantled while the station was shut down. As a result, this pay item was established such that the necessary work could be done on an "if and Where Directed" basis while the station was on bypass so as to avoid delays and safety concerns. To date at \$45,339.00 of the original \$100,000.00 allowance amount has been dedicated and or encumbered to resolve unforeseen problems that have been encountered during the contractor's required piping verification inspection prior to construction. Since the construction phase has not yet started, it is recommended that the amount of this pay item be increased by \$50,000.00 This increases this line item from \$ 100,000.00 to \$150,000.00.

3. REFERENCES:

Refer:

Attachment A - Item 5, Attachment B- Item 10, Attachment C - Item 11

4. CONTRACT AMOUNT:

Contract Amount Prior to this Change Order:	<u>\$1,781,000.00</u>
(Increase) <u>(Decrease)</u> Lump Sum Dollars:	<u>\$ -95,367.16</u>
New Contract Amount Including this Change Order.	<u>\$1,685,632.84</u>

5. CONTRACT TIME:

Contract Completion Date Prior to this Change Order:	<u>April 10, 2024</u>
(Increase) (Decrease) Calendar Days:	<u>N/A</u>
New Contract Completion Date Including this Change Order:	<u>April 10, 2024</u>

This change order constitutes full mutual accord and satisfaction for all costs related directly or indirectly to this change. By acceptance of this change order, the Contractor hereby acknowledges and agrees that the change order represents the total equitable adjustment owed under the Contract, and further agrees to waive all right, without reservation or exception, to file any further claim or request for change arising out of or as a result of this change order or the cumulative impact of changes on the Contract. Except as hereby modified, all terms and conditions of the contract remain unchanged and in full force and effect.

CONTRACTOR/ ADDRESS:

Allied Construction Group, Inc
499 Washington Road
Parlin, N.J. 08859

OWNER/ADDRESS:

Cape May County MUA
1523 Route 9 North
Cape May Court House, NJ 08210

RECOMMENDED:

Cape May County MUA
1523 Route 9 North
Cape May Court House, N.J. 08210

BY: _____
DATE: _____

BY: _____
DATE: _____

BY: _____
DATE: _____

ENGINEER'S ESTIMATE		OPENING DATE	
\$2,300,000.00		Tuesday November 1, 2022 @ 2:00 P.M.	
CONTRACT NUMBER AND TITLE			
OC-18-22 Ocean City Region 32nd Street Pump Station Piping and Pump Upgrades			
ITEM	DESCRIPTION	QUANTITY	
1	Mobilization not to exceed 3% of the total construction cost, including mobilization	1	
2	Removal and Disposal of existing pumps, drive shafts, motors and Appurtenances	1	
3	Installation of Owner Supplied Pumps, Motors and Appurtenances	1	
4	Removal and Disposal of Existing Manifold Piping, Valves, Fittings and Appurtenances	1	
5	Provision and Installation of Contractor Supplied Suction Discharge, Manifold Piping, Fittings, Valves and Appurtenances	1	
6	Installation of Owner Supplied Suction- Discharge, Manifold Piping, Fittings, Valves and Appurtenances	1	
7	Provision and Installation of Miscellaneous Piping, All Pipe Supports, Hangers and Appurtenances	1	
8	Painting, including surface preparation	1	
9	Replacement of Mechanical Joint Wall Piping Threaded Studs and Appurtenances	5	
10	By-Pass Pumping	1	
11	Contingency Allowance for unforeseen Conditions (if and where directed) \$100,000	1	
TOTAL AMOUNT BID			
		\$	1,781,000.00
		\$	(95,367.16)
			1,685,632.84

Allied Construction Group, Inc.		Change Order Amount		Balance of Contract	
UNIT PRICE	EXT. PRICE	UNIT PRICE	EXT. PRICE	UNIT PRICE	EXT. PRICE
	30,000.00				30,000.00
	10,000.00				10,000.00
	35,000.00				35,000.00
	156,000.00				156,000.00
	500,000.00		-9,431.00		490,569.00
	60,000.00				60,000.00
	30,000.00				30,000.00
	40,000.00				40,000.00
	10,000.00				10,000.00
	810,000.00		-135,936.16		674,063.84
	100,000.00		50,000.00		150,000.00

Attachment A



George Hann <hanng@cmcmua.com>

Re: OC-18-22 Ocean City 32nd Street Piping and Pump Upgrades

George Hann <hanng@cmcmua.com>

To: Matthew Marcinczyk <mmarcinczyk@alliedconstructgroup.com>

Cc: Tom LaRocco <laroccoj@cmcmua.com>, Christopher Deane <cdeane@alliedconstructgroup.com>, Dean Madden <dmadden@alliedconstructgroup.com>, Amanda Mueller <allied@alliedconstructgroup.com>, Liliana Sargent <admin@alliedconstructgroup.com>

Mon, Apr 3, 2023 at 10:45 AM

Matthew,

Yes, let's proceed with using our Wye, as to the credit we are going to execute as a change order

This change order will go against - Item 5 "Provision and Installation of Contractor Supplied Suction Discharge, Manifold Piping, Fittings, Valves and Appurtenances" as a reduction in the amount of your offering of \$9,431.00 New amount would be \$490,569.00

Have you had the chance to review and consider our comments on the Bypass System

On Mon, Apr 3, 2023 at 10:15 AM Matthew Marcinczyk <mmarcinczyk@alliedconstructgroup.com> wrote:

Good morning George – sorry to bother you but I was wondering if you decided on the e-mail below yet? We have released all the DI pipe/fittings for mfg and I want to let the vendor know if we need to cancel one of the 24" x 24" x 14" Flanged DI Lateral Wyes. Thanks very much!

Matthew Marcinczyk, P.E.

Allied Construction Group, Inc.

499 Washington Road

Parlin, NJ 08859

P (732) 257-0772

F (732) 257-0774

STATEMENT OF CONFIDENTIALITY: The information contained in this transmission including any attached documentation is privileged and confidential. It is intended only for the use of the individual or entity named above. If the reader of this message is not the intended recipient, you are hereby notified that any dissemination, distribution or copy of this communication is strictly prohibited. If you have received this communication in error, please notify Allied Construction Group, Inc. immediately by replying to this email. Please delete all copies of this message and any attachments immediately.

From: Matthew Marcinczyk
Sent: Thursday, March 30, 2023 10:29 PM
To: George Hann <hanng@cmcmua.com>; Tom LaRocco <laroccotj@cmcmua.com>
Cc: Christopher Deane <cdeane@alliedconstructgroup.com>; Dean Madden <dmadden@alliedconstructgroup.com>; Amanda Mueller <allied@alliedconstructgroup.com>; Liliana Surgent <admin@alliedconstructgroup.com>
Subject: RE: OC-18-22 Ocean City 32nd Street Piping and Pump Upgrades
Importance: High

George – we appreciate you reaching out to us about the DI fitting. Our cost for Qty. (1) Proteco 401 lined 24" x 24" x 14" Flanged DI Lateral Wye is **\$9,431**. If the Authority accepts this as a credit amount, we will gladly use the fitting.

Please let us know and we can write this up formally.

Regards,

Matthew Marcinczyk, P.E.

Allied Construction Group, Inc.

499 Washington Road

Parlin, NJ 08859

P (732) 257-0772

F (732) 257-0774

STATEMENT OF CONFIDENTIALITY: The information contained in this transmission including any attached documentation is privileged and confidential. It is intended only for the use of the individual or entity named above. If the reader of this message is not the intended recipient, you are hereby notified that any dissemination, distribution or copy of this communication is strictly prohibited. If you have received this communication in error, please notify Allied Construction Group, Inc. immediately by replying to this email. Please delete all copies of this message and any attachments immediately.

From: George Hann <hanng@cmcmua.com>
Sent: Thursday, March 30, 2023 9:18 AM
To: Matthew Marcinczyk <mmarcinczyk@alliedconstructgroup.com>; Tom LaRocco <larocco@cmcmua.com>
Subject: OC-18-22 Ocean City 32nd Street Piping and Pump Upgrades

Matthew,

Just wanted to make you aware that we now have a 24" x 24" by 14" wye that was going to replace the one that leaked on pump 1. This leak and the condition of the existing wye that leaked is what made us decide to replace the entire manifold system.

We would offer you this fitting for a fair and reasonable credit should you decide to utilize it. We know you do not have to and that's fine too.

--
Cape May County Municipal Utilities Authority

Respectfully

George E. Hann, Jr., PE
Senior Project Engineer

1523 Route 9 North, Cape May Court House, NJ 08210
P:609.465.9026 x1227 – F:609.465.9025

hanng@cmcmua.com

--
Cape May County Municipal Utilities Authority

Respectfully

George E. Hann, Jr., PE

Senior Project Engineer

1523 Route 9 North, Cape May Court House, NJ 08210
P:609.465.9026 x1227 – F:609.465.9025

hanng@cmcmua.com

Attachment B



499 Washington Road, Parlin, NJ 08859
tel 732.257.0772 fax 732.257.0774
www.ALLIEDCONSTRUCTGROUP.COM

PROJECT: 325 - CMCMUA
Ocean City Region 32nd Street Pump Station
Piping & Pump Upgrades

TITLE: Bypass Pumping System

TO: Cape May County Municipal Utilites Authority
1523 Route 9 North
Cape May Court House, NJ 08210

ATTN: Thomas J. LaRocco, P.E.

SUBMITTAL

NO. 015400-01A

DATE: 08/07/2023

JOB: 325

DIVISION: 01

TRADE: General Requirements

SECTION: 015400

RE-SUBMITTAL:

<input checked="" type="checkbox"/> Shop Drawings <input type="checkbox"/> Letter <input type="checkbox"/> Prints <input type="checkbox"/> Plans	<input type="checkbox"/> Samples <input type="checkbox"/> Specifications <input type="checkbox"/> Other: <input type="checkbox"/> Other:
---	---

<u>COPIES</u>	<u>SECTION</u>	<u>DATE</u>	<u>DESCRIPTION</u>
1	015400	08/07/23	Bypass Pumping System

REMARKS:

APPROVED FOR CONTRACT REQUIREMENTS

The Contractor's signature below indicates that he/she has checked the shop drawing with the Contract Drawings and Specifications and found it to meet the requirements of the same including dimensions, and that the Contractor's guarantee fully complies to the specified material or equipment.

Signed by: Matthew Marcinczyk, P.E.

Submittal 015400-01A Bypass Pumping System Re-Submittal

1. Section 1.02. B. 2.:

Comment: This paragraph calls for the system to be manned 24 hours a day. The plan doesn't conform to this requirement. The Plan proposes an alarm auto dialer system, for which the Contractor shall be responsible for responding to the alarm. The Authority will consider the use of the alarm dialer system, however, since the proposal doesn't man the system 24 hours a day, the Authority expects to receive some form of compensation.

Response: The Contractor is proposing a credit to the contract in the amount of \$122,496.16 for not providing 24-hour per day manning of the bypass pump system. See the attached credit calculation.

2. Section 1.04. F.:

Comment: This paragraph requires the bypass flows to be metered with a totalizer. The plan doesn't conform to this requirement. The plans should be modified to include some form of method to monitor and record the daily flows pumped from the bypass system.

Response: The Bypass Pumping Contractor proposes to utilize the flow meter on the force main located at the wastewater treatment plant. This will allow the air relief located on the bypass connection to purge all the air from the Godwin bypass pumps during the constant repriming and will allow for consistent flow readings.

3. Section 1.05. F.:

Comment: This paragraph calls for the pump station influent gravity lines to be plugged, stopping all flow from entering the station. The plan suggests that the wet well will be flooded during the bypass duration. This may work during certain stages of the work, but will not, during the replacement-repairs to the suction wall sleeves. Please modify the plan to include your proposed method of bypassing this stage of the project.

Response: The Bypass plan states that we will be plugging the influent pipes to the station. See Item 7 of the System Installation on Page 2. On Page 1 of the System Detail, we are recommending flooding the wet well only after the suction valves are secure.

4. Section 1.08. F.

Comment: This paragraph requires the Contractor to prepare a Traffic Control Plan that must be submitted to and approved by the Ocean City Police Department as it relates to the staging of the bypass system. This Traffic Control Plan shall be made part of this submittal.

Response: The traffic plan used will be the same plan that the Bypass Pumping Contractor has used for past projects at this pump station, and it will be approved by the Ocean City Police Dept prior to going on bypass. We will provide an e-mail approval from the City once we receive it.

5. Section 2.01 Bypass Pump System Description, Performance, and design Requirements. K.:

Comment: This paragraph allows for the use of an electric powered pumping system and requires the Contractor to supply the necessary 3 phase or medium voltage service as required to power the pumps. The plan has requested to utilize power from the station, which, in turn, would require

the Authority to pay for the power required to run the electric powered system. The Authority will consider this proposal, but the Authority would require some form of compensation for its use.

Response: The Contractor is proposing a credit to the contract in the amount of \$13,440 for the fuel required to operate a diesel bypass pumping system. See the attached credit calculation.

**Cape May County MUA
Contract OC-18-22
32nd Street Pump Station Piping & Pump Replacement**

Bypass Pumping Fuel Credit

Diesel Pump System Fuel Usage:	60 GPD
Bypass Pump Duration:	8 Weeks
Fuel Price:	\$ 4.00 Per Gallon
Fuel Required (60 GPD x 7 Days/Week x 8 Weeks):	3360 Gallons
Fuel Cost Credit:	\$ 13,440.00

Pump Watch Credit:

Bypass Pump Duration:	8 Weeks	
Pump Watch Reg. Rate:	\$ 94.64 Per Hour	(Monday to Friday 7:00 to 3:30 PM)
Pump Watch OT 1.5 Rate:	\$ 123.83 Per Hour	(Monday to Friday 3:30 PM to 6:00 AM and Saturdays)
Pump Watch OT 2.0 Rate:	\$ 153.00 Per Hour	(Sundays)

Calculation:

Hours Per Week That Pump Watch is Needed*:				
Monday-Friday (70) Hours Per Week x 8 Weeks:	560 Hours	@	\$ 123.83 Per Hr	\$ 69,344.80
Saturday (24) Hours Per Week x 8 Weeks:	192 Hours	@	\$ 123.83 Per Hr	\$ 23,775.36
Sunday (24) Hours Per Week x 8 weeks:	192 Hours	@	\$ 153.00 Per Hr	\$ 29,376.00
Pump Watch Credit:				\$ 122,496.16

*Note: Job Foreman Will Be On-Site 10 Hrs Per Day (Mon-Fri)

Attachment C

ALLIED

CONSTRUCTION GROUP INC

499 Washington Road, Parlin, NJ 08859
 tel 732.257.0772 fax 732.257.0774
 www.ALLIEDCONSTRUCTGROUP.COM

TITLE:	Contingency Item 11.1 Additional Pipe Replacement	PROPOSAL
PROJECT:	325 - CMCMUA Ocean City Region 32nd Street Pump Station Piping & Pump Upgrades	NO. 11.1
TO:	Attn: George Hann, P.E. Cape May County Municipal Utilities Authority 1523 Route 9 North Cape May Court House, NJ 08210	DATE: 06/21/2023 JOB: 325 CONTRACT/PO: OC-18-22
		SUBMITTED: 06/21/2023 COMPLETED: REQUIRED: 06/26/2023

DESCRIPTION

In accordance with your request and in conjunction with the response to RFI-01, we are submitting pricing for the following items:

Item 1. Cost to remove and replace existing deteriorated ductile iron pipe spools (Mark #'s E-23; E-65A; E-65B; E-66A; E-66B; and E-71) that were to be re-used. Additional bypass pumping time is not required for this work

Item #1A. Cost to remove and replace the following additional ductile iron fittings (Mark #'s E-11; E-33; E-48; E-54; and E-56) with new lined fittings which will provide for the replacement of all immediate pump suction and discharge piping below the main discharge header. Additional bypass pumping time is not required for this work

Item #1B. Cost to remove and replace the balance of the remaining ductile iron pipe; fittings; and couplings (not required to be replaced in the original contract or in Item #1 or Item #1A above). Additional bypass pumping time is required for this work but no charge.

Num	Item	Description	Ref	Qty	Unit	Unit Price	Amount
1	1	See Above		1,000	LS	14,276.00	14,276.00
2	1A	See Above		1,000	LS	17,060.00	17,060.00
3	1B	See Above		1,000	LS	131,518.00	131,518.00
						Total:	\$162,854.00

ACCEPTED

Matthew
 Marcinczyk

Digitally signed by Matthew Marcinczyk
 DN: cn=Matthew Marcinczyk, c=US, o=Allied
 Construction Group, Inc,
 email=mmarcinczyk@alliedconstructgroup.com
 Date: 2023.06.21 16:24:15 -0400

By: _____
 Matthew Marcinczyk, P.E.

Date: 06/21/2023 _____

By: _____

Date: _____

ALLIED CONSTRUCTION GROUP, INC

499 Washington Road

Parlin, NJ 08859

Cape May County Utilities Authority

Contract OC-18-22

32nd Street Pumping Station Piping & Pumps Upgrades

PCO-01 Piping Replacments

DESCRIPTION	Qty.	Unit	Rate	Total
Payroll Costs - Paragraph 11.4.1				
Project Manager	0	Hrs	\$ 175.00	\$ -
Plumber Foreman	0	Hrs	\$ 130.06	\$ -
Plumber	0	Hrs	\$ 120.03	\$ -
Subtotal:				\$ -
Materials & Equipment - Paragraph 11.4.2				
Raritan Supply - DI Piping	1	LS	\$ 11,671.44	\$ 11,671.44
Subtotal:				\$ 11,671.44
Total:				\$ 11,671.44
Contractor's Fee on Payroll, Materials & Equipment Costs Per Paragraph 11.6.1				
Contractor's Fee (20%)				\$ 2,334.29
Total:				\$ 14,005.73
Subcontractors Costs - Paragraph 11.4.3				
Subtotal:				\$ -
Contractor's Fee on Subcontractors Paragraph 11.6.2				
Contractor's Fee on Subcontractors (10%):				\$ -
Total:				\$ -
Supplemental Costs -Paragraph 11.4.5				
Consultant - Outside Engineering	2	Hr	\$ 70.00	\$ 140.00
Consultant - Pipe & Equipment Detailer	2	Hr	\$ 65.00	\$ 130.00
Consultant - CPM Schedule (Add/Update)	0.25%	LS	\$ -	\$ -
Consultant - Safety	0.25%	LS	\$ -	\$ -
Subtotal:				\$ 270.00
Total for Bond & Insurance Amounts:				\$ 14,275.73
Insurance Cost - Not Allowable				
11.01-A-5-I - Insurance - Pollution Liability Policy	0.10%	X	\$ -	\$ -
11.01-A-5-I - Insurance - Umbrella Policy (Cost of Subs)	0.13%	X	\$ -	\$ -
11.01-A-5-I - Insurance - G.L. Policy (Cost of Subs)	0.51%	X	\$ -	\$ -
Total:				\$ 14,275.73
Bond Cost - Not Allowable				
Bond Premium (1.6% for total amount less than \$500,000)				\$ -
Grand Total:				\$ 14,275.73

Say Total: \$ 14,276

Estimate Description / Task: PCO # 1 Replacement of Existing piping to be reused vs buy new and install Estimate

Item No.	Work / Task Description	Labor Hr's	Quantity	Const. Equip. Rentals		Const. Equip. FOG		Services, Tools & Supplies		Permanent Materials		Labor Costs		Subcontract Total	TOTAL AMOUNT
				UP	Total	UP	Total	UP	Total	UP	Total	UP	Total		
PCO # 1	Is to replace existing DI Pipes that are required to be reused and in Allied's opinion are in bad shape exteriors for reuse, and / or are currently connected to the MJ Wall Ftg joints and most likely deteriorated ends that may cause leakage / failures upon reinstallations.														\$ -
	Per Allied's approved piping layout Dwg's and listings of Existing Owner's current installed pipes and fittings we are to reuse as follows are the minimum Allied suggested items Owner should consider replacing with new materials:														\$ -
Quote	Raritan Supply for replacement DI items below:		LS												\$ -
-23	New = 2 pc's 12" x 1'-9 1/4" ea. +F, F x PE		2												\$ -
-65A	New = 1 pc's 16" x 2'-4" PE x PE		1												\$ -
-65B	New = 1 pc's 16" x 4'-3 1/2" F x PE		1												\$ -
-66A	New = 1 pc's 16" x 4'-3 1/2" PE x PE		1												\$ -
-66B	New = 1 pc's 16" x 4'-3 1/2" F x PE		1												\$ -
-71	New item to replace 16" MJ Glands vs using existing corroded / rusted Glands at the Wet Well Wall Ftg's		4												\$ -
labor	Some savings of MH's by not having to field cut some pieces to shorten in the field for Existing Pc's # E23, E65A/B & 66A/B Say 2 Pib's at 1 Hr's per cut x 3 cuts =														\$ -
labor	Some added MH's by having to hoist up old pieces not reusing and disposals plus having to off load new pieces into Bldg and lowering down to Pump room for installations Say 2 Pib's @ 3 Hr's	-6													\$ -
Sub	Field Painting = No added Costs	0													\$ -
total Mat's / Labor Hr's Cost PCO -1	0.0								\$ 11,672				\$ -	\$ 11,672

ALLIED CONSTRUCTION GROUP, INC

499 Washington Road

Parlin, NJ 08859

Cape May County Utilities Authority

Contract OC-18-22

32nd Street Pumping Station Piping & Pumps Upgrades

PCO-01A Piping Replacements

DESCRIPTION	Qty.	Unit	Rate	Total
Payroll Costs - Paragraph 11.4.1				
Project Manager	0	Hrs	\$ 175.00	\$ -
Subtotal:				\$ -
Materials & Equipment - Paragraph 11.4.2				
Raritan Supply - DI Fittings & Pipe Spools	1	LS	\$ 13,992.00	\$ 13,992.00
Subtotal:				\$ 13,992.00
Total:				\$ 13,992.00
Contractor's Fee on Payroll, Materials & Equipment Costs Per Paragraph 11.6.1				
Contractor's Fee (20%)				\$ 2,798.40
Total:				\$ 16,790.40
Subcontractors Costs - Paragraph 11.4.3				
Subtotal:				\$ -
Contractor's Fee on Subcontractors Paragraph 11.6.2				
Contractor's Fee on Subcontractors (10%):				\$ -
Total:				\$ -
Supplemental Costs -Paragraph 11.4.5				
Consultant - Outside Engineering	2	Hr	\$ 70.00	\$ 140.00
Consultant - Pipe & Equipment Detailer	2	Hr	\$ 65.00	\$ 130.00
Consultant - CPM Schedule (Add/Update)	0.25%	LS	\$ -	\$ -
Consultant - Safety	0.25%	LS	\$ -	\$ -
Subtotal:				\$ 270.00
Total for Bond & Insurance Amounts:				\$ 17,060.40
Insurance Cost - Not Allowable				
11.01-A-5-I - Insurance - Pollution Liability Policy	0.10%	X	\$ -	\$ -
11.01-A-5-I - Insurance - Umbrella Policy (Cost of Subs)	0.13%	X	\$ -	\$ -
11.01-A-5-I - Insurance - G.L. Policy (Cost of Subs)	0.51%	X	\$ -	\$ -
Total:				\$ 17,060.40
Bond Cost - Not Allowable				
Bond Premium (1.6% for total amount less than \$500,000)				\$ -
Grand Total:				\$ 17,060.40

Say Total: \$ 17,060

ALLIED CONSTRUCTION GROUP, INC

499 Washington Road

Parlin, NJ 08859

Cape May County Utilities Authority

Contract OC-18-22

32nd Street Pumping Station Piping & Pumps Upgrades

PCO-01B Piping Replacments

DESCRIPTION	Qty.	Unit	Rate	Total
Payroll Costs - Paragraph 11.4.1				
Project Manager	0	Hrs	\$ 175.00	\$ -
Plumber Foreman	103	Hrs	\$ 130.06	\$ 13,396.18
Plumber	205	Hrs	\$ 120.03	\$ 24,606.15
Subtotal:				\$ 38,002.33
Materials & Equipment - Paragraph 11.4.2				
Raritan Supply - DI Fittings & Pipe Spools	1	LS	\$ 67,379.71	\$ 67,379.71
Misc. Materials	1	LS	\$ 3,650.00	\$ 3,650.00
Subtotal:			\$ 71,029.71	\$ 71,029.71
Total:				\$ 109,032.04
Contractor's Fee on Payroll, Materials & Equipment Costs Per Paragraph 11.6.1				
Contractor's Fee (20%)				\$ 21,806.41
Total:				\$ 130,838.45
Subcontractors Costs - Paragraph 11.4.3				
Bypass Pumping (Required But No Charge)	2	Wk	\$ -	\$ -
Subtotal:				\$ -
Contractor's Fee on Subcontractors Paragraph 11.6.2				
Contractor's Fee on Subcontractors (10%):				\$ -
Total:				\$ -
Supplemental Costs -Paragraph 11.4.5				
Consultant - Outside Engineering	6	Hr	\$ 70.00	\$ 420.00
Consultant - Pipe & Equipment Detailer	4	Hr	\$ 65.00	\$ 260.00
Consultant - CPM Schedule (Add/Update)	0.25%	LS	\$ -	\$ -
Consultant - Safety	0.25%	LS	\$ -	\$ -
Subtotal:				\$ 680.00
Total for Bond & Insurance Amounts:				\$ 131,518.45
Insurance Cost - Not Allowable				
11.01-A-5-I - Insurance - Pollution Liability Policy	0.10%	X	\$ -	\$ -
11.01-A-5-I - Insurance - Umbrella Policy (Cost of Subs)	0.13%	X	\$ -	\$ -
11.01-A-5-I - Insurance - G.L. Policy (Cost of Subs)	0.51%	X	\$ -	\$ -
Total:				\$ 131,518.45
Bond Cost - Not Allowable				
Bond Premium (1.6% for total amount less than \$500,000)				\$ -
Grand Total:				\$ 131,518.45

Say Total: \$ 131,518

Project Name: Allied # 325 CMCMUA PCO # 1B

Date: 4/19/2023

Project Location: Ocean City, N.J.

By: JL

Piping System: Removal / Replace (Remaining Balance) existing piping system "NOT" included PCO - 1 & PCO # 1A

Page: 1 of 2

(REMOVAL "EXISTING")

Dwg's Ref:

Item No.	Description	Size	Quantities	Materials Costs		Labor MH's	
				U.P.	Total	Unit MH	Total MH's
1.	PCO-1B, E-1 4B. 90°	24"	3			6.0	18.0
2.	PCO-1B, E-2 4VB" + HK. FILLER	24"	1			5.0	5.0
3.	PCO-1B, E-3 FLG. TEE w/ 2" NPT. TAP. @ R.	24"	1			5.0	5.0
4.	PCO-1B, E-4 HEG x HEG SPOOL 1'-6"	24"	1			6.0	6.0
5.	PCO-1B, E-7 HEG. COND. ROD	24" x 12"	1			5.0	5.0
6.	PCO-1B, E-19 L I I	24" x 14"	1			5.0	5.0
7.	PCO-1B, E-26 S.B. #411 COUP.	24"	1			5.0	5.0
8.	PCO-1B, E-67 HEG x PESPOOL 1'-4 3/8"	24"	1			6.0	6.0
9.	PCO-1B, E-68 HEG. x HEG 1'-5 7/8"	24"	1			6.0	6.0
10.	PCO-1B, E-70 HEG. x PE 1'-2"	24"	1			6.0	6.0
11.	PCO-1B, E-72 MECA LUG KIT (M/T GLAND, GASKET, ETC)	24"	1			1.0	1.0
12.	PCO-1B, E-73 HEG Jt GASKET SBR W/ NUTS	24"	5			6.0	30.0
13.	PCO-1B, E-74 M/T GASKET w/ 3/4" x 3/2" SS 304 STUDS w/ 304 SS. NUTS	24"	1			7.0	7.0
14.	ADD TIME M/T W/ M/ HEG. CLEAN-UP, RESTRAPPING BOLT HOLES	24"	1	LS.	1.00.	4.0	4.0
15.	ADD TIME HOISTING OUT BLDG TO SCRAP DUMPSTER & DISPOSAL					5x8	40.0
16.	SCRAP DUMPSTER HAUL CHARGES SNY 2 @ \$400.			LS	800.		
17.	ADDED "SAFETY" HOIST POINTS w/ PULLIES, LOAD, CHAIN BLOCKS, "AND" USE TO INSTALL "NEW" ALSO = ANCHORS, ETC.			LS	1,000.	3x8	24.0
19.	ADDED WASH DN'S, CLEAN UPS			LS.	200	2x8	16.0
TOTAL					\$1,900.		189

M/H'S

Project Name: Allied # 325 CCMUA PCO # 1B

Date: 4/19 / 2023

Project Location: Ocean City, N.J.

By: JIL

Piping System: Removal / Replace (Remaining Balance) existing piping system "NOT" included PCO - 1 & PCO # 1A

Page:

(NEW INSTALL)

Dwg's Ref:

2 of 2

Item No.	Description	Size	Quantities	Materials Costs		Labor MH's	
				U.P.	Total	Unit MH	Total MH's
1.	PCO-1B, E-1 FLG. 90°	24"	3			6.	18.
2.	PCO-1B, E-2 4 1/8" THK. FILLER	24"	1			5.	5.
3.	PCO-1B, E-3 FLG. TEE w/ 2" NPT. Tap. OK.	24"	1			5.	5.
4.	PCO-1B, E-4 FLG X FLG Spool 1'-6"	24"	1			6.	6.
5.	PCO-1B, E-7 FLG. Conn. Red	24" x 12"	1			5.	5.
6.	PCO-1B, E-19 L I I	24" x 14"	1			5.	5.
7.	PCO-1B, E-26 S.B. #411 Coup.	24"	1			5.	5.
8.	PCO-1B, E-67 FLG X PE Spool 1'-4 3/8"	24"	1			6.	6.
9.	PCO-1B, E-68 FLG. X FLG. S 1'-5 3/8"	24"	1			6.	6.
10.	PCO-1B, E-70 FLG. X PE S 1'-2"	24"	1			6.	6.
11.	PCO-1B, E-72 MECA LUG KIT (M.T.G. AND GASKET ETC)	24"	1			1.	1.
12.	PCO-1B, E-73 FLG. Jt GASKET SBR W/ NUTS	24"	5			6.	30.
13.	PCO-1B, E-74 M.T.G. GASKET w/ 3/4" x 3/2" SS 304 STUDS w/ 304 SS NUTS	24"	1			7.	7.
14.	" ADD ADDITIONAL FRT. 3/DEL!! (TO EXPEDITE DELIVERY?)	450.00	3		1,350.00		
15.	REINSTALL ORIGINAL HARNESS @ 24" COUP. USING NEW RODS, NUTS & OLD FLG. P.T'S	24"	1	SNY LS.	300.00	2x3 6	6.
16.	HDR. Existing Support REUSED PER CONTRACT. DIMS JUST READJUST AS NEEDED	"	2	SNY MISC	100.00	2x2 x2	8
TOTAL					69,130.		119

NA/AS

ESTIMATE SUMMARY

PCO-1B

Project: JOB 325 32ND ST PS CAPE MAY COUNTY MUA
 Location: _____
 Drawing No.: _____
 Spec. Sect.: ALLIED CONSTRUCTION GROUP

Estimator: PF
 Bid Date: _____
 Quote Date: 4/18/2023

LINE ITEM	SIZE	Description	Quantity	Unit	Group	Unit Price	Extended Price
NOTE: <i>IT IS THE CUSTOMER'S RESPONSIBILITY TO INFORM US OF ANY BUY AMERICA, BUY AMERICAN, PA STEEL ACT, AMERICAN IRON & STEEL (AIS), OR ANY OTHER DOMESTIC COMPLIANT PROJECTS. THESE PROJECTS REQUIRE SPECIAL PRICING AND WE MUST BE MADE AWARE OF THESE REQUIREMENTS PRIOR TO QUOTING THESE PROJECTS. DOMESTIC/AIS COMPLIANT MATERIALS CARRY A HIGHER PRICE AND CERTIFICATIONS MUST BE REQUESTED PRIOR TO SHIPPING MATERIAL AS THEY WILL NOT BE SUPPLIED AFTER MATERIAL HAS SHIPPED.</i>							
PCO-1B E-1	24"	90 BEND, FLANGED DUCTILE IRON C110 PROTECTO 401 IMPORT	3	EA	FLG	\$6,809.32	\$20,427.96
PCO-1B E-2	24"	4 1/8 THICK FILLER	1	EA	FLG	\$8,584.78	\$8,584.78
PCO-1B E-3	24" X 24"	TEE, FLANGED DUCTILE IRON C110 PROTECTO 401 IMPORT WITH 2"NPT TAP @ R	1	EA	FLG	\$9,668.63	\$9,668.63
PCO-1B E-4	24" X 1'-6"	FL X FL CLASS 53 DIP SPOOL PIECE PROTECTO 401 LINED	1	EA	FAB	\$3,596.50	\$3,596.50
PCO-1B E-7	24" X 12"	CONC. REDUCER, FLANGED D. I. C110 PROTECTO 401 IMPORT	1	EA	FLG	\$5,345.15	\$5,345.15
PCO-1B E-19	24" X 14"	CONC. REDUCER, FLANGED D. I. C110 PROTECTO 401 IMPORT	1	EA	FLG	\$5,060.63	\$5,060.63
PCO-1B E-26	24"	S/B 411 CPLG FOR DIP (25.8" OD) 7" LONG - 316 S/S HDWR	1	EA	HDW	\$1,665.53	\$1,665.53
PCO-1B E-67	24" X 1'-4 3/8"	FL X PE CLASS 53 DIP SPOOL PIECE PROTECTO 401 LINED	2	EA	FAB	\$2,338.00	\$4,676.00
PCO-1B E-68	24" X 1'-5 7/8"	FL X FL CLASS 53 DIP SPOOL PIECE PROTECTO 401 LINED	1	EA	FAB	\$3,596.50	\$3,596.50
PCO-1B E-70	24" X 1'-2"	FL X PE CLASS 53 DIP SPOOL PIECE PROTECTO 401 LINED	1	EA	FAB	\$2,338.00	\$2,338.00
PCO-1B E-72	24"	MEGALUG KIT - EBAA IRON	1	EA	YARD	\$648.92	\$648.92
PCO-1B E-73	24"	PLAIN NUT & BOLT KIT W/FLANGE-TYTE FF GASKET SBR	5	EA	HDW	\$331.73	\$1,658.65
PCO-1B E-74	24"	MJ GASKET WITH (16) 3/4" X 3-1/2 304SS STUD BOLT W/NUTS	1	EA	YARD	\$112.46	\$112.46
PCO-1B TOTAL							\$67,379.71

NOTES:

- 1) All dimensions and bearings on this drawing are to be as-shown, unless otherwise indicated. All dimensions are to be taken from the centerline of the shaft unless otherwise indicated. All dimensions are to be taken from the centerline of the shaft unless otherwise indicated.
- 2) The shafts are to be of the type specified in the notes. The shafts are to be of the type specified in the notes. The shafts are to be of the type specified in the notes.
- 3) The bearings are to be of the type specified in the notes. The bearings are to be of the type specified in the notes. The bearings are to be of the type specified in the notes.
- 4) The couplings are to be of the type specified in the notes. The couplings are to be of the type specified in the notes. The couplings are to be of the type specified in the notes.
- 5) The motor is to be of the type specified in the notes. The motor is to be of the type specified in the notes. The motor is to be of the type specified in the notes.
- 6) The pump is to be of the type specified in the notes. The pump is to be of the type specified in the notes. The pump is to be of the type specified in the notes.
- 7) The discharge pipe is to be of the type specified in the notes. The discharge pipe is to be of the type specified in the notes. The discharge pipe is to be of the type specified in the notes.
- 8) The suction pipe is to be of the type specified in the notes. The suction pipe is to be of the type specified in the notes. The suction pipe is to be of the type specified in the notes.
- 9) The foundation is to be of the type specified in the notes. The foundation is to be of the type specified in the notes. The foundation is to be of the type specified in the notes.

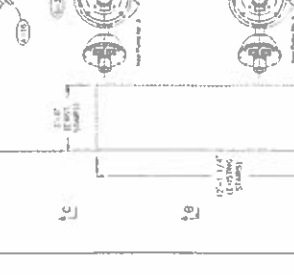
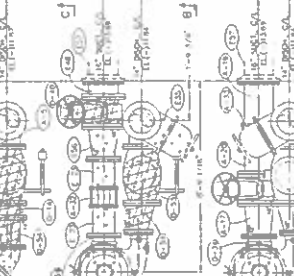
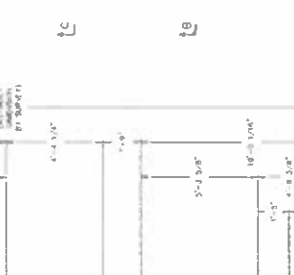
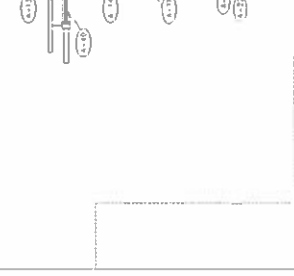
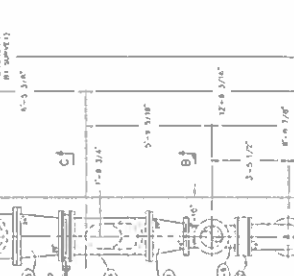
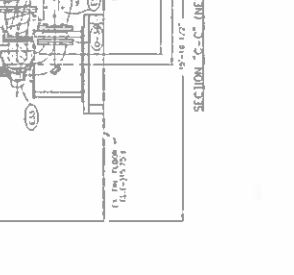
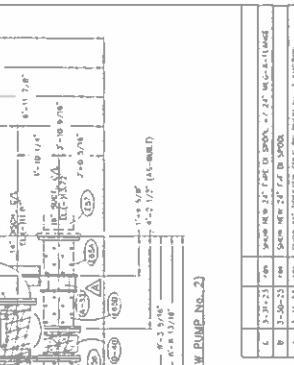
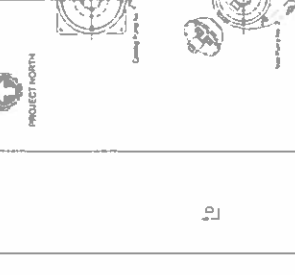
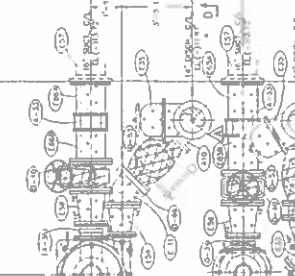
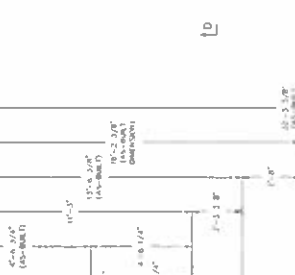
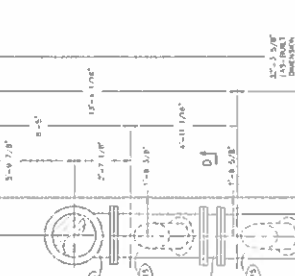
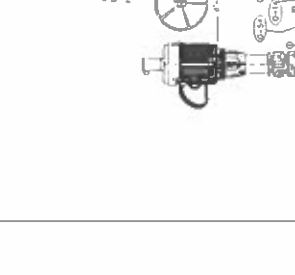
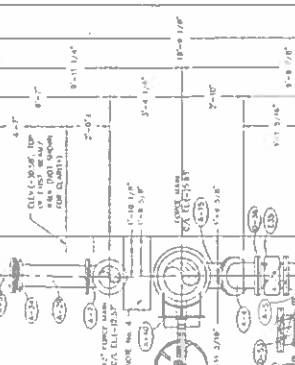
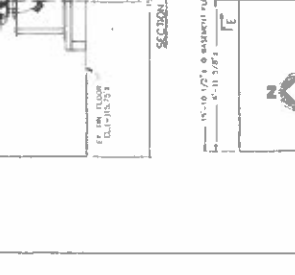
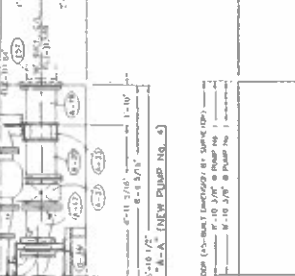
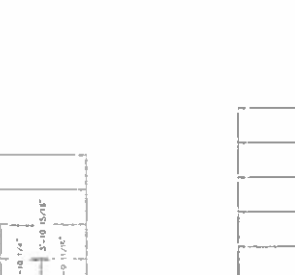
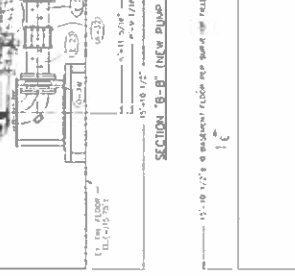
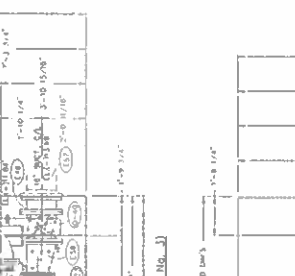
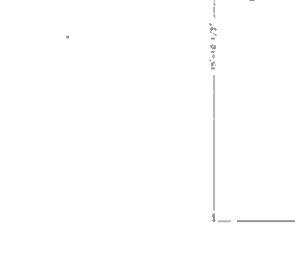
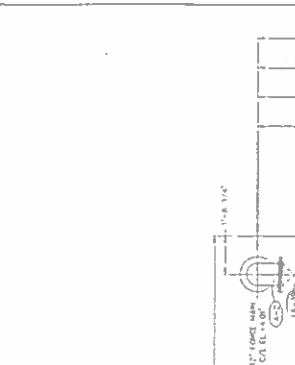
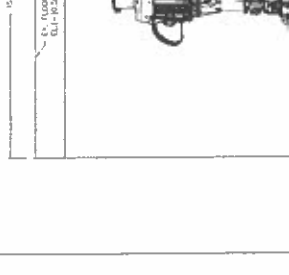
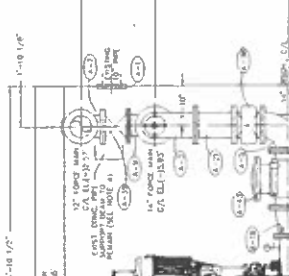
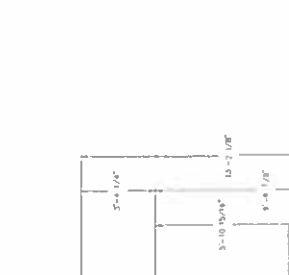
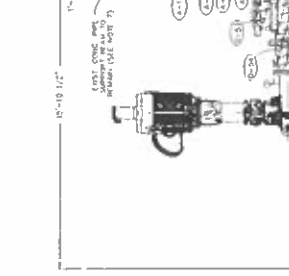
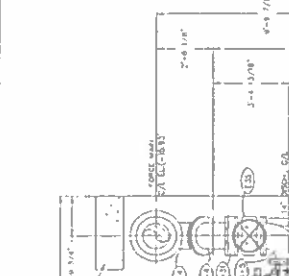
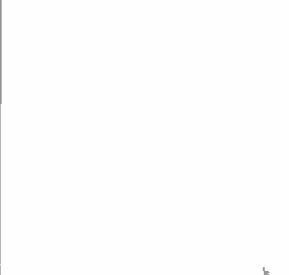

NO.	DATE	BY	DESCRIPTION
1	12-21-23	ME	ISSUE FOR CONSTRUCTION
2	12-21-23	ME	ISSUE FOR CONSTRUCTION
3	12-21-23	ME	ISSUE FOR CONSTRUCTION
4	12-21-23	ME	ISSUE FOR CONSTRUCTION

ALLIED CONSTRUCTION GROUP, INC.
 499 WASHINGTON ST., SUITE 200, NEWTON, MA 02459
 TEL: 617-552-1234 FAX: 617-552-1234
 WWW.ACGROUP.COM

UNIVERSITY PLAN VIEW - 14' - 24' NEW PUMP DISCHARGE FORCE MAIN BEARS @ ELEV. 15.53'
 15'-10 1/2" SECTION LINE

PLAN VIEW - NEW PUMP SUCTION/DISCHARGE PIPING ARRANGEMENT @ ELEV. 15.25'
 15'-10 1/2" SECTION LINE

UNIVERSITY PLAN VIEW - 14' - 24' NEW PUMP DISCHARGE FORCE MAIN BEARS @ ELEV. 15.53'
 15'-10 1/2" SECTION LINE

UNIVERSITY PLAN VIEW - 14' - 24' NEW PUMP DISCHARGE FORCE MAIN BEARS @ ELEV. 15.53'
 15'-10 1/2" SECTION LINE

UNIVERSITY PLAN VIEW - 14' - 24' NEW PUMP DISCHARGE FORCE MAIN BEARS @ ELEV. 15.53'
 15'-10 1/2" SECTION LINE

NOTES:

- 1) DIMENSIONS AND DIMENSIONS ON THIS DRAWING ARE THE AS-BUILT DIMENSIONS AND SHALL BE THE BASIS FOR THE AS-BUILT DIMENSIONS. THE DIMENSIONS SHOWN ON THIS DRAWING ARE THE DIMENSIONS OF THE PUMP AND MOTOR AS SUPPLIED BY THE MANUFACTURER. THE DIMENSIONS OF THE PUMP AND MOTOR SHALL BE THE BASIS FOR THE AS-BUILT DIMENSIONS. THE DIMENSIONS OF THE PUMP AND MOTOR SHALL BE THE BASIS FOR THE AS-BUILT DIMENSIONS.
- 2) THE DIMENSIONS OF THE PUMP AND MOTOR SHALL BE THE BASIS FOR THE AS-BUILT DIMENSIONS. THE DIMENSIONS OF THE PUMP AND MOTOR SHALL BE THE BASIS FOR THE AS-BUILT DIMENSIONS.
- 3) THE DIMENSIONS OF THE PUMP AND MOTOR SHALL BE THE BASIS FOR THE AS-BUILT DIMENSIONS. THE DIMENSIONS OF THE PUMP AND MOTOR SHALL BE THE BASIS FOR THE AS-BUILT DIMENSIONS.
- 4) THE DIMENSIONS OF THE PUMP AND MOTOR SHALL BE THE BASIS FOR THE AS-BUILT DIMENSIONS. THE DIMENSIONS OF THE PUMP AND MOTOR SHALL BE THE BASIS FOR THE AS-BUILT DIMENSIONS.
- 5) THE DIMENSIONS OF THE PUMP AND MOTOR SHALL BE THE BASIS FOR THE AS-BUILT DIMENSIONS. THE DIMENSIONS OF THE PUMP AND MOTOR SHALL BE THE BASIS FOR THE AS-BUILT DIMENSIONS.
- 6) THE DIMENSIONS OF THE PUMP AND MOTOR SHALL BE THE BASIS FOR THE AS-BUILT DIMENSIONS. THE DIMENSIONS OF THE PUMP AND MOTOR SHALL BE THE BASIS FOR THE AS-BUILT DIMENSIONS.
- 7) THE DIMENSIONS OF THE PUMP AND MOTOR SHALL BE THE BASIS FOR THE AS-BUILT DIMENSIONS. THE DIMENSIONS OF THE PUMP AND MOTOR SHALL BE THE BASIS FOR THE AS-BUILT DIMENSIONS.
- 8) THE DIMENSIONS OF THE PUMP AND MOTOR SHALL BE THE BASIS FOR THE AS-BUILT DIMENSIONS. THE DIMENSIONS OF THE PUMP AND MOTOR SHALL BE THE BASIS FOR THE AS-BUILT DIMENSIONS.
- 9) THE DIMENSIONS OF THE PUMP AND MOTOR SHALL BE THE BASIS FOR THE AS-BUILT DIMENSIONS. THE DIMENSIONS OF THE PUMP AND MOTOR SHALL BE THE BASIS FOR THE AS-BUILT DIMENSIONS.
- 10) THE DIMENSIONS OF THE PUMP AND MOTOR SHALL BE THE BASIS FOR THE AS-BUILT DIMENSIONS. THE DIMENSIONS OF THE PUMP AND MOTOR SHALL BE THE BASIS FOR THE AS-BUILT DIMENSIONS.

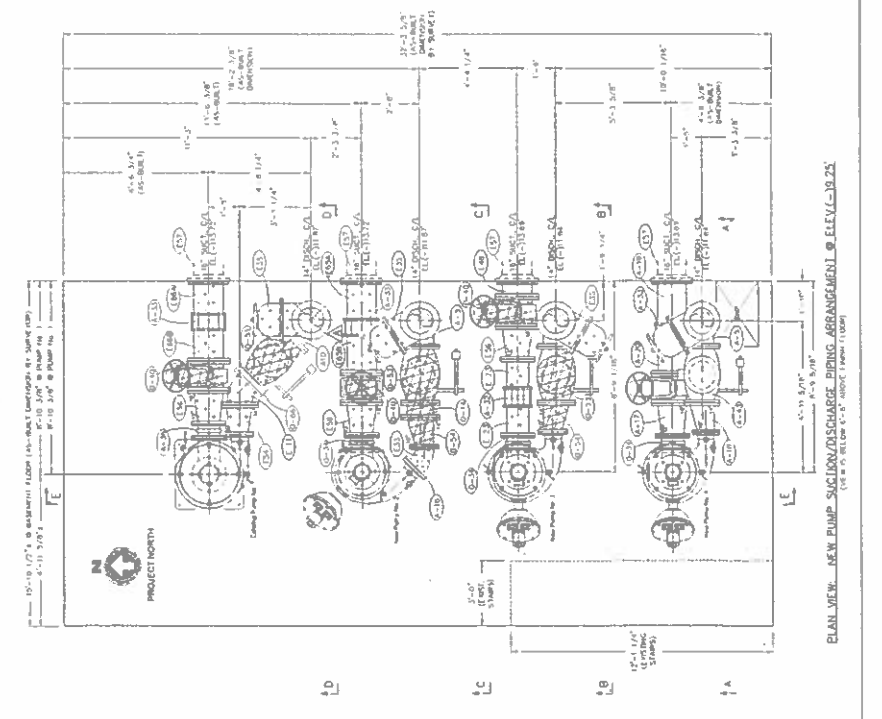
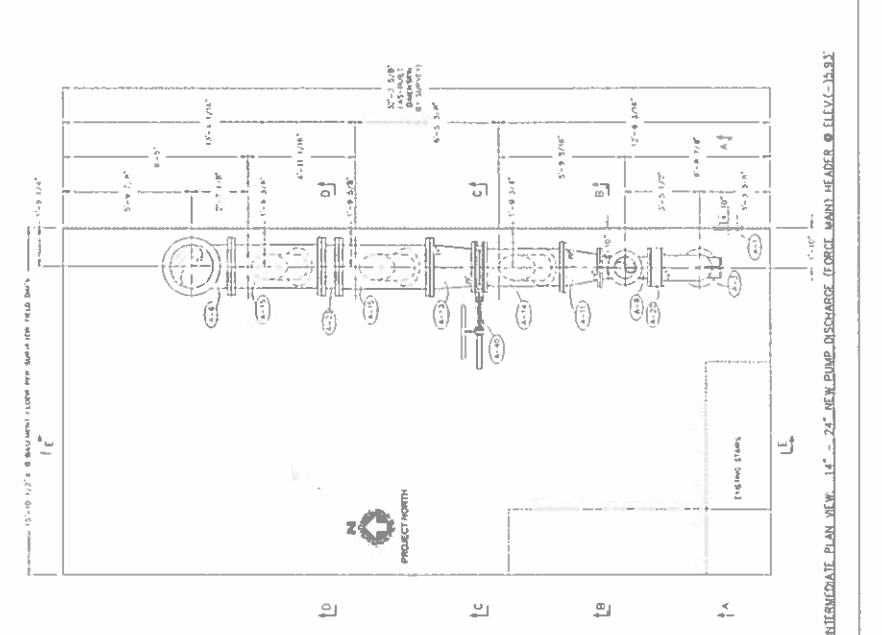
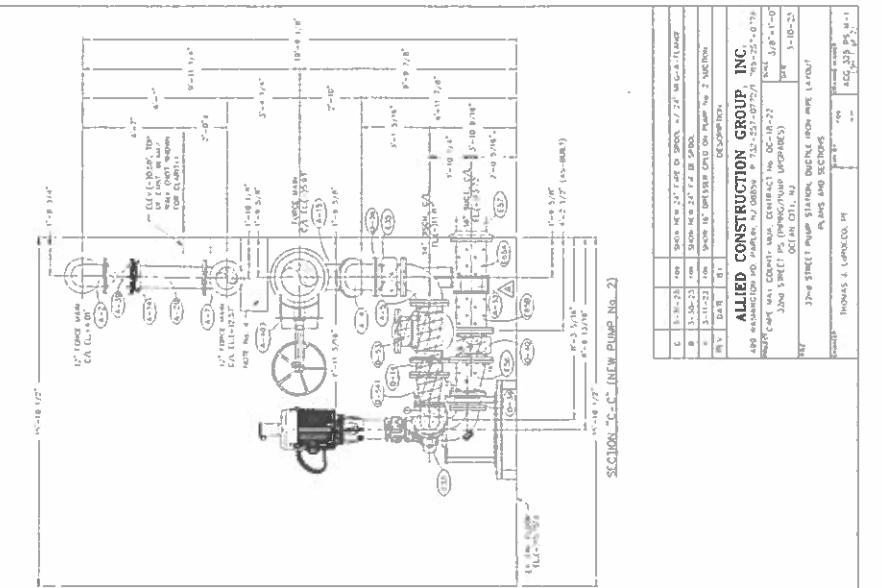
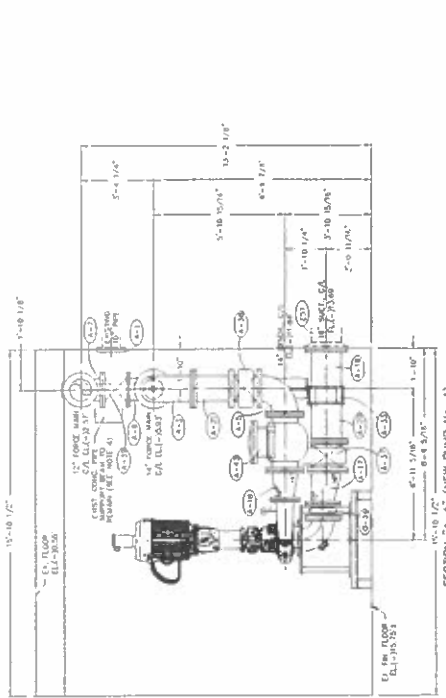
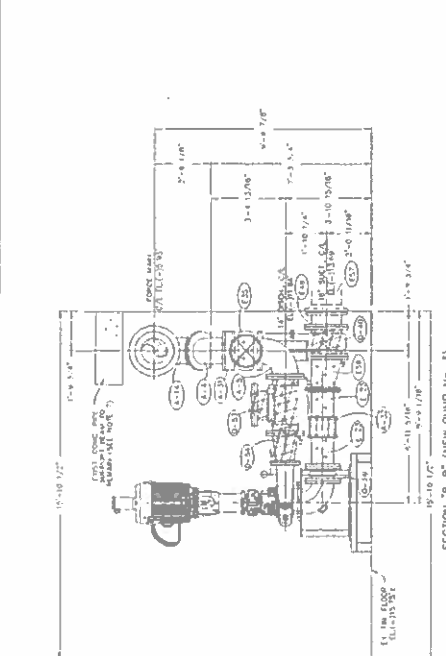

REV.	DATE	BY	DESCRIPTION
1	3-10-23	MM	ISSUE NEW SET OF DRAWINGS FOR 14'-25" NEW PUMP DISCHARGE
2	3-10-23	MM	ISSUE NEW SET OF DRAWINGS FOR 14'-25" NEW PUMP DISCHARGE
3	3-10-23	MM	ISSUE NEW SET OF DRAWINGS FOR 14'-25" NEW PUMP DISCHARGE
4	3-10-23	MM	ISSUE NEW SET OF DRAWINGS FOR 14'-25" NEW PUMP DISCHARGE

ALLIED CONSTRUCTION GROUP, INC.

440 WASHINGTON ROAD, SUITE 100, GAITHERSBURG, MD 20878-1077 (301) 251-0777

3200 STREET PUMP STATION, OFFICE FROM HERE LOCATED

PROJECT: 14'-25" NEW PUMP DISCHARGE (FORCE MAIN) HEADER @ ELEVATION 19.51

DRAWING NO: 14'-25" NEW PUMP DISCHARGE (FORCE MAIN) HEADER @ ELEVATION 19.51

DATE: 3-10-23

SCALE: AS SHOWN

Allied Construction Group, Inc.

499 Washington Road, Parlin NJ 08859
 Phone: 732-257-0772 Fax: 732-257-0774

Project: Job 325 32nd Street Pump Station, Cape May County MUA, Contract No. OC-18-22
 DRAWING: ACG 325 PS M-1 REV. B (Sheets 1 of 2 and 2 of 2), Plot date of 3/30/2023

3/10/2023
 3/31/2023

Rev. C

MK. NO.	QTY.	SIZE	DESCRIPTION	LENGTH	Interior Coating	Exterior Coating	Unit Weight	Release Date	Ship Date
E-1	3	24"	FLG Ductile Iron 90° Bend, 22" "C-F" (to remain in place)						
E-2	1	24"	Ductile Iron flange filler (to remain in place)	0'-4 1/8"					
E-3	1	24"	FLG Ductile iron tee, 22" "C-F" (NOTE: 2" NPT Tap to be placed at Position "R" for 2" screwed air release valve)						
E-4	1	24"	FLG x FLG Ductile iron pipe (to remain in place)	1'-4 1/8"					
E-7	1	24"	X 12" FLG Ductile iron concentric reducer, 24" "F-F" (to remain in place)						
E-11	1	14"	FLG Ductile iron 45° bend, 7 1/2" "C-F"						
E-19	1	24"	X 14" FLG Ductile iron concentric reducer, 24" "F-F" (reuse)						
E-23	2	12"	FLG x PE Ductile iron pipe (reuse as is, one piece may need to be field measured and cut to shorter length to fit new installation)	1'-9 1/4"					
E-26	1	24"	Dresser coupling (to remain in place)						
E-33	1	10"	FLG Ductile iron 45° bend, 6 1/2" "C-F"						
E-35	3	14"	FLG Gate valve, HW, non-rising stem, 15 1/16" "F-F"						
E-48	1	16"	FLG x PE Ductile iron pipe (reuse existing pipe as is)	1'-0 1/8"					
E-54	1	14"	X 10" FLG Ductile iron eccentric reducer, 16" "F-F"						
E-56	3	16"	X 12" FLG Ductile iron eccentric reducer, 18" "F-F"						
E-57	4	16"	TAP MJ x TAP MJ Ductile iron wall pipe w/WS						

Allied Construction Group, Inc.

499 Washington Road,
Parlin NJ 08859
Phone: 732-257-0772 Fax: 732-257-0774

Project: Job 325 32nd Street Pump Station, Cape May County MUA, Contract No. OC-18-22

3/10/2023

DRAWING: ACG 325 PS M-1 REV. B (Sheets 1 of 2 and 2 of 2), Plot date of 3/30/2023

Rev. C

3/31/2023

MK. NO.	QTY.	SIZE	DESCRIPTION	LENGTH	Interior Coating	Exterior Coating	Unit Weight	Release Date	Ship Date
E-63	1	12"	TAP MJ x TAP MJ Ductile iron wall pipe w/W/S						
E-65A	1	16"	PE x PE Ductile iron pipe (field measure and cut from exist. piece of FLG x PE ductile iron pipe 4'-5 1/2" long +/-)	2'-4"					
E-65B	1	16"	FLG x PE Ductile iron pipe (field measure and cut from exist. piece of FLG x PE ductile iron pipe 4'-5 1/2" long +/-)						
E-66A	1	16"	PE x PE Ductile iron pipe (field measure and cut from exist. piece of FLG x PE ductile iron pipe 4'-3 1/2" long +/-)	2'-2"					
E-66B	1	16"	FLG x PE Ductile iron pipe (field measure and cut from exist. piece of FLG x PE ductile iron pipe 4'-3 1/2" long +/-)	1'-9"					
E-67	2	24"	FLG x PE Ductile iron pipe (to remain in place)	1'-4 3/8"					
E-68	1	24"	FLG x FLG Ductile iron pipe (to remain in place)	1'-5 7/8"					
E-69			B This item deleted						
E-70	1	24"	FLG x PE Ductile iron pipe (to remain in place)	1'-2"					
ALL MATERIALS LISTED ABOVE ARE IDENTIFIED ON CONTRACT DRAWINGS									
AS EXISTING PIPE AND FITTINGS TO "REMAIN".									
PIPE & FITTINGS LISTED BELOW ARE THOSE MATERIALS FURNISHED BY THE									
OWNER AND INSTALLED BY ALLIED CONSTRUCTION GROUP									

Allied Construction Group, Inc.

499 Washington Road, Parlin NJ 08859
 Phone: 732-257-0772 Fax: 732-257-0774

Project: Job 325 32nd Street Pump Station, Cape May County MUA, Contract No. OC-18-22
 DRAWING: ACG 325 PS M-1 REV. B (Sheets 1 of 2 and 2 of 2), Plot date of 3/30/2023

3/10/2023
 3/31/2023

Rev. C

MK. NO.	QTY.	SIZE	DESCRIPTION	LENGTH	Interior Coating	Exterior Coating	Unit Weight	Release Date	Ship Date
A-1	1	10"	Ductile iron blind flange w/2" F-NPT @ center		Epoxy Prime	Epoxy Prime			
A-2	1	12"	FLG Ductile iron 90° bend, 12" "C-F"		Protecto 401®	Epoxy Prime			
A-3	1	14"	FLG Ductile iron long radius 90° base bend, base drilled & faced, 21 1/2" "C-F", 12 1/2" "C-Base"		Protecto 401®	Epoxy Prime			
A-4	3	14"	FLG Ductile iron 45° Bend, 7 1/2" "C-F"		Protecto 401®	Epoxy Prime			
A-5	3	14"	FLG Ductile iron 90° base bend, base drilled and faced, 14" "C-F", 12 1/2" "C-Base"		Protecto 401®	Epoxy Prime			
A-6	1	24"	FLG Ductile iron 90° base bend, base drilled, 22" "C-F", 18 1/2" "C-Base"		Protecto 401®	Epoxy Prime			
A-7	2	12"	FLG Ductile iron tee, 12" "C-F"		Protecto 401®	Epoxy Prime			
A-8	1	12"	Ductile iron blind flange		Protecto 401®	Epoxy Prime			
A-9	1	14"	x 12" FLG Ductile iron reducing tee, 14" "C-F"		Protecto 401®	Epoxy Prime			
A-10	1	14"	FLG Ductile iron 90° base bend, base drilled and faced, 14" "C-F", 12 1/2" "C-Base", NOTE: Flange opposite base to have bolt hole pattern rotated 45° from standard orientation (requires "one-hole" drilling)		Protecto 401®	Epoxy Prime			
A-11	1	20"	x 14" FLG Ductile iron concentric reducer, 20" "F-F"		Protecto 401®	Epoxy prime			
A-12	1	24"	x 14" FLG Ductile iron concentric reducer, 24" "F-F"		Protecto 401®	Epoxy prime			

Allied Construction Group, Inc.

499 Washington Road, Parlin NJ 08859
 Phone: 732-257-0772 Fax: 732-257-0774

Project: Job 325 32nd Street Pump Station, Cape May County MUA, Contract No. OC-18-22
 DRAWING: ACG 325 PS M-1 REV. B (Sheets 1 of 2 and 2 of 2), Plot date of 3/30/2023

3/10/2023
 Rev. C 3/31/2023

MK. NO.	QTY.	SIZE	DESCRIPTION	LENGTH	Interior Coating	Exterior Coating	Unit Weight	Release Date	Ship Date
A-13	1	24"	x 20" FLG Ductile iron concentric reducer, 24" "F-F"		Protecto 401®	Epoxy prime			
A-14	1	20"	x 14" FLG Ductile iron reducing wye, 8" "C-F" on short leg of run, 35" "C-F" on long leg of run and on branch		Protecto 401®	Epoxy prime			
A-15	2	24"	x 14" FLG Ductile iron reducing wye, 9" "C-F" on short leg of run, 40 1/2" "C-F" on long leg of run and on branch		Protecto 401®	Epoxy prime			
A-16	1	10"	Flange filler, (field measure for correct thickness, filler may need to be fabricated from steel plate)	5/16"		Epoxy Prime			
A-17	1	16"	x 12" FLG Ductile iron eccentric reducer, 18" "F-F"		Protecto 401®	Epoxy prime			
A-18	1	14"	x 10" FLG Ductile iron eccentric reducer, 16" "F-F"		Protecto 401®	Epoxy prime			
A-19	1	16"	PE x PE Ductile iron pipe	2'-5"	Protecto 401®	Epoxy Prime			
A-20	1	16"	FLG x PE Ductile iron pipe	2'-1"	Protecto 401®	Epoxy Prime			
A-21	1	14"	FLG x FLG Ductile iron pipe	1'-8"	Protecto 401®	Epoxy Prime			
A-22	1	14"	DI Flange filler	0'-5 3/4"	Protecto 401®	Epoxy Prime			
A-23	1	24"	FLG x FLG Ductile iron pipe	0'-9 3/8"	Protecto 401®	Epoxy Prime			
A-24	1	24"	DI Flange filler	0'-6 1/2"	Protecto 401®	Epoxy Prime			
A-25	1	12"	FLG x PE Ductile iron pipe	0'-11 5/8"	Protecto 401®	Epoxy Prime			
A-26	1	12"	FLG x FLG Ductile iron pipe	0'-9"	Protecto 401®	Epoxy Prime			
A-27	1	12"	FLG x FLG Ductile iron pipe	1'-10 1/8"	Protecto 401®	Epoxy Prime			
A-28	1	12"	FLG x PE Ductile iron pipe	6'-3 1/4"	Protecto 401®	Epoxy Prime			

Allied Construction Group, Inc.

499 Washington Road, Parlin NJ 08859
 Phone: 732-257-0772 Fax: 732-257-0774

Project: Job 325 32nd Street Pump Station, Cape May County MUA, Contract No. OC-18-22 3/10/2023
 DRAWING: ACG 325 PS M-1 REV. B (Sheets 1 of 2 and 2 of 2), Plot date of 3/30/2023 Rev. C 3/31/2023

MK. NO.	QTY.	SIZE	DESCRIPTION	LENGTH	Interior Coating	Exterior Coating	Unit Weight	Release Date	Ship Date
A-29	1	12"	FLG x PE Ductile iron pipe (to be field measured and cut to required length of 3'-4 3/4" long +/-)	3'-9"	Protecto 401®	Epoxy Prime			
A-30	1	12"	FLG x PE Ductile iron pipe (to be field measured and cut to required length of 6'-7 3/4" long +/-)	7'-0"	Protecto 401®	Epoxy Prime			
A-31	1	14"	DI Flange filler	0'-3 7/8"	Protecto 401®	Epoxy Prime			
A-32	1	12"	Bolted sleeve coupling equal to Smith-Blair Style 441 OMNI® cast coupling for DI pipe (no harness)		Epoxy Prime	Epoxy Prime			
A-33	3	16"	A Bolted sleeve coupling equal to Smith-Blair Style 441 OMNI® cast coupling for DI pipe (no harness)		Epoxy Prime	Epoxy Prime			
A-34	3	12"	EBAA Iron Series 2100 "MEGAFLANGE"(R) restrained flange adapter coupling		Epoxy Prime	Epoxy Prime			
A-35	1	24"	C EBAA Iron Series 2100 "MEGAFLANGE"(R) restrained flange		Epoxy Prime	Epoxy Prime			
A-36	2	12"	FLG rubber expansion joint w/SS split backing rings, SS control plates and restraint rods	0'-8"					
A-37	1	16"	FLG Resilient seat gate valve, non-rising stem, handwheel actuator, 16 1/16" "F-F"			Epoxy Prime			
A-38	1	14"	FLG Resilient seat, non-rising stem gate valve, w/chain wheel actuator, 15 1/16" "F-F"			Epoxy Prime			

Allied Construction Group, Inc.

499 Washington Road, Parlin NJ 08859
Phone: 732-257-0772 Fax: 732-257-0774

Project: Job 325 32nd Street Pump Station, Cape May County MUA, Contract No. OC-18-22

3/10/2023

DRAWING: ACG 325 PS M-1 REV. B (Sheets 1 of 2 and 2 of 2), Plot date of 3/30/2023

Rev. C

3/31/2023

MK. NO.	QTY.	SIZE	DESCRIPTION	LENGTH	Interior Coating	Exterior Coating	Unit Weight	Release Date	Ship Date
A-39	2	12"	FLG Resilient seat, non-rising stem gate valve, w/chain wheel actuator, 14" "F-F"			Epoxy Prime			
A-40	1	20"	FLG Knife gate valve, bevel gear & CW actuator, 4 1/2" "F-F"						
A-41	2	24"	FLG Knife gate valve, bevel gear & CW actuator, 4 1/2" "F-F"						
A-42	1	2"	Crispin Combination air release valve, F-NPT threaded ends						
A-43	1	14"	FLG APCO Check valve, L&W, 31" "F-F"						
A-44	2	2"	x 6" long 304SS SCH 40 pipe nipple, TBE						
A-45	1	2"	Threaded 304SS Ball valve, lever operator						
A-46	1	24"	C FLG x PE Ductile iron pipe	3'-6"	Protecto 401®	Epoxy Prime			
Joint Materials:									
Gaskets for flange joints shall be EPDM, bolts shall be ASTM A-307, Grade B heavy hex									
head bolts and heavy hex nuts (UNC), unless otherwise noted									
	1	12"	MJ accessory pack w/gland, gasket and 304 SS all-thread studs/SS nuts in lieu of regular T-bolts						
	4	16"	MJ accessory pack w/gland, gasket and 304 SS all-thread studs/SS nuts in lieu of regular T-bolts						
	4	10"	Flange joint accessory pack @ standard joint (gasket & CS nuts/bolts)						
	1	10"	Flange joint accessory pack @ standard joint w/ 5/16" filler flange (2 gaskets & CS nuts/bolts)						
	1	10"	Flange joint accessory pack @ tapped wall pipe flange (gasket & CS nuts/bolts)						

Allied Construction Group, Inc.

499 Washington Road, Parlin NJ 08859
 Phone: 732-257-0772 Fax: 732-257-0774

Project: Job 325 32nd Street Pump Station, Cape May County MUA, Contract No. OC-18-22
 DRAWING: ACG 325 PS M-1 REV. B (Sheets 1 of 2 and 2 of 2), Plot date of 3/30/2023

3/10/2023

Rev. C 3/31/2023

MK. NO.	QTY.	SIZE	DESCRIPTION	LENGTH	Interior Coating	Exterior Coating	Unit Weight	Release Date	Ship Date
	9	12	Flange joint accessory pack @ standard joint (gasket & CS nuts/bolts)						
	2	12"	Flange joint accessory pack @ magnetic flowmeter w/grounding rings (2 gaskets & CS nuts/bolts)						
	6	12"	Flange joint accessory pack @ flg to rubber EJ w/ control plates (no gasket, CS nuts/bolts)						
	4	12"	Flange joint accessory pack @ pump flg to rubber EJ w/control plates (no gasket, CS nuts/bolts)						
	20	14"	Flange joint accessory pack @ standard joint (gasket & CS nuts/bolts)						
	2	14"	Flange joint accessory pack @ standard joint w/ 3/8" filler flange (2 gaskets & CS nuts/bolts)						
	1	14"	Flange joint accessory pack @ standard joint w/ 2 5/8" filler flange (2 gaskets & CS nuts/bolts)						
	1	14"	Flange joint accessory pack @ standard joint w/ 3 7/8" filler flange (2 gaskets & CS nuts/bolts)						
	1	14"	Flange joint accessory pack @ standard joint w/ 5 3/4" filler flange (2 gaskets & CS nuts/bolts)						
	2	14"	Flange joint accessory pack @ magnetic flowmeter w/grounding rings (2 gaskets & CS nuts/bolts)						
	8	16"	Flange joint accessory pack @ standard joint (gasket & CS nuts/bolts)						
	1	20"	Flange joint accessory pack @ standard joint (gasket & CS nuts/bolts)						
	2	20"	Flange joint accessory pack @ DI flange to tapped flange on knife gate valve (gasket & CS cap screws)						
	6	24"	C Flange joint accessory pack @ standard joint (gasket & CS nuts/bolts)						
	4	24"	Flange joint accessory pack @ DI flange to tapped flange on knife gate valve (gasket & CS cap screws)						
	1	24"	Flange joint accessory pack @ standard joint w/ 6 1/2" filler flange (2 gaskets & CS nuts/bolts)						
	4	24"	Exist. standard flange joint (unknown if fittings are to be dismantled and reassembled?)						
	1	24"	Exist. standard flange joint w/ 4 1/8" filler flange (unknown if fittings are to be dismantled/reassembled?)						

ALLIED

CONSTRUCTION GROUP INC

499 Washington Road, Parlin, NJ 08859
 tel 732.257.0772 fax 732.257.0774
 www.ALLIEDCONSTRUCTGROUP.COM

TITLE: Contingency Items 11.3 and 11.4 & 11.5

PROJECT: 325 - CMCMUA
 Ocean City Region 32nd Street Pump Station
 Piping & Pump Upgrades

TO: Attn: George Hann, P.E.
 Cape May County Municipal Utilities Authority
 1523 Route 9 North
 Cape May Court House, NJ 08210

PROPOSAL NO.

DATE: 08/07/2023

JOB: 325

CONTRACT/PO: OC-18-22

SUBMITTED: 08/07/2023

COMPLETED:

REQUIRED: 08/10/2023

DESCRIPTION

We are submitting herein the pricing for Contingency Items 11.3, 11.4, and 11.5 as requested in the review comments for Submittal 402319-04. The work for Item 11.3 is a No Cost Item.

Num	Item	Description	Ref	Qty	Unit	Unit Price	Amount
1	11.3	Replace Support PS12-DP4 & PS12-DP5 with Support CH12-DP6 & CH12-DP7 and Add Support CH12-DP8 at No Cost		1.000	LS	0.00	0.00
2	11.4	Add Supports at Pump #1 PS16-SP3 & PS16-SP4; Add Supports at Pump #2 PS16-SP5 & PS16-SP6; Add Supports at Pump #3 PS16-SP& & PS12-SP1		1.000	LS	7,660.00	7,660.00
3	11.5	Provide new supports PS24-DI1 & PS24-DI2		1.000	LS	6,343.00	6,343.00
						Total:	\$14,003.00

ACCEPTED

Matthew
 Marcinczyk

By: _____

Matthew Marcinczyk, P.E.

Date: _____

08/07/2023

Digitally signed by Matthew Marcinczyk
 DN: cn=Matthew Marcinczyk, c=US, o=Allied
 Construction Group, Inc
 email=mmarcinczyk@alliedconstrgroup.com
 Date: 2023.08.07 14:50:43 -0400

By: _____

Date: _____

ALLIED CONSTRUCTION GROUP, INC

499 Washington Road

Parlin, NJ 08859

Cape May County Utilities Authority

Contract OC-18-22

32nd Street Pumping Station Piping & Pumps Upgrades

Contingency Item 11.4

DESCRIPTION	Qty.	Unit	Rate	Total
Payroll Costs - Paragraph 11.4.1				
Project Manager	0	Hrs	\$ 175.00	\$ -
Plumber Foreman	13	Hrs	\$ 130.06	\$ 1,690.78
Plumber	13	Hrs	\$ 120.03	\$ 1,560.39
Subtotal:				\$ 3,251.17
Materials & Equipment - Paragraph 11.4.2				
Specialty Support	1	LS	\$ 1,422.00	\$ 1,422.00
Misc. Anchors & Grout	1	LS	\$ 200.00	\$ 200.00
Subtotal:			\$ 1,622.00	\$ 1,622.00
Total:				\$ 4,873.17
Contractor's Fee on Payroll, Materials & Equipment Costs Per Paragraph 11.6.1				
Contractor's Fee (20%)				\$ 974.63
Total:				\$ 5,847.80
Subcontractors Costs - Paragraph 11.4.3				
Painting	1	LS	\$ 900.00	\$ 900.00
Subtotal:				\$ 900.00
Contractor's Fee on Subcontractors Paragraph 11.6.2				
Contractor's Fee on Subcontractors (10%):				\$ 90.00
Total:				\$ 990.00
Supplemental Costs -Paragraph 11.4.5				
Consultant - Outside Engineering	2	Hr	\$ 70.00	\$ 140.00
Consultant - Pipe & Equipment Detailer	10.5	Hr	\$ 65.00	\$ 682.50
Consultant - CPM Schedule (Add/Update)	0.25%	LS	\$ -	\$ -
Consultant - Safety	0.25%	LS	\$ -	\$ -
Subtotal:				\$ 822.50
Total for Bond & Insurance Amounts:				\$ 7,660.30
Insurance Cost - Not Allowable				
11.01-A-5-I - Insurance - Pollution Liability Policy	0.10%	X	\$ -	\$ -
11.01-A-5-I - Insurance - Umbrella Policy (Cost of Subs)	0.13%	X	\$ -	\$ -
11.01-A-5-I - Insurance - G.L. Policy (Cost of Subs)	0.51%	X	\$ -	\$ -
Total:				\$ 7,660.30
Bond Cost - Not Allowable				
Bond Premium (1.6% for total amount less than \$500,000)				\$ -
Grand Total:				\$ 7,660.30

Say Total: \$ 7,660

ALLIED CONSTRUCTION GROUP, INC
499 Washington Road
Parlin, NJ 08859

Cape May County Utilities Authority

Contract OC-18-22
32nd Street Pumping Station Piping & Pumps Upgrades
Contingency Item 11.5

DESCRIPTION	Qty.	Unit	Rate	Total
Payroll Costs - Paragraph 11.4.1				
Project Manager	0	Hrs	\$ 175.00	\$ -
Plumber Foreman	8	Hrs	\$ 130.06	\$ 1,040.48
Plumber	8	Hrs	\$ 120.03	\$ 960.24
Subtotal:				\$ 2,000.72
Materials & Equipment - Paragraph 11.4.2				
Specialty Support	1	LS	\$ 1,910.00	\$ 1,910.00
Subtotal:			\$ 1,910.00	\$ 1,910.00
Total:				\$ 3,910.72
Contractor's Fee on Payroll, Materials & Equipment Costs Per Paragraph 11.6.1				
Contractor's Fee (20%)				\$ 782.14
Total:				\$ 4,692.86
Subcontractors Costs - Paragraph 11.4.3				
Painting	1	LS	\$ 900.00	\$ 900.00
Subtotal:				\$ 900.00
Contractor's Fee on Subcontractors Paragraph 11.6.2				
Contractor's Fee on Subcontractors (10%):				\$ 90.00
Total:				\$ 990.00
Supplemental Costs -Paragraph 11.4.5				
Consultant - Outside Engineering	2	Hr	\$ 70.00	\$ 140.00
Consultant - Pipe & Equipment Detailer	8	Hr	\$ 65.00	\$ 520.00
Consultant - CPM Schedule (Add/Update)	0.25%	LS	\$ -	\$ -
Consultant - Safety	0.25%	LS	\$ -	\$ -
Subtotal:				\$ 660.00
Total for Bond & Insurance Amounts:				\$ 6,342.86
Insurance Cost - Not Allowable				
11.01-A-5-I - Insurance - Pollution Liability Policy	0.10%	X	\$ -	\$ -
11.01-A-5-I - Insurance - Umbrella Policy (Cost of Subs)	0.13%	X	\$ -	\$ -
11.01-A-5-I - Insurance - G.L. Policy (Cost of Subs)	0.51%	X	\$ -	\$ -
Total:				\$ 6,342.86
Bond Cost - Not Allowable				
Bond Premium (1.6% for total amount less than \$500,000)				\$ -
Grand Total:				\$ 6,342.86

Say Total: \$ 6,343



1921 Washington Road, Parkersburg, NJ 08654
(609) 732.2517.0772 fax 732.251.0774
www.alliedconstructiongroup.com

PROJECT: 325 - CMCMUA
Ocean City Region 32nd Street Pump Station
Piping & Pump Upgrades

TITLE: Pipe Support Layout Drawings & Comments

TO: Cape May County Municipal Utilities Authority
1523 Route 9 North
Cape May Court House, NJ 08210

ATTN: Thomas J. LaRocco, P.E.

SUBMITTAL NO.: 402319-04

DATE: 08/02/2023

JOB: 325

DIVISION: 40

TRADE: Process

SECTION: 402319

RE-SUBMITTAL:

<input checked="" type="checkbox"/> Shop Drawings <input type="checkbox"/> Letter <input type="checkbox"/> Plans <input type="checkbox"/> Plans	<input type="checkbox"/> Samples <input type="checkbox"/> Specifications <input type="checkbox"/> Other <input type="checkbox"/> Other
--	---

GDRES.	SECTION	DATE	DESCRIPTION
1	402319	06/07/23	Pipe Support Layout Drawings & Comments

REMARKS:

APPROVED FOR CONTRACT REQUIREMENTS

The Contractor's signature below indicates that he/she has checked the shop drawing with the Contract Drawings and Specifications and found it to meet the requirements of the same including dimensions, and that the Contractor's guarantees fully complies to the specified material or equipment

Signed by: Matthew Marcinczyk, P.E.

Review Comments.
 Item 2 - We are O.K. with replacing PS12-D-P4 + PS12-OP6 with CH-OP6 and CH-OP7 and adding CH-OP8, all at no cost Cape May County Municipal Utilities Authority
 to the owner
 Item 3 We have no objection to adding these supports, please provide us for an estimate for this work.
 for review and comment.
 Item 4 Please provide us with a proposal for an alternative support system for the switch out at the plug valve.
 The balance shall remain as is except for painting and making elevation adjustments
 - Drawing comments - See drawings

Contract No. PC-18-22
 Submit No. 302319-04
 Review is for general compliance with design concept and arrangement of the project. Contractor is responsible for conformity with the contract documents, construction means and methods, quantities, construction means and end results, coordination with other trades.
 No Exceptions Taken
 Minor Corrections Noted
 Major Corrections Noted
 Date 8/17/23 by [Signature]

ACG Job No. 325

Cape May County MUA, Contract # OC-18-22,
32nd Street Pump Station Piping/Pump Upgrades

Subject: Allied Review Notes/Comments for Pipe Support Submittal

Attachments:

- Allied Dwg. # ACG 325 PS M-2, Sheet 1 of 2, Rev A Dated 04-27-2023
- Allied Dwg. # ACG 325 PS M-2, Sheet 2 of 2, Rev A Dated 04-27-2023
- Allied Photo #1 Dated 04/28/2023.
- Allied Photo #2 Dated 04/28/2023

Review Comments:

1. The attached Dwg's follow the Contract Dwg's with types and installation locations for "NEW" supports we are to provide and install per our Contract. Included also on our Dwg's are the ACG Supports Details that will be utilized for fabrication and includes materials, dimensions, prep, finishes, etc
2. Based on ACG's Fabricated Pipe layout there are several changes we included for a few of the original pipe supports that we believe are more appropriate i.e. for original supports # PS12-DP4 and PS12-DP5 we will provide our Supports # CH12-DP6 and # CH12-DP7. Also, we added an additional support that we feel is required as shown on our Dwg. as CH12-DP8. For this item we propose to make these changes in types/quality as noted as "No Change in Contract Price" if acceptable as submitted
3. On ACG's Dwg's we have shown "additional" supports that we believe should also be installed to support the 12" & 16" piping at Pump # 1, 2 & 3 since the existing concrete supports are not re-used nor can they be considered for re-use. The added supports we suggest on our Dwg's include:
 - Pump # 1 adding PS18-SP3 & PS18-SP4
 - Pump # 2 adding PS18-SP5 & PS18-SP6
 - Pump # 3 adding PS18-SP7 & PS12-SP1Please review and let us know if you agree and if so, we will prepare an estimate to supply and install these added supports.
4. Allied's attached Photos # 1&2 of the existing 24" pipe header at North/East well areas. These are existing supports that we are to re-adjust their elevations, make minor revisions, and reinstall. There are five (5) existing supports that you should review the original support designs/materials used along with existing conditions for their capacity loadings.

current anchorage as installed, etc. Should you feel that it may be time to consider replacing these supports since we are revising this particular piping area please let us know along with any possible replacement support concepts or ideas.

5. Upon Approval and return of this submittal we provide Detailed Fabrications Dwg's for additional submittal approval before we release the supports for Fabrication/Delivery.

Specialty Support Systems, Inc.
Pipe Supports & Misc. Metals Fabrication

TELEPHONE ORDER _____
SALES ORDER _____
QUOTE

QUOTE 6-19-22
REV. 6-23-23

JOB NAME	CUSTOMER'S ORDER NO. & DATE	ORDER TAKEN BY & DATE	IMMEDIATE APPROVAL
	325-MC-04		
SOLD TO	ALLIED CONSTRUCTION	SHIP TO	32ND STREET PS.
	DANIELLE		
	RICH		CAPEMAY, NJ

SHIP VIA	FREIGHT	JOB NO.	ORDERED
OT	<input type="checkbox"/> PPD <input type="checkbox"/> PPD-CHG <input type="checkbox"/> COLL		
SPECIAL INSTRUCTIONS	<p>#1A22.00 PCD 2B PS-16 SP-3 A 6 47 12 6 PCS PS-24 DP-1 & DP-2 2 POS 100 1910</p>		
SHIP FROM STOCK	<input type="checkbox"/> DIRECT		

QUANTITY	DESCRIPTION SIZE-FIGURE NO., ETC.	LINE NO.	NO. NO.
1	DRAWING #7		
4 ✓	DETAIL #1 PS-14BE-1,2,3,4		
1 ✓	DETAIL #2 PS-14BE-5 HDG		
	DRAWING #8		
4 ✓	DETAIL #3 PS-14CV-1,2,3,4 HDG		
2 ✓	DETAIL #4 & B (PS-11a SP-13 & 14) HDG (237)		
1 ✓	DETAIL #6 PS-14BT-1 HDG		
5 ✓	DETAIL #8 PS-02AR-1,2,3,4,5 HDG		
1 ✓	DETAIL #9 PS-02AR-6 HDG		
NEW 2 ✓	DETAIL #7 (PS-24DP-1 & DP-2) HDG (955) (1910)		
2 ✓	DETAIL #10 PS-12BT-1 & DP-3 HDG		
	DRAWING #9		
1 ✓	NEW PUMP PEDESTAL EPOXY		
NEW 3 ✓	CH-1 DP-6,7,8 10 (2-RL) HDG		
NEW 1 ✓	(PS-12SP-1) (237)		
1 ✓	FREIGHT TO CAPEMAY, NJ.		
17	(1) ALL SUPPORTS ARE HOT DIP GALV. UNO		
18	(2) 3/16" ANCHORS ARE INCLUDED		
19	EPOXY BY CONTRACTOR.		
20	(3) NEED DETAIL FOR...		

6-23-23

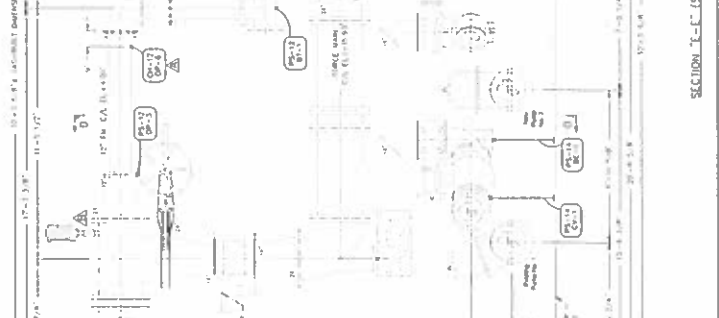
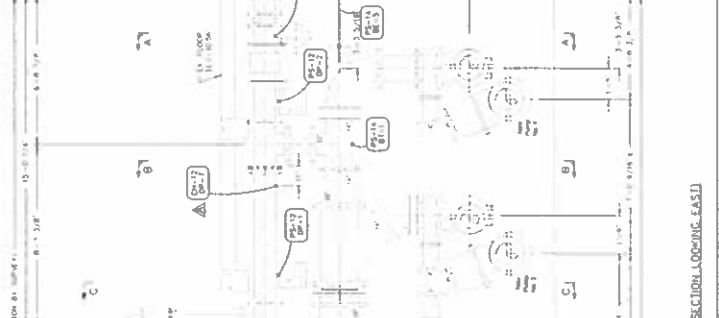
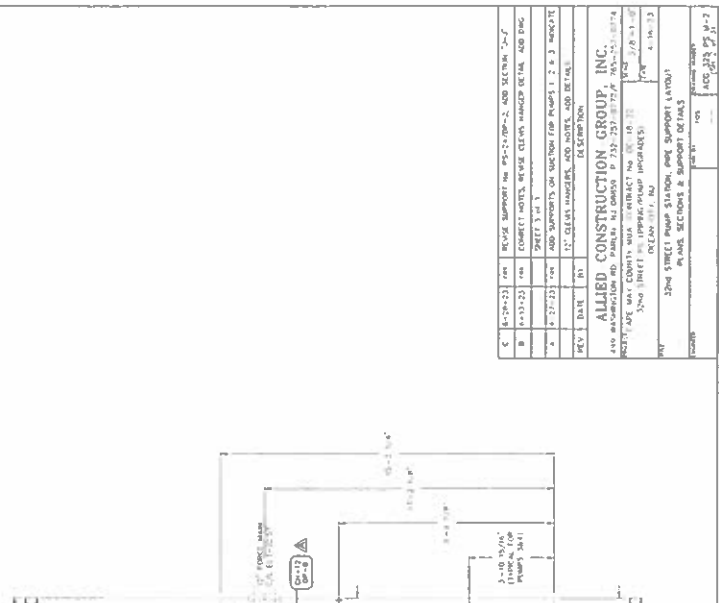
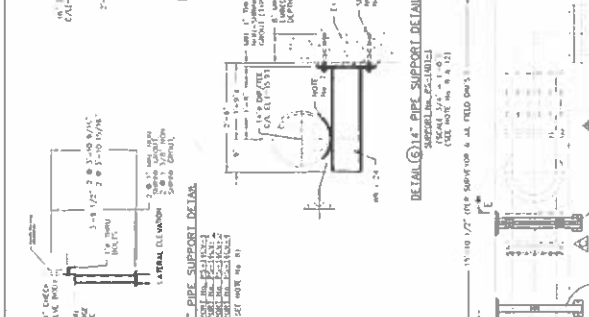
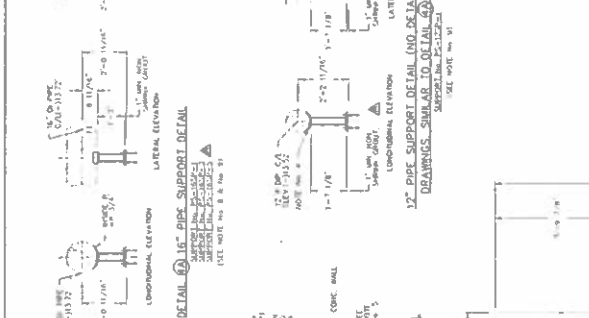
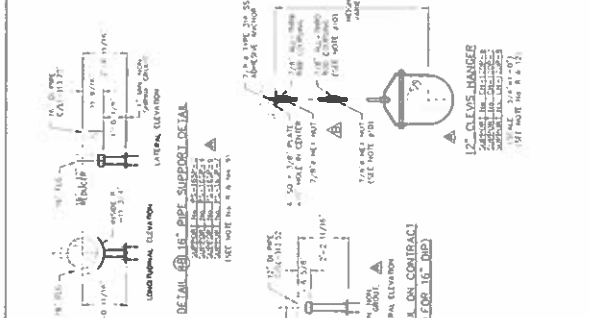
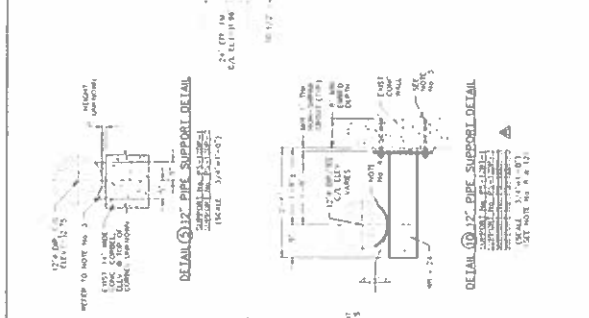
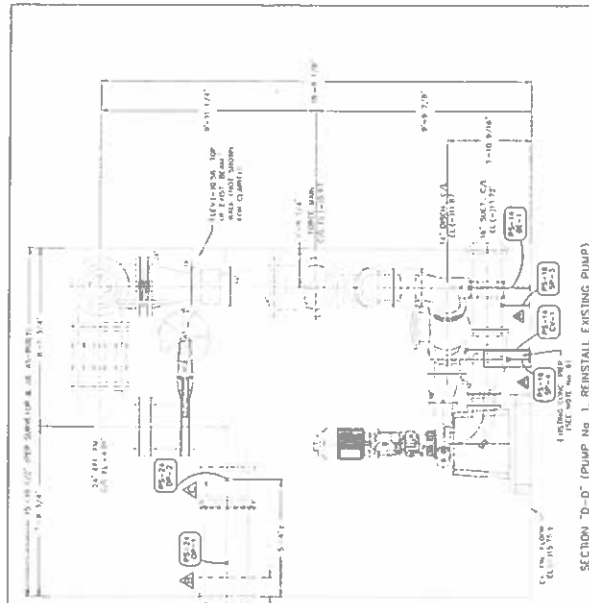

REV.	DATE	BY	DESCRIPTION
A	10-27-22	YAS	REVISE SUPPORT FOR PUMP NO. 1, 2, AND SECTION 7-7
B	10-27-22	YAS	CORRECT NOTES, REUSE CLEARANCE DETAIL, AND PING
C	10-27-22	YAS	ADJUST SUPPORTS ON SECTION FOR PUMPS 1, 2 & 3. REPEAT
D	10-27-22	YAS	12" CLEAR MANGER, AND VALVE, AND DETAIL

ALLIED CONSTRUCTION GROUP, INC.
 100 WEST 10TH STREET, SUITE 1000, DENVER, CO 80202
 (303) 733-1100
 WWW.ALLIEDCONSTRUCTION.COM

2ND STREET PUMP STATION, PUMP SUPPORT LAYOUT
 P. 14-15, SECTIONS A SUPPORT DETAILS

PLAN VIEW NEW 12" & 24" FORCE MAIN ABOVE INTERMEDIATE FLOOR LEVEL, FLOOR LEVEL=10.522'

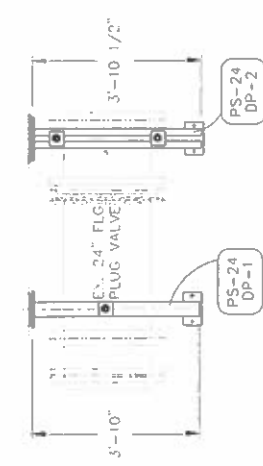

PARTIAL PLAN VIEW
 REFERENCE ACG DRAWING #ACG 325 PS M-2 (SHEET 2 of 2) TOP LOCATION OF 24" FORCE MAIN DISCHARGE

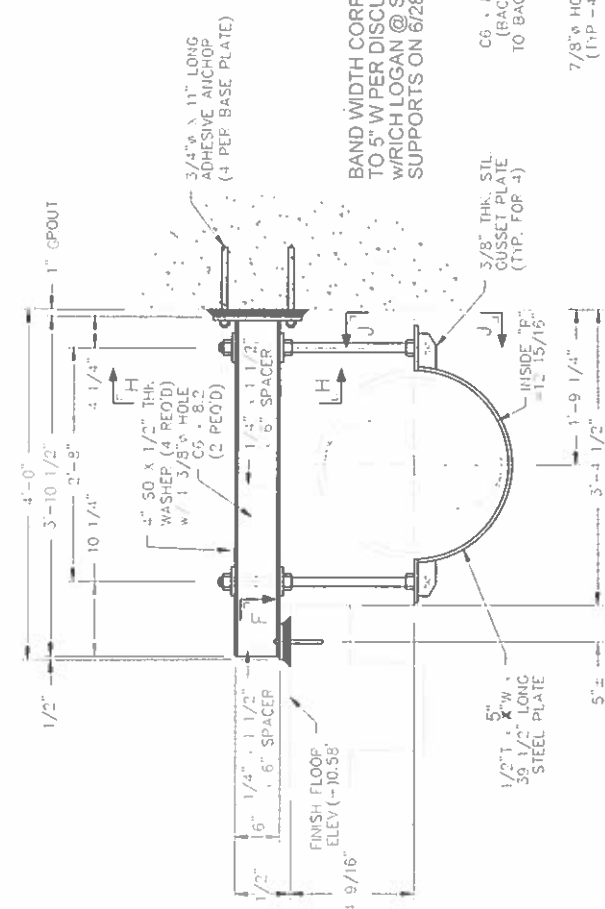

ELEVATION VIEW: SUPPORT NO. PS-24/DP-2

QUANTITY OF ONE (1) REQUIRED
 (FIGURED 7000#± DEAD LOAD)

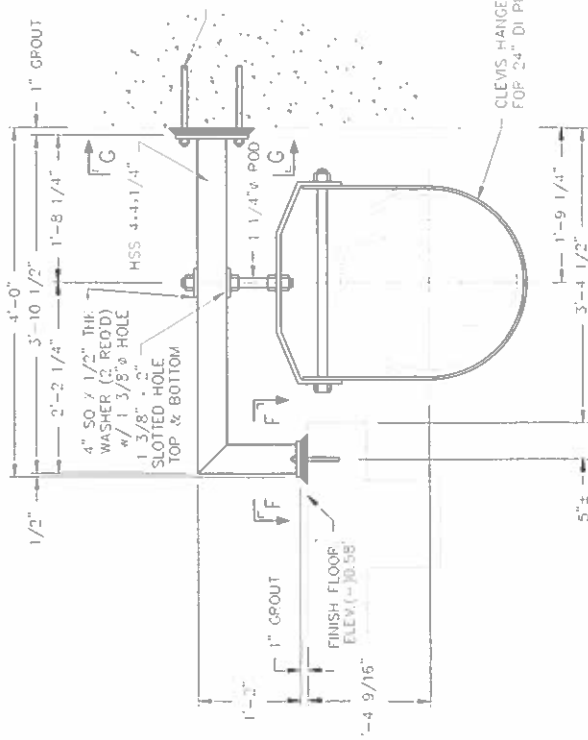

ELEVATION VIEW: SUPPORT NO. PS-24/DP-1

QUANTITY OF ONE (1) REQUIRED
 (FIGURED 17000#± DEAD LOAD)

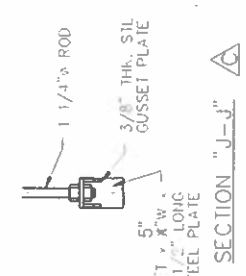

SECTION "J-J"

BAND WIDTH CORRECTED TO 5" W PER DISCUSSION W/RICH LOGAN @ SPECIALTY-0 SUPPORTS ON 6/28/23.

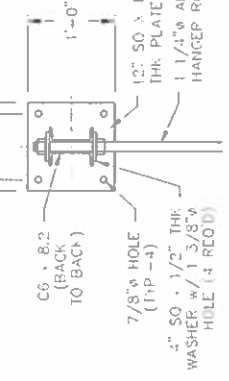

SECTION "H-H" (BASE PLATE)
 (1 PLATE REQUIRED)

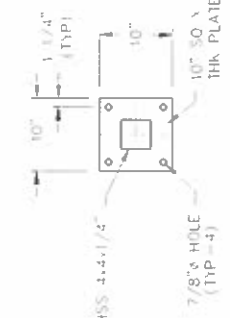

SECTION "G-G" (BASE PLATE)
 (1 PLATE REQUIRED)

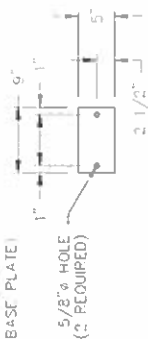

SECTION "F-F" (BASE PLATE)
 (2 PLATES REQUIRED)

REV	DATE	BY	DESCRIPTION
1	04-28-23	AK	REVISE SUPPORT NO. PS-24/DP-2 AND SECTION "J-J"
2	04-28-23	AK	COMPLETE NOTES, REVISE CLEVIS HANGER DETAIL, ADD DOP.
3	04-28-23	AK	SHEET 3 of 4

ALLIED CONSTRUCTION GROUP, INC.
 1400 WASHINGTON RD. PARK, NJ 08054 P: 732-237-8772 F: 732-237-8774
 3000 STREET PUMP STATION DETAILS FOR
 100' DIAMETER FORCE MAIN (PEP)
 FOR PEP SUPPORTS ON 24" FORCE MAIN (PEP)

Cape May County Municipal Utilities Authority

RESOLUTION NO. 109-23

RESOLUTION AUTHORIZING THE AWARD OF CONTRACT WW-EQUIP-26-23 – FURNISH AND DELIVER SLUDGE COLLECTION COMPONENTS FOR VARIOUS WASTEWATER TREATMENT FACILITIES TO BRENTWOOD INDUSTRIES, INC.

WHEREAS, the Cape May County Municipal Utilities Authority ("CMCMUA"/"Authority") had published an Advertisement for Bids for WW-EQUIP-26-23 – Furnish and Deliver Sludge Collection Components for Various Wastewater Treatment Facilities ("Contract") and furnished detailed Bid Specifications for said Contract to potential Bidders; and,

WHEREAS, the Authority received one (1) Bid in accordance with the Advertisement for Bids for the Contract and publicly opened said Bid on July 18, 2023; and,

WHEREAS, the CMCMUA's Purchasing Agent and Wastewater Program Manager have reviewed the Bid submitted by the sole Bidder, Brentwood Industries, Inc., and have determined that it is a responsive Bid in accordance with the Advertisement for Bids and Bid Specifications for said Contract; and,

WHEREAS, the Authority's General Legal Counsel has reviewed the Bid submitted by Brentwood Industries, Inc., and has opined, after researching the applicable law, that their Bid complied with the Bid Specifications of said Contract; and,

WHEREAS, the CMCMUA's Chief Financial Officer and Executive Director have concurred with said determination; and,

WHEREAS, the Cape May County Municipal Utilities Authority has therefore determined that Brentwood Industries, Inc., 500 Spring Ridge Drive, Wyomissing, PA 19610 is a responsible Bidder, having submitted a responsive Bid in accordance with the Advertisement for Bids and Bid Specifications for Contract WW-EQUIP-26-23 in the total not-to-exceed amount of \$863,058.00; and,

WHEREAS, the Authority's Chief Financial Officer has certified that funds are available for such services.

NOW, THEREFORE, BE IT RESOLVED by the Cape May County Municipal Utilities Authority, a body corporate and politic, as follows:

1. The provisions of the WHEREAS clauses set forth above are incorporated herein by reference and made a part hereof.
2. Contract WW-EQUIP-26-23 identified in the Preamble of this Resolution, in substantially the same form as now on file with the Authority's Office Manager, is hereby awarded to Brentwood Industries, Inc., at the total contract amount of \$863,058.00.
3. The Authority's Executive Director, or Deputy Director, is hereby authorized and directed to execute said Contract.

BE IT FURTHER RESOLVED in accordance with N.J.A.C. 5:30-5.5(b)2, no amount of Furnish and Deliver Sludge Collection Components for Various Wastewater Treatment Facilities under Contract WW-EQUIP-26-23 shall be chargeable or certified until such time as they are actually ordered or otherwise called for. Prior to authorizing any work under this Contract, a certification of available funds shall be made by the Authority's Chief Financial Officer upon receipt of a properly executed Purchase Order and said certification shall be attached to the file copy of the Purchase Order. Total expenditures under this contract shall not exceed \$863,058.00.

	Motion	Second	Yes	No	Abstain	Absent
Mr. Burns						
Ms. Callinan						
Ms. Heenan						
Mr. Matalucci						
Mr. Rixey						
Ms. Saduk						
Mr. Betts						

I hereby certify the foregoing to be a true and correct copy of Resolution No. **109-23** adopted by the Cape May County Municipal Utilities Authority at its Regular Meeting on the **6th** day of **September 2023**.

Assistant Corporate Secretary

ENGINEER'S ESTIMATE		OPENING DATE		BRENWOOD INDUSTRIES, INC.						
\$900,000.00		TUESDAY, JULY 16, 2023 @ 2:00PM								
WW-EQUIP-26-23 Furnish and Deliver Various Sludge Collection Components for Various Wastewater Treatment Facilities		CONTRACT NUMBER AND TITLE								
ITEM	DESCRIPTION	QUANTITY	UNIT PRICE	EXT. PRICE	UNIT PRICE	EXT. PRICE	UNIT PRICE	EXT. PRICE	UNIT PRICE	EXT. PRICE
1	Furnish and deliver equipment for primary clarifier tank systems as specified at the Wildwood/Lower Wastewater Treatment Facility	2	151,562.00	303,124.00	0.00	0.00	0.00	0.00	0.00	0.00
2	Furnish and deliver equipment for secondary clarifier tank systems as specified at the Wildwood/Lower Wastewater Treatment Facility	2	170,659.00	341,318.00	0.00	0.00	0.00	0.00	0.00	0.00
3	Furnish and deliver equipment for primary clarifier tank cross collector systems as specified at the Seven Mile Beach/Middle Wastewater Treatment Facility	2	27,625.00	55,250.00	0.00	0.00	0.00	0.00	0.00	0.00
4	Furnish and deliver equipment for secondary clarifier tank system as specified at the Seven Mile Beach/Middle Wastewater Treatment Facility	1	138,366.00	138,366.00	0.00	0.00	0.00	0.00	0.00	0.00
5	Allowance as set by the Authority (\$25,000)	1	25,000.00	25,000.00	0.00	0.00	0.00	0.00	0.00	0.00
TOTAL AMOUNT BID				\$ 863,056.00	PROVIDED		PROVIDED		PROVIDED	0.00
	BIDDER'S CHECKLIST	REQUIRED	PROVIDED							
	STATEMENT OF OWNERSHIP	X	Y							
	NON-COLLISION AFFIDAVIT	X	Y							
	PROPOSAL FORM(S)	X	Y							
	ADDENDA ACKNOWLEDGEMENT	X	Y							
	BID GUARANTEE	X	Y							
	BIDDER'S CHECKLIST - DOCUMENT A		N							
	N.J. BUSINESS REGISTRATION CERTIFICATE		N							
	PROHIBITED RUSSIA-BELARUS ACTIVITIES & IRAN INVESTMENT ACTIVITIES		Y (IRAN ONLY)							
	IRS FORM W-9		N							
	BIDDER'S CHECKLIST - DOCUMENT B		N							
	MANDATORY AFFIRMATIVE ACTION		N							
	INSURANCE CERTIFICATE(S)		N							

**CAPE MAY COUNTY MUNICIPAL UTILITIES AUTHORITY
CONTRACT FACT SHEET**

PROJECT INFORMATION

Project Name: Furnish and Deliver Sludge Collection Components for Various Wastewater Treatment Facilities
Purpose and Scope of Contract: The purpose and scope of this contract is for a vendor to furnish and deliver all materials (chain-and-flight equipment, sprockets, spindles, guide rails, hardware, and supports) and appurtenances for two (2) primary clarifier systems and two (2) secondary clarifier systems at the Wildwood/Lower WWTP and one (1) primary clarifier system and one (1) secondary clarifier system at the Seven Mile Beach/Middle WWTP.

PROCUREMENT INFORMATION

Contract Type: Procurement (Goods and Services) Professional Services
 Construction Non-Professional Services

Contract Number: WW-EQUIP-26-23 **Term of Contract:** One (1) year **Option to Renew:** No Yes:

Bid Guarantee: No Yes **Consent of Surety:** No Yes

Liquidated Damages: No Yes: Basis:

Engineer's Estimate: \$925,000.00

Advertisement Date: June 27, 2023 **Opening Date:** July 18, 2023

Contract Award Basis: Lowest Responsible Bidder Best Value Cooperative Pricing System
 Highest Ranking Score Negotiated

Recommendation: Award
 Exercise 1 year option to renew under original Contract Terms and Conditions, Option Dates: ;
Options to Renew remaining:
 Reject, Basis:

CONTRACTOR/VENDOR INFORMATION

Contractor/Vendor: Brentwood Industries, Inc. **Address:** 500 Spring Ridge Drive
Wyomissing, PA 19610

BUDGET INFORMATION

Program: Wastewater Solid Waste Administration

Funding:
 Operating Budget Capital SW Building & Site Maintenance SW Equipment Fund

Contract Value, Not-To-Exceed: \$863,058.00

Contract Spending Previous Contract Year: N/A



Joshua Palombo, Wastewater Program Manager

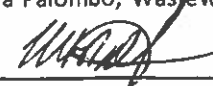

Robert P. Donato, Chief Financial Officer

8/23/23

Date

8/31/2023

Date



Kevin W. McGahey, Purchasing Agent



Joseph V. Rizzuto, Executive Director

08-21-2023

Date

08/24/23

Date

WADE, LONG, WOOD & LONG, LLC

Howard C. Long, Jr. †
Daniel H. Long †±◇
Christopher F. Long †◇

John A. Moustakas †◇

John D. Wade †
OF COUNSEL
Leonard J. Wood, Jr. †
OF COUNSEL

† Admitted to NJ Bar
± Admitted to Washington DC Bar
◇ Admitted to PA Bar

August 25, 2023

Joseph V. Rizzuto, Executive Director
CAPE MAY COUNTY MUNICIPAL
UTILITIES AUTHORITY
P.O. Box 610
Cape May Court House, NJ 08210

**RE: Furnish and Deliver Sludge Collection Components for Various Wastewater
Treatment Facilities
WW-EQUIP-26-23**

Dear Mr. Rizzuto:

I. INTRODUCTION

I have reviewed the documents provided regarding the bid submission with respect to the contract for WW-EQUIP-26-23, to Furnish and Deliver Sludge Collection Components for Various Wastewater Treatment Facilities on behalf of the Cape May County Municipal Utilities Authority (“CMCMUA” and/or “Authority”). The CMCMUA received one (1) bid for this Contract. The sole bid was received on Tuesday, July 18, 2023, at 2:00 p.m. as follows:

<u>Vendor</u>	<u>Total Amount Bid</u>
I. Brentwood, Industries, Inc.	\$863,058.00
<u>Engineer’s Estimate:</u>	<u>\$900,000.00</u>

II. FACTUAL ANALYSIS

The bid specifications sought bids for the furnishing and delivery of all materials, equipment, hardware, supports and appurtenances for chain and flight equipment as specified in order to make ready for installation and operation. See Bid Specifications Section IV(1), Technical Specifications, Description/Summary. The proposed equipment will replace the Authority’s existing clarifier components and will be installed by the Authority using “in-house” forces. The specifications make clear that the scope of the contract is limited to the purchase, supply, delivery, start-up and training of the equipment, and no installation work is required. See Bid Specifications Section IV(1), Technical Specifications, Description/Summary.

**RE: Furnish and Deliver Sludge Collection Components for Various Wastewater Treatment Facilities
WW-EQUIP-26-23**

The apparent low bid was submitted by Brentwood Industries, Inc. ("Brentford"). Upon review of the bid submitted by Brentford it was uncovered that the bidder did not submit Insurance Information or Affirmative Action Information within their original bid package. However, the bid specifications provide that the Insurance Information and Affirmative Action Information must be submitted prior to the contract being executed. See Bid Specifications, Section II(XI), General Instruction to Bidders, Statutory and Other Requirements, Mandatory Affirmative Action Certification; See Bid Specifications, Section III, Specific Instructions to Bidders, Insurance Requirements. As such, there are no defects in the bid submitted by Brentwood from a legal perspective.

The bid was further reviewed from a technical perspective by Mr. Joshua Palombo, Wastewater Program Manager on behalf of the Authority. Following his review, via correspondence dated August 9, 2023, Mr. Palombo opined that the bid submitted by Brentford complied with the technical specifications and thereafter recommended the award of the contract to Brentford.

III. LEGAL ANALYSIS

The Local Public Contracts Law, N.J.S.A. 40A:11-1 et seq. regulates bidding on Contracts of public entities in New Jersey. In general, the practice of public bidding is universally recognized and deeply imbedded in the public policy of the State of New Jersey. N.E.R.I. Corp. v. New Jersey Highway Authority, 147 N.J. 223, 236 (1996). There is a prima facie presumption that power and discretion of governmental action in awarding bids on public Contracts has been properly exercised. Colonnelli Bros., Inc. v. Village of Ridgefield Park, 284 N.J.Super. 538, 541 (App.Div.1995).

Public bidding statutes are to be construed with sole reference to the public good and rigidly adhered to by courts. Hall Const. Co., Inc. v. New Jersey Sports & Exposition Authority, 295 N.J.Super. 629, 634 (App.Div.1996). Furthermore, public bidding statutes exist for the good of taxpayers, not bidders, and they must always be construed for the public good and to guard against favoritism, improvidence, extravagance, and corruption. Sevell v. New Jersey Highway Authority, 329 N.J.Super. 580, 584 (App.Div.2000).

Every Contract awarded by the contracting agent for the provision or performance of any goods or services, the cost of which in the aggregate exceeds the bid threshold, shall be awarded only by Resolution of the governing body of the contracting unit to the lowest responsible bidder after public advertising for bids and bidding therefore. N.J.S.A. 40A:11-4. "*Lowest responsible bidder or vendor*" means the bidder or vendor: (a) whose response to a request for bids offers the lowest price and is responsive; and (b) who is responsible. N.J.S.A. 40A:11-2. The lowest responsible bidder on a public Contract must not only be deemed responsible but must submit the lowest bid which conforms to the Contract specifications. Matter of Protest of Award of On-Line Games Production & Operation Services Contract, Bid No. 95-X-20175, 279 N.J.Super. 566, 590 (App.Div.1995).

It is firmly established in New Jersey that material conditions contained in bidding specifications may not be waived. Terminal Const. Corp. v. Atlantic Cty. Sewerage Auth., 67 N.J. 403, 409 (1975). A

RE: Furnish and Deliver Sludge Collection Components for Various Wastewater Treatment Facilities
WW-EQUIP-26-23

contracting body is generally without discretion to accept a defective bid. Meadowbrook Carting Co. v. Borough of Island Heights, 138 N.J. 307, 314 (1994). However, while material conditions contained in bidding specifications may not be waived, this rule does not apply to minor or inconsequential conditions. Public contracting units may resolve problems arising from such conditions in a sensible or practical way. Terminal Const. Corp., 67 N.J. at 409-11. Materiality of a particular specification is to be determined as a matter of law. Hanover Tp. v. Inter. Fidelity Ins. Co., 122 N.J.Super. 544, 548 (App.Div.1973).

There are two (2) criteria for determining whether a specific non-compliance constitutes a substantial and, hence, non-waivable irregularity: (1) Whether the effect of a waiver would be to deprive the public body of its assurance that the Contract will be entered into, performed, and guaranteed according to its specific requirements; and (2) Whether it is of such a nature that its waiver would adversely affect competitive bidding by placing a bidder in a position of advantage over the other bidders or by otherwise undermining the necessary common standard of competition. Township of River Vale v. R.J. Longo Constr. Co., 127 N.J.Super. 207, 222 (Law.Div.1974).

The court has provided further guidance as to materiality where an error is "patent and the true intent of the bidder obvious". In such a situation, the Appellate Division has held that such an error may be disregarded by the public agency. The Court held that certain non-compliance (i.e. obvious error) with the bid specifications may be deemed not material and therefore waivable by the public entity. Spina v. Borough of Fairview, 304 N.J. Super. 425, (App. Div. 1997).

As a matter of law, the Local Public Contract Law requires certain items to be included as material aspects of every bid. The statute reads:

"When required by the bid plans and specifications, the following requirements shall be considered mandatory items to be submitted at the time specified by the contracting unit for the receipt of the bids; the failure to submit any one of the mandatory items shall be deemed a fatal defect that shall render the bid proposal unresponsive and that cannot be cured by the governing body:

- a. A guarantee to accompany the bid pursuant to section 21 of P.L.1971, c.198 (C.40A:11-21);
- b. A certificate from a surety company pursuant to section 22 of P.L.1971, c.198 (C.40A:11-22);
- c. A statement of corporate ownership pursuant to section 1 of P.L.1977, c.33 (C.52:25-24.2);
- d. A listing of subcontractors pursuant to section 16 of P.L.1971, c.198 (C.40A:11-16);
- e. A document provided by the contracting agent in the bid plans, specifications, or bid proposal documents for the bidder to acknowledge the bidder's receipt of any notice or revisions or addenda to the advertisement or bid documents;"

RE: Furnish and Deliver Sludge Collection Components for Various Wastewater Treatment Facilities
WW-EQUIP-26-23

N.J.S.A. 40A:11-23.2.

Finally, a local contracting unit is permitted to reject all bids within a part under certain conditions. N.J.S.A. 40A:11-13.2, provides in pertinent part:

“A local contracting unit can reject all bids for any of the following reasons:

- a. The lowest bid substantially exceeds the cost estimates for the goods or services;
- b. The lowest bid substantially exceeds the contracting unit's appropriation for the goods or services;
- c. The governing body of the contracting unit decides to abandon the project for provision or performance of the goods or services;
- d. The contracting unit wants to substantially revise the specifications for the goods or services;
- e. The purposes or provisions or both of P.L.1971, c. 198 (C.40A:11-1 et seq.) are being violated;
- f. The governing body of the contracting unit decides to use the State authorized contract pursuant to section 12 of P.L.1971, c. 198 (C.40A:11-12).

N.J.S.A. 40A:11-13.2.

As outlined above, there are no apparent defects within the bid submitted by Brentford. To the extent a defect may be uncovered, it is my legal opinion that any such defect is minor in nature and may be waived by the Authority pursuant to the Court's holdings in River Vale and Spina.

IV. BRENTFORD INDUSTRIES, INC.'S BID

My review consisted of an examination of the following documents submitted by Brentford that the Authority has provided:

1. Product Information;
2. Bidder's Checklist;
3. Statement of Ownership Disclosure;
4. Non-Collusion Affidavit;
5. Bid Proposal;
6. Acknowledgment of Receipt of Addenda;
7. Bid Bond;
8. Power of Attorney;
9. Consent of Surety;
10. Surety Disclosure Statement and Certification;

Joseph V. Rizzuto
Executive Director
August 25, 2023
Page 5

RE: Furnish and Deliver Sludge Collection Components for Various Wastewater Treatment Facilities
WW-EQUIP-26-23

11. Surety Financial Statement;
12. Certificate of Authority;
13. New Jersey Business Registration Certificate;
14. Prohibited Russia-Belarus Activities & Iran Investment Activities Form;
15. IRS Form W-9.

The bid submitted by Brentford is in the appropriate form.

V. CONCLUSION

After researching the applicable law, reviewing the Contract specifications and documents, and conferring with staff, it is my legal opinion that the Contract for WW-EQUIP-26-23, to Furnish and Deliver Sludge Collection Components for Various Wastewater Treatment Facilities on behalf of the Authority be awarded to Brentford. Please note that Brentford must supply Insurance Certificate and Affirmative Action Information prior to the execution of an agreement. It is recommended that a Resolution be placed on the Agenda for an upcoming meeting awarding said Contract subject to staff concurrence and the availability of funds.

If you have any questions or require any further clarification, please do not hesitate to contact me.

Very truly yours,
WADE, LONG, WOOD & LONG, L.L.C.

Christopher F. Long

Christopher F. Long, Esquire

cc: Thomas LaRocco, Chief Engineer
Robert Donato, Chief Financial Officer
Kevin Whitney, Senior Advisor
Joshua Palombo, Wastewater Program Manager
Annie M. McDevitt, Office Manager
Kevin McGahey, QPA, Purchasing Agent

Cape May County Municipal Utilities Authority

RESOLUTION NO. 110-23

RESOLUTION AUTHORIZING THE AWARD OF CONTRACT SCF-08-23 – DEMOLITION AND DISPOSAL OF VARIOUS STRUCTURES AND EQUIPMENT AT THE SLUDGE TRANSFER FACILITY TO H4 ENTERPRISES, LLC.

WHEREAS, the Cape May County Municipal Utilities Authority ("CMCMUA"/"Authority") had published an Advertisement for Bids for Contract SCF-08-23 – Demolition and Disposal of Various Structures and Equipment at the Sludge Transfer Facility ("Contract") and furnished detailed Bid Specifications for said Contract to potential Bidders; and,

WHEREAS, the Authority received one (1) Bid in accordance with the Advertisement for Bids for the Contract and publicly opened said Bid on August 15, 2023; and,

WHEREAS, the CMCMUA's Purchasing Agent and Chief Engineer have reviewed the Bid submitted by the sole Bidder, H4 Enterprises, LLC., and have determined that it is a responsive Bid in accordance with the Advertisement for Bids and Bid Specifications for said Contract; and,

WHEREAS, the Authority's General Legal Counsel has reviewed the Bid submitted by H4 Enterprises, LLC. and has opined, after researching the applicable law, that their Bid complies with the Bid Specifications of said Contract; and,

WHEREAS, the Authority's Wastewater Program Manager, Chief Financial Officer, and Executive Director have concurred with said determination; and,

WHEREAS, the Cape May County Municipal Utilities Authority has therefore determined that H4 Enterprises, LLC., P.O. Box 638, 411 Court House South Dennis Road, Cape May Court House, NJ 08210 is the lowest responsible Bidder having submitted a responsive Bid in accordance with the Advertisement for Bids and Bid Specifications for said Contract for a total not-to-exceed amount of \$1,498,847.00; and,

WHEREAS, the Authority's Chief Financial Officer has certified that funds are available for this purpose.

NOW, THEREFORE, BE IT RESOLVED by the Cape May County Municipal Utilities Authority, a body corporate and politic, as follows:

1. The provisions of the WHEREAS clauses set forth above are incorporated herein by reference and made a part hereof.
2. Contract SCF-08-23 identified in the Preamble of this Resolution, in substantially the same form as now on file with the Authority's Office Manager, is hereby awarded to H4 Enterprises, LLC., at the total not-to-exceed amount of \$1,498,847.00.
3. The Authority's Executive Director, or Deputy Director, is hereby authorized and directed to execute said Contract.

	Motion	Second	Yes	No	Abstain	Absent
Mr. Burns						
Ms. Callinan						
Ms. Heenan						
Mr. Matalucci						
Mr. Rixey						
Ms. Saduk						
Mr. Betts						

CERTIFICATION OF FUNDS

I, Robert P. Donato, CPA, Chief Financial Officer of the Cape May County Municipal Utilities Authority, hereby certify that there is currently available in the official budget of the Authority, funds for Contract SCF-08-23 – Demolition and Disposal of Various Structures and Equipment at the Sludge Transfer Facility for a total not-to-exceed amount of \$1,498,847.00 under the line item appropriation or account number(s) 720-0000-751-01-11. These same funds shall not be certified as available for any other contract.

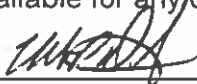

Robert P. Donato, CPA
 Chief Financial Officer

I hereby certify the foregoing to be a true and correct copy of Resolution No. 110-23 adopted by the Cape May County Municipal Utilities Authority at its Regular Meeting on the 6th day of **September 2023**.

 Assistant Corporate Secretary

CAPE MAY COUNTY MUNICIPAL UTILITIES AUTHORITY

CONTRACT FACT SHEET

PROJECT INFORMATION

Project Name: Demolition and Disposal of Various Structures and Equipment at the Sludge Transfer Facility.

Purpose and Scope of Contract: The purpose and scope of this contract is for a vendor to provide labor, superintendence, materials, construction facilities, tools, and equipment necessary for the demolition and disposal, in compliance with Local, State and Federal Regulations, of the Sludge Composting Facility structures (Amendment Storage Building, Operations and Maintenance Building, Bio Reactor-Blower-Cure Reactor, Leachate Storage Tanks, Blower Room No. 2, Cure Pad Duct Bank, Blow Down Tank, Reactor Scrubber, and Composting Storage Structure) and Existing Utilities no longer in use since the fire of 2015.

PROCUREMENT INFORMATION

Contract Type: Procurement (Goods and Services) Professional Services
 Construction Non-Professional Services

Contract Number: SCF-08-23 **Term of Contract:** 210 Calendar Days **Option to Renew:** No Yes:
 from Notice to Proceed Date

Bid Guarantee: No Yes **Consent of Surety:** No Yes

Liquidated Damages: No Yes; 500.00 Per Calendar day after specified date of completion.
 Basis: Potential inability to convey and transfer summer sludge production

Engineer's Estimate: \$4,939,750.00 Contract "A", \$3,627,250.00 Contract "B"

Advertisement Date: June 29, 2023 **Opening Date:** August 15, 2023

Contract Award Basis: Lowest Responsible Bidder Best Value Cooperative Pricing System
 Highest Ranking Score Negotiated

Recommendation: Award: Contract "A"
 Exercise 1 year option to renew under original Contract Terms and Conditions,
 Option Dates: ; Options to Renew remaining:
 Reject, Basis:

CONTRACTOR/VENDOR INFORMATION

Contractor/Vendor: H4 Enterprises LLC **Address:** P.O Box 638
 411 Court House South Dennis Road
 Cape May Court House, N.J. 08210



BUDGET INFORMATION

Program: Wastewater Solid Waste Administration

Funding: Operating Budget Capital SW Building & Site Maintenance SW Equipment Fund

Contract Value, Not-To-Exceed: \$1,498,847.00 Contract "A"

Contract Spending Previous Contract Year: N/A

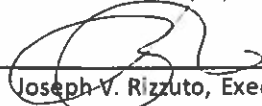
 _____ Kevin W. McGahey, Purchasing Agent	08/31/2023 _____ Date Joshua Palombo, Wastewater Program Manager	8/29/23 _____ Date Robert P. Donato, Chief Financial Officer
 _____ Thomas J. LaRocco, Chief Engineer	08/29/2023 _____ Date	8/31/2023 _____ Date
 _____ Joseph V. Rizzuto, Executive Director	08/24/23 _____ Date	

ENGINEER'S ESTIMATE		OPENING DATE		H4 Enterprises, LLC		
\$4,939,750.00 (Contract A) \$3,627,250.00 (Contract B)		TUESDAY, AUGUST 15, 2023 @ 2:00 P.M.				
CONTRACT NUMBER AND TITLE						
SCF-08-23 Demolition and Disposal of Various Structures and Equipment at the Sludge Transfer Facility						
ITEM	DESCRIPTION	QUANTITY	UNIT PRICE	EXT. PRICE	UNIT PRICE	EXT. PRICE
1	Contract A Mobilization not to exceed 3% of total construction cost, including mobilization	1		33,847.00		
2	Demolition of Amendment Storage Building	1		100,000.00		
3	Demolition of Operation & Maintenance Building	1		180,000.00		
4	Demolition of Bio Reactor-Blower-Cure Reactor	1		500,000.00		
5	Demolition of Leachate Hold Tanks	1		75,000.00		
6	Demolition of Blower No. 2 Building	1		55,000.00		
7	Demolition of Cure Pad Duct Bank	1		50,000.00		
8	Demolition of Blow Down Tank	1		60,000.00		
9	Demolition of Reactor Scrubber	1		115,000.00		
10	Demolition of Composting Storage Structure	1		35,000.00		
11	Demolition of Existing Utilities	1		95,000.00		
12	Allowance for Unforeseen Conditions as set by the Authority \$200,000	1		200,000.00		
(Contract A - TOTAL AMOUNT BID)				\$ 1,498,847.00	\$	\$

WADE, LONG, WOOD & LONG, LLC

Howard C. Long, Jr. †
Daniel H. Long †±◇
Christopher F. Long †◇

John A. Moustakas †◇

John D. Wade †
OF COUNSEL
Leonard J. Wood, Jr. †
OF COUNSEL

† Admitted to NJ Bar
± Admitted to Washington DC Bar
◇ Admitted to PA Bar

August 18, 2023

Joseph V. Rizzuto, Executive Director
CAPE MAY COUNTY MUNICIPAL
UTILITIES AUTHORITY
P.O. Box 610
Cape May Court House, NJ 08210

**RE: Demolition and Disposal of Various Structures at Equipment at the
Sludge Transfer Facility
SCF-08-23**

Dear Mr. Rizzuto:

I. INTRODUCTION

I have reviewed the documents provided regarding the bid submission with respect to the contract for the Demolition and Disposal of Various Structures at Equipment at the Sludge Transfer Facility on behalf of the Cape May County Municipal Utilities Authority (“CMCMUA” and/or “Authority”). The CMCMUA received one (1) bid for this Contract. The bid was received on Tuesday, August 15, 2023, at 2:00 p.m. as follows:

<u>Vendor</u>	<u>Contract A</u>	<u>Contract B</u>
1. H4 Enterprises, LLC	\$1,498,847.00	\$1,498,847.00
<u>Engineer's Estimate</u>	<u>\$4,939,750.00</u>	<u>\$3,627,250.00</u>

II. FACTUAL ANALYSIS

The bid specifications sought a contractor to provide administrative and scheduling personnel, as well as providing all labor, superintendence, materials, construction facilities, tools and equipment necessary and required for properly performing and completing the work See Bid Specifications, Section 01 00 10(1.02), General Requirements, Summary of Work, Work Included. This contract is Phase 2 of a multiphase project of an overall demolition project regarding the decommissioning of the Authority's Seven Mile Beach – Middle Composting Facility. During this phase, the intent is to demolish and dispose of the structures designated, which include the Amendment Storage Building, Operations and Maintenance

**RE: Demolition and Disposal of Various Structures at Equipment at the
Sludge Transfer Facility
SCF-08-23**

Building, Bio Reactor-Blower-Cure Reactor, Leachate Storage Tanks, Blower Room 2, Cure Pad Duct Bridge, Blowdown Building, Reactor Scrubber, in part the Composting Storage Structure, and the Existing Utilities that are no longer in service. See Bid Specifications, Section 01 00 10(1.03), General Requirements, Summary of Work, Summary of Work. The contract was separated into Contract A, and Contract B, with the sole difference between the Contracts being found in Item #4 on the proposal. In Contract A, the proposal was for the Demolition of Bio Reactor-Blower-Cure Reactor, while in Contract B, the proposal was for the Demolition of Bio Reactor-Blower-Cure Reactor Appurtenances only.

The apparent low bidder for the above referenced contract was H4 Enterprises, Inc. ("H4"). Upon examination of the bid submitted by H4, it was uncovered that the bidder did not submit Insurance Certificates within their original bid package. However, the bid specifications provide that Insurance Certificates must be submitted prior to the execution of an agreement. See Bid Specifications Section 00200(34), General Instructions to Bidder, Insurance. As such, all documents submitted by H4 complied with the specifications from a legal perspective.

The bid was further reviewed from a technical perspective by Mr. Joshua Palombo, Wastewater Program Manager, Mr. Thomas LaRocco, Chief Engineer, and Mr. George Hann, Senior Project Engineer on behalf of the Authority. Following their review, via correspondence dated August 16, 2023, Mr. Palombo, Mr. LaRocco, and Mr. Hann opined that the bid submitted by H4 complied with the technical specifications and thereafter recommended the award of Contract A to H4.

III. LEGAL ANALYSIS

The Local Public Contracts Law, N.J.S.A. 40A:11-1 et seq. regulates bidding on Contracts of public entities in New Jersey. In general, the practice of public bidding is universally recognized and deeply imbedded in the public policy of the State of New Jersey. N.E.R.I. Corp. v. New Jersey Highway Authority, 147 N.J. 223, 236 (1996). There is a prima facie presumption that power and discretion of governmental action in awarding bids on public Contracts has been properly exercised. Colonnelli Bros., Inc. v. Village of Ridgefield Park, 284 N.J.Super. 538, 541 (App.Div.1995).

Public bidding statutes are to be construed with sole reference to the public good and rigidly adhered to by courts. Hall Const. Co., Inc. v. New Jersey Sports & Exposition Authority, 295 N.J.Super. 629, 634 (App.Div.1996). Furthermore, public bidding statutes exist for the good of taxpayers, not bidders, and they must always be construed for the public good and to guard against favoritism, improvidence, extravagance, and corruption. Sevell v. New Jersey Highway Authority, 329 N.J.Super. 580, 584 (App.Div.2000).

Every Contract awarded by the contracting agent for the provision or performance of any goods or services, the cost of which in the aggregate exceeds the bid threshold, shall be awarded only by Resolution of the governing body of the contracting unit to the lowest responsible bidder after public advertising for bids and bidding therefore. N.J.S.A. 40A:11-4. "*Lowest responsible bidder or vendor*" means the bidder or vendor: (a) whose response to a request for bids offers the lowest price and is responsive; and (b) who is responsible. N.J.S.A. 40A:11-2. The lowest responsible bidder on a public Contract must not only be

**RE: Demolition and Disposal of Various Structures at Equipment at the
Sludge Transfer Facility
SCF-08-23**

deemed responsible but must submit the lowest bid which conforms to the Contract specifications. Matter of Protest of Award of On-Line Games Production & Operation Services Contract, Bid No. 95-X-20175, 279 N.J.Super. 566, 590 (App.Div.1995).

It is firmly established in New Jersey that material conditions contained in bidding specifications may not be waived. Terminal Const. Corp. v. Atlantic Cty. Sewerage Auth., 67 N.J. 403, 409 (1975). A contracting body is generally without discretion to accept a defective bid. Meadowbrook Carting Co. v. Borough of Island Heights, 138 N.J. 307, 314 (1994). However, while material conditions contained in bidding specifications may not be waived, this rule does not apply to minor or inconsequential conditions. Public contracting units may resolve problems arising from such conditions in a sensible or practical way. Terminal Const. Corp., 67 N.J. at 409-11. Materiality of a particular specification is to be determined as a matter of law. Hanover Tp. v. Inter. Fidelity Ins. Co., 122 N.J.Super. 544, 548 (App.Div.1973).

There are two (2) criteria for determining whether a specific non-compliance constitutes a substantial and, hence, non-waivable irregularity: (1) Whether the effect of a waiver would be to deprive the public body of its assurance that the Contract will be entered into, performed, and guaranteed according to its specific requirements; and (2) Whether it is of such a nature that its waiver would adversely affect competitive bidding by placing a bidder in a position of advantage over the other bidders or by otherwise undermining the necessary common standard of competition. Township of River Vale v. R.J. Longo Constr. Co., 127 N.J.Super. 207, 222 (Law.Div.1974).

The court has provided further guidance as to materiality where an error is “patent and the true intent of the bidder obvious”. In such a situation, the Appellate Division has held that such an error may be disregarded by the public agency. The Court held that certain non-compliance (i.e. obvious error) with the bid specifications may be deemed not material and therefore waivable by the public entity. Spina v. Borough of Fairview, 304 N.J. Super. 425, (App. Div. 1997).

As a matter of law, the Local Public Contract Law requires certain items to be included as material aspects of every bid. The statute reads:

“When required by the bid plans and specifications, the following requirements shall be considered mandatory items to be submitted at the time specified by the contracting unit for the receipt of the bids; the failure to submit any one of the mandatory items shall be deemed a fatal defect that shall render the bid proposal unresponsive and that cannot be cured by the governing body:

- a. A guarantee to accompany the bid pursuant to section 21 of P.L.1971, c.198 (C.40A:11-21);
- b. A certificate from a surety company pursuant to section 22 of P.L.1971, c.198 (C.40A:11-22);

**RE: Demolition and Disposal of Various Structures at Equipment at the
Sludge Transfer Facility
SCF-08-23**

- c. A statement of corporate ownership pursuant to section 1 of P.L.1977, c.33 (C.52:25-24.2);
- d. A listing of subcontractors pursuant to section 16 of P.L.1971, c.198 (C.40A:11-16);
- e. A document provided by the contracting agent in the bid plans, specifications, or bid proposal documents for the bidder to acknowledge the bidder's receipt of any notice or revisions or addenda to the advertisement or bid documents;"

N.J.S.A. 40A:11-23.2

Finally, a local contracting unit is permitted to reject all bids within a part under certain conditions. N.J.S.A. 40A:11-13.2, provides in pertinent part:

"A local contracting unit can reject all bids for any of the following reasons:

- 1. Lowest bid substantially exceeds cost estimates;
- 2. Lowest bid substantially exceeds appropriation;
- 3. Governing body abandons the project;
- 4. Contracting unit wants to substantially revise the bid specifications;
- 5. Purpose and/or provisions of the LPCL and PSCL are violated; or
- 6. Governing body opts to use the state contract."

N.J.S.A. 40A:11-13.2.

As outlined above, there are no apparent defects within the bid submitted by H4. To the extent a defect may be uncovered, it is my legal opinion that any such defect is minor in nature and may be waived by the Authority pursuant to the Court's holdings in River Vale and Spina.

IV. H4 ENTERPRISES, LLC'S BID

My review consisted of an examination of the following documents submitted by H4 that the Authority has provided:

- 1. Bidder's Checklist;
- 2. Bid Bond;
- 3. Surety Disclosure Statement and Certification;
- 4. Surety Financial Statement;
- 5. Power of Attorney;
- 6. Consent of Surety;
- 7. Statement of Ownership Disclosure Form;
- 8. Non-Collusion Affidavit;
- 9. Bidder's Experience/References;
- 10. Performance Record;

**RE: Demolition and Disposal of Various Structures at Equipment at the
Sludge Transfer Facility
SCF-08-23**

11. Mandatory Designation of Subcontractors and/or Bidders Own Workforce Form;
12. Proposal;
13. Acknowledgment of Receipt of Addenda;
14. Prohibited Russia-Belarus Activities & Iran Investment Activities Form;
15. New Jersey Business Registration Certificate;
16. Certification of Non-Debarment for Federal Government Contracts;
17. Public Works Contractor Registration Act Certificate;
18. IRS Form W-9;
19. Certificate of Employee Information Report;
20. Prevailing Wage Certification.

The bid submitted by H4 is in the appropriate form.

V. CONCLUSION

After researching the applicable law, reviewing the Contract specifications and documents, and conferring with staff, it is my legal opinion that Contract A for SCF-08-23, for the Demolition and Disposal of Various Structures at Equipment at the Sludge Transfer Facility on behalf of the Authority be awarded to H4. Please note that H4 must supply insurance certificates prior to the execution of an agreement. It is recommended that a Resolution be placed on the Agenda for an upcoming meeting awarding said Contract subject to staff concurrence and the availability of funds.

If you have any questions or require any further clarification, please do not hesitate to contact me.

Very truly yours,
WADE, LONG, WOOD & LONG, L.L.C.

Christopher F. Long

Christopher F. Long, Esquire

cc: Thomas LaRocco, Chief Engineer
Robert Donato, Chief Financial Officer
Joshua Palombo, Wastewater Program Manager
Kevin Whitney, Senior Advisor
George Hann, Senior Project Engineer
Annie M. McDevitt, Office Manager
Kevin McGahey, Purchasing Agent

Cape May County Municipal Utilities Authority

RESOLUTION NO. 111-23

RESOLUTION AUTHORIZING THE CONTINUATION OF CONTRACT SW-EQUIP-41-22 WITH TURBO SYSTEMS US INC. – FURNISH AND DELIVER OEM REPLACEMENT PARTS, INSPECTIONS AND SHOP SERVICES FOR ABB MODEL TPS-52E01 TURBOCHARGERS PURSUANT TO RESOLUTION NO. 109-22

WHEREAS, on August 3, 2022, the Cape May County Municipal Utilities Authority ("CMCMUA"/"Authority") adopted Resolution No. 109-22 awarding Turbo Systems US Inc. Contract SW-EQUIP-41-22 – Furnish and Deliver OEM Replacement Parts, Inspections and Shop Services for ABB Model TPS-52E01 Turbochargers ("Contract"); and,

WHEREAS, said Contract contains an option provision which would permit the Authority and Turbo Systems US Inc. to continue the Contract, by mutual consent, without change in price, terms or conditions, for two (2) additional 12-month periods; and,

WHEREAS, pursuant to N.J.S.A. 40A:11-15, the Authority is desirous of executing the first 12-month extension of the Contract with Turbo Systems US Inc. without change in price, terms or conditions and, therefore, the Authority wishes to continue the Contract; and,

WHEREAS, compensation to Turbo Systems US Inc. under the continuation of said Contract authorized by this Resolution will be provided based upon the allowances contained in the Proposal submitted on July 19, 2022, by Turbo Systems US Inc., for said Contract (total not-to-exceed amount of \$112,000.00); and,

WHEREAS, the Authority's Chief Financial Officer will certify that funds are available prior to authorizing each Purchase Order for said services.

NOW, THEREFORE, BE IT RESOLVED by the Cape May County Municipal Utilities Authority, a body corporate and politic, as follows:

1. The provisions of the WHEREAS Clauses set forth above are herein incorporated by reference and made a part hereof.
2. The term for Contract SW-EQUIP-41-22 is extended through September 6, 2024.
3. The total not-to-exceed budget of \$112,000.00 for this extended 12-month term for all services provided by Turbo Systems US Inc. under Contract SW-EQUIP-41-22 is based upon the allowances contained in Turbo Systems US Inc.'s Proposal submitted on July 19, 2022, subject to Year 2023 and Year 2024 Solid Waste Management Program Budget appropriations.
4. The Authority's Chief Financial Officer and/or Purchasing Agent are hereby authorized to execute any necessary documents to complete this authorization.

BE IT FURTHER RESOLVED in accordance with N.J.A.C. 5:30-5.5(b)2, no amount for Furnish and Deliver OEM Replacement Parts, Inspections and Shop Services for ABB Model TPS-52E01 Turbochargers under Contract SW-EQUIP-41-22 shall be chargeable or certified until such time as they are actually ordered or otherwise called for. Prior to authorizing any work under this Contract, a certification of available funds shall be made by the Authority's Chief Financial Officer upon receipt of a properly executed Purchase Order and said certification shall be attached to the file copy of the Purchase Order. Total expenditures under this contract shall not exceed \$112,000.00.

	Motion	Second	Yes	No	Abstain	Absent
Mr. Burns						
Ms. Callinan						
Ms. Heenan						
Mr. Matalucci						
Mr. Rixey						
Ms. Saduk						
Mr. Betts						

I hereby certify the foregoing to be a true and correct copy of Resolution No. 111-23 adopted by the Cape May County Municipal Utilities Authority at its Regular Meeting on the 6th day of **September 2023**.

Assistant Corporate Secretary

**CAPE MAY COUNTY MUNICIPAL UTILITIES AUTHORITY
CONTRACT FACT SHEET**

PROJECT INFORMATION

Project Name: Furnish and Deliver OEM Replacement Parts, Inspections and Shop Services for ABB Model TPS-52E01 Turbochargers
Purpose and Scope of Contract: The purpose of this contract is to secure a vendor who will provide, on an as needed basis, workshop overhaul services, as well as, various new and unused original equipment manufacturer's replacement parts and components for the turbochargers installed on the GE Jenbacher landfill gas operated electrical generator sets.

PROCUREMENT INFORMATION

Contract Type: Procurement (Goods and Services) Professional Services
 Construction Non-Professional Services

Contract Number: SW-EQUIP-41-22 **Term of Contract:** One (1) Year **Option to Renew:** No
 Yes: contains Two (2) - One (1) year renewal options

Bid Guarantee: No Yes **Consent of Surety:** No Yes

Liquidated Damages: No Yes: ,Basis:

Engineer's Estimate: \$125,000.00 **Opening Date:** July 19, 2022

Advertisement Date: June 24, 2022

Contract Award Basis: Lowest Responsible Bidder Best Value Cooperative Pricing System
 Highest Ranking Score Negotiated

Recommendation: Award Exercise 1 year option to renew under original Contract Terms and Conditions,
Option Dates: September 7, 2023 through September 6, 2024; Options to Renew remaining: 1
 Reject, Basis:

CONTRACTOR/VENDOR INFORMATION

Contractor/Vendor: Turbo Systems US Inc. **Address:** 26 Worlds Fair Drive
Unit F
Somerset, NJ 08873

BUDGET INFORMATION

Program: Wastewater Solid Waste Administration

Funding:
 Operating Budget Capital SW Building & Site Maintenance SW Equipment Fund

Contract Value, Not-To-Exceed: \$112,000.00

Contract Spending Previous Contract Year: \$7,584.64



Kevin W. McGahey, Purchasing Agent

08-31-2023

Date



John R. Conturo, Solid Waste Program Manager

8/30/2023

Date



Robert P. Donato, Chief Financial Officer

8/31/2023

Date



Joseph V. Rizzuto, Executive Director

08/29/23

Date

Joseph V. Rizzuto, Executive Director

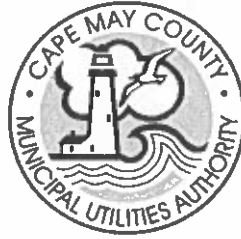

George W. Betts, Chairman
Richard Rixey, Vice Chairman
William G. Burns, Jr.
Patricia A. Callinan
Carol A. Heenan
Zeth Matalucci
Carol L. Saduk

Cape May County Municipal Utilities Authority

1523 Route 9 North, Cape May Court House, NJ 08210
Telephone: (609) 465-9026 • Telefax: (609) 465-9025
www.cmcmua.com

Date: August 23, 2023

Mr. Keith Sanchez
TURBO SYSTEMS US INC.
26 World Fair Drive, Unit F
Somerset, New Jersey 08872

RE: Contract SW-EQUIP-41-22 Furnish and Deliver OEM Replacement Parts, Inspections and Shop Services for ABB Model TPS-52E01 Turbochargers –
RENEWAL 1 of Two (2) One (1) Year Renewal Options

Dear Mr. Sanchez,

The Cape May County Municipal Utilities Authority (CMCMUA) would like to exercise the option to extend Contract SW-EQUIP-41-22 for an additional one (1) year period subject to the same terms and conditions as the original Agreement; a copy of the original contract is attached hereto for your use and reference.

If in concurrence of same Turbo Systems US Inc. will Furnish and Deliver OEM Replacement Parts, Inspections and Shop Services for ABB Model TPS-52E01 Turbochargers, for an additional one (1) year period, from September 7, 2023 through September 6, 2024, at the same terms and conditions as set forth in the original Agreement, dated September 7, 2022, for a total Contract not to exceed amount of \$112,000.00.

Pursuant to New Jersey Public Law 2022, c. 3, "any person or entity that submits a bid or otherwise proposes to enter into or renew a contract..." must complete the enclosed Disclosure of Investment Activities in Iran certification form. Please complete this form and return it with the original signed copy of this letter.

You will also need to update your Affirmative Action documentation and Insurance Certificates with Endorsements. Instructions and sample documentation will be sent under separate cover.

If you have any questions, please do not hesitate to contact me.

Regards,

CAPE MAY COUNTY
MUNICIPAL UTILITIES AUTHORITY



Kevin W. McGahey, QPA
Purchasing Agent

Concur: Yes No

Keith Sanchez (Aug 25, 2023 10:50 EDT)

8/25/23

Signature

Date

Keith Sanchez

Name (Please Print or Type)

KWM:

Attachments: One (1)

c: Mr. John Conturo
Mr. Robert P. Donato
Ms. Ann McDevitt

DISCLOSURE OF INVESTMENT ACTIVITIES IN IRAN

PART I: CERTIFICATION BIDDERS MUST COMPLETE PART I BY CHECKING EITHER BOX FAILURE TO CHECK ONE OF THE BOXES WILL RENDER THE BID NON-RESPONSIVE

Pursuant to Public Law 2012, c. 25, any person or entity that submits a bid or otherwise proposes to enter into or renew a contract must complete the certification below to attest, under penalty of perjury, that the person or entity, or one of the person or entity's parents, subsidiaries, or affiliates, is not identified on a list created and maintained by the Department of the Treasury as a person or entity engaging in investment activities in Iran. The Chapter 25 list is found on the Division's website at <http://www.state.nj.us/treasury/purchase/pdf/Chapter25List.pdf>. Bidders must review this list prior to completing the below certification. Failure to complete the certification will render a bidder's proposal non-responsive. If the Director finds a person or entity to be in violation of the principles which are the subject of this law, s/he shall take action as may be appropriate and provided by law, rule or contract, including but not limited to, imposing sanctions, seeking compliance, recovering damages, declaring the party in default and seeking debarment or suspension of the person or entity.

PLEASE CHECK THE APPROPRIATE BOX

I certify, pursuant to Public Law 2012, c. 25 that neither the bidder listed below nor any of the bidder's parents, subsidiaries, or affiliates is listed on the N.J. Department of the Treasury's list of entities determined to be engaged in prohibited activities in Iran pursuant to P.L. 2012, c. 25 ("Chapter 25 List"). I further certify that I am the person listed below, or I am an officer or representative of the entity listed below and am authorized to make this certification on its behalf. I will skip Part 2 and sign and complete the Certification below.

OR

I am unable to certify as above because the bidder and/or one or more of its parents, subsidiaries, or affiliates is listed on the Department's Chapter 25 list. I will provide a detailed, accurate and precise description of the activities in Part 2 below and sign and complete the certification below. Failure to provide such will result in the bid being rendered as non-responsive and appropriate penalties, fines and/or sanction will be assessed as provide by law.

PART 2: PLEASE PROVIDE FURTHER INFORMATION RELATED TO INVESTMENT ACTIVITIES IN IRAN

You must provide, accurate and precise description of the activities of the bidding person/entity, or one of its parents, subsidiaries or affiliates, engaging in the investment activities in Iran outlined above by completing the boxes below.

NAME: _____	Relationship to Bidder _____
Description of Activities _____	
Duration of Engagement _____	Anticipated Cessation Date: _____
Bidder Contact Name _____	Contact Phone Number _____

Certification: I, being duly sworn upon my oath, hereby represent and state that the foregoing information and any attachments thereto to the best of my knowledge are true and complete. I attest that I am authorized to execute this certification on behalf of the above-referenced person or entity. I acknowledge that the Cape May County Municipal Utilities Authority ("CMCMUA") is relying on the information contained herein and thereby acknowledge that I am under a continuing obligation from the date of this certification through the completion of any contracts with the CMCMUA to notify the CMCMUA in writing of any changes to the answers of information contained herein. I acknowledge that I am aware that it is a criminal offense to make a false statement or misrepresentation in this certification, and if I do so, I recognize that I am subject to criminal prosecution under the law and that it will also constitute a material breach of my agreement(s) with the CMCMUA and that the CMCMUA at its option may declare any contract(s) resulting from this certification void and unenforceable.

Name of Bidder (Company): Turbo Systems US Inc
Full Name (Print): Keith Sanchez Signature:  (Aug 25, 2023 10:50 EDT)
Title: Account Manager Date: 8/25/23







SW-EQUIP-41-22-RENEWAL 1 - letter of concurrence complete- Turbo Systems US - fillable

Final Audit Report

2023-08-25

Created:	2023-08-23
By:	Kevin McGahey (mccaheykw@cmcmua.com)
Status:	Signed
Transaction ID:	CBJCHBCAABAAzayCNcWMLxOyaG2JZdyf5ldhAAeC86FN

"SW-EQUIP-41-22-RENEWAL 1 - letter of concurrence complete- Turbo Systems US - fillable" History

-  Document created by Kevin McGahey (mccaheykw@cmcmua.com)
2023-08-23 - 8:08:51 PM GMT- IP address: 108.11.5.202
-  Document emailed to keith.sanchez@accelleron-industries.com for signature
2023-08-23 - 8:09:28 PM GMT
-  Email viewed by keith.sanchez@accelleron-industries.com
2023-08-25 - 2:44:19 PM GMT- IP address: 104.47.22.62
-  Signer keith.sanchez@accelleron-industries.com entered name at signing as Keith Sanchez
2023-08-25 - 2:50:46 PM GMT- IP address: 136.226.80.115
-  Document e-signed by Keith Sanchez (keith.sanchez@accelleron-industries.com)
Signature Date: 2023-08-25 - 2:50:48 PM GMT - Time Source: server- IP address: 136.226.80.115
-  Agreement completed.
2023-08-25 - 2:50:48 PM GMT



Adobe Acrobat Sign

Cape May County Municipal Utilities Authority

RESOLUTION NO. 112-23

RESOLUTION DESIGNATING SOLID WASTE MANAGEMENT PROGRAM
2021 EXCESS REVENUES

WHEREAS, through Resolution No. 160-21, the Cape May County Municipal Utilities Authority ("CMCMUA"/"Authority") designated excess revenues after providing for the additional expenditures from the 2021 Solid Waste Management Program Operations Budget be transferred into a Future Construction Reserve Fund; and

WHEREAS, on March 1, 2023, the CMCMUA's Auditor, Ford-Scott & Associates, LLC, explained certain aspects of the "Report on Audit of Basic Financial Statements and Supplemental Information Years Ended December 31, 2021 and 2020" ("2021 Audit") and responded to questions raised by Authority Members pertaining to the 2021 Audit; and

WHEREAS, through Resolution 26-23, the Authority Members certified personal review of the 2021 Audit; and

WHEREAS, in light of the developments in the recycling industry, recycling commodity markets, projected costs to process Cape May County recyclables in 2024, and through prudent financial planning and budgeting, the Authority endorses the transfer of one million six hundred sixty three thousand five hundred seventy seven dollars (\$1,663,577) of 2021 Solid Waste Management Program excess revenues, as indicated in Schedule 6 of the 2021 Audit, from the Future Construction Reserve Fund to the Intermediate Processing Facility Rate Stabilization Fund to partially subsidize the total cost associated with processing Cape May County recyclables in 2024.

NOW, THEREFORE, BE IT RESOLVED by the Cape May County Municipal Utilities Authority, a body corporate and politic, as follows:

1. The provisions of the WHEREAS clauses set forth above are incorporated herein by reference and made a part hereof.
2. The Cape May County Municipal Utilities Authority hereby authorizes its Chief Financial Officer to transfer one million six hundred sixty three thousand five hundred seventy seven dollars (\$1,663,577) of 2021 Solid Waste Management Program excess revenue of two million four hundred thirteen thousand five hundred seventy seven dollars (\$2,413,577) from the Solid Waste Management Program's Future Construction Reserve Fund to the Solid Waste Management Program's Intermediate Processing Facility Rate Stabilization Fund.

	Motion	Second	Yes	No	Abstain	Absent
Mr. Burns						
Ms. Callinan						
Ms. Heenan						
Mr. Matalucci						
Mr. Rixey						
Ms. Saduk						
Mr. Betts						

I hereby certify the foregoing to be a true and correct copy of Resolution No. 112-23 adopted by the Cape May County Municipal Utilities Authority at its Regular Meeting on the 6th day of September 2023.

Assistant Corporate Secretary

MEMORANDUM

TO: CMCMUA AUTHORITY MEMBERS
FROM: Joseph V. Rizzuto, Executive Director 
DATE: September 1, 2023
RE: Designation of Solid Waste Management Program 2021 Excess Revenues

Commencing in 2022, the Authority has been under Agreement with Omni Recycling Group, LLC to transport and process Cape May County generated Recyclables at Omni's facility located in Pitman, New Jersey. Initially, the Agreement was for one-year with a fee of \$550.00 per truck to transport Recyclables and a processing fee of \$30.00 per ton of Recyclables for a total Agreement value of \$2,275,000. Based upon cost and revenue projections on the one-year Agreement with Omni, along with recycling industry indicators, the Authority deemed the most cost-effective path to process Recyclables in the year 2023 was to enter into negotiations with Omni to leverage unrealized projected revenue from the sale of Recyclables to extend the Agreement with Omni through the year 2023. The Authority and Omni came to terms on an amended Agreement, which was authorized by the CMCMUA Board of Commissioners on June 29, 2022. As a result of negotiations, the CMCMUA agreed to eliminate the provision to share a percentage of revenue from the sale of Recyclables for a combined transportation and processing fee of zero dollars (\$0.00) and \$55.00 dollars for the years 2022 and 2023, respectively. The total amended Agreement value was \$1,650,000.00 with an expiration date of December 31, 2023.

The source of funds to compensate Omni under the terms and conditions of the Agreement to process Recyclables in the year 2023 has been the IPF Rate Stabilization Fund. To continue to subsidize the costs associated with processing Recyclables in 2024 through the IPF Rate Stabilization Fund, I analyzed the following: projected costs to process Recyclables generated in the months of August through December 2023; the projected balance of the IPF Rate Stabilization Fund upon payment of all 2023 invoices; and the projected total cost to process Recyclables in 2024 utilizing a proposed 2024 per ton processing fee and projected total 2024 Recyclable tonnages.

Based upon the aforementioned, to continue to subsidize the costs associated with processing Cape May County generated Recyclables in 2024 through the IPF Rate Stabilization Fund, it is recommended that the Authority Members consider adopting a Resolution at the September 6, 2023 Board Meeting endorsing the transfer of one million six hundred sixty three thousand five hundred seventy seven dollars (\$1,663,577,000) of 2021 Solid Waste Management Program excess revenues of two million four hundred thirteen thousand five hundred seventy seven dollars (\$2,413,577), as indicated in Schedule 6 of the 2021 Audit, from the Future Construction Reserve Fund to the Intermediate Processing Facility Rate Stabilization Fund.

cc: Thomas J. LaRocco, P.E., Chief Engineer
John R. Conturo, P.E., Solid Waste Program Manager
Robert P. Donato, C.P.A., Chief Financial Officer
Ann McDevitt, Office Manager

Cape May County Municipal Utilities Authority

RESOLUTION NO. 113-23

RESOLUTION AUTHORIZING THE EXECUTION OF AGREEMENT FOR SOLID WASTE HOST COMMUNITY BENEFITS TO BE PROVIDED TO THE TOWNSHIP OF MIDDLE

WHEREAS, the New Jersey Solid Waste Management Act (N.J.S.A. 13:1E-1 et seq.) ("Act") empowers the Cape May County Board of Chosen Freeholders to adopt a Solid Waste Management Plan ("Plan") for Cape May County; and,

WHEREAS, the Cape May County Board of Chosen Freeholders has previously adopted and subsequently amended a Solid Waste Management Plan for Cape May County pursuant to the New Jersey Solid Waste Management Act; and,

WHEREAS, the New Jersey Department of Environmental Protection ("NJDEP") has approved the previously adopted Cape May County Solid Waste Management Plan and subsequent amendments pursuant to the Act; and,

WHEREAS, the Cape May County Board of Chosen Freeholders has designated the Cape May County Municipal Utilities Authority ("CMCMUA/Authority") as the implementing agency for said Plan; and,

WHEREAS, pursuant to the Plan, the CMCMUA has constructed and conducts various solid waste activities at a site located in the Township of Middle, in Cape May County, New Jersey (hereinafter referred to as the "Solid Waste Transfer Station"); and,

WHEREAS, the Township of Middle is, therefore, a "host community" via said location of the Authority's Transfer Station being within its boundaries; and,

WHEREAS, New Jersey law provides that a municipality within which an approved solid waste facility is located shall be entitled to an annual economic benefit in consideration of the amount of solid waste accepted at such a facility; and,

WHEREAS, the Authority's Solid Waste Transfer Station is such a State-approved solid waste facility; and,

WHEREAS, the parties desire to enter into a "Host Community Benefit" Agreement which sets forth the economic benefit to be paid to the Township of Middle by the Authority as a result of specified solid waste activities related to the Authority's Solid Waste Transfer Station; and,

WHEREAS, the Authority and the Township of Middle have negotiated the provisions of an Agreement setting forth the terms and compensation to be provided to the Township of Middle as a Host Community for the Authority's Solid Waste Transfer Station; and,

WHEREAS, the Authority's Executive Director has recommended approval of a proposed Agreement; and,

WHEREAS, the Township of Middle has approved the proposed Agreement.

NOW, THEREFORE, BE IT RESOLVED by the Cape May County Municipal Utilities Authority, a body corporate and politic, as follows:

1. The Authority's Executive Director, or Deputy Director, is hereby authorized to execute an Agreement with the Township of Middle, in substantially the same form as that now on file with the Authority's Office Manager, to formalize the terms and economic benefit to said municipality, to be known as a "Host Community Benefit".
2. Execution of said Agreement supersedes all prior Agreements between the Township of Middle and the Cape May County Municipal Utilities Authority with respect to the host community benefits.
3. The term of said contract is for five (5) years commencing January 1, 2024, unless such date is extended by mutual agreement of the parties.

	Motion	Second	Yes	No	Abstain	Absent
Mr. Burns						
Ms. Callinan						
Ms. Heenan						
Mr. Matalucci						
Mr. Rixey						
Ms. Saduk						
Mr. Betts						

I hereby certify the foregoing to be a true and correct copy of Resolution No. 113-23 adopted by the Cape May County Municipal Utilities Authority at its Regular Meeting on the 6th day of **September 2023**.

Assistant Corporate Secretary

MEMORANDUM

TO: CMCMUA Board of Commissioners

FROM: Joseph V. Rizzuto, Executive Director

DATE: August 29, 2023

RE: Recommendation Regarding Host Community Benefit Agreement – Township of Middle

New Jersey Statute provides that a municipality within which an approved solid waste facility is located shall be entitled to an annual economic benefit in consideration of the amount of solid waste accepted for transfer or disposal. The Authority has been providing an equal host community benefit to the Township of Upper and the Borough of Woodbine in the case of the Secure Sanitary Landfill located on the border of the two municipalities. Additionally, the Authority has been providing a host community benefit to the Township of Middle in the case of the Solid Waste Transfer Station located in Burleigh. The terms of the host community benefit provided to each municipality is set forth in the respective Host Community Benefit Agreements ("Agreement"). The Agreement with the Township of Middle expires on December 31, 2023.

Through correspondence dated July 10, 2023, I proposed, in accordance with Section III of the Agreement, to extend, subject to the same terms and conditions and upon consent of the Township of Middle, the Agreement term for another five (5) years, from January 1, 2024 through December 31, 2028. I am pleased to report that the Township of Middle Committee approved the Agreement, as presented in the July 10, 2023 correspondence, at their August 7, 2023 meeting.

A summary of the terms of the Agreement are as follows: the host community benefit will be \$2.03/ton each year of the Agreement for solid waste disposed of at the Transfer Station; and, if in any calendar year during the term of the Agreement, the total solid waste accepted for disposal at the Secure Sanitary Landfill exceeds 160,000 tons, including the solid waste tons received from the Transfer Station, an additional fee of \$1.00 per ton will be paid.

Therefore, I recommend that the Authority take formal action to approve and authorize execution of the attached Host Community Benefit Agreement with the Township of Middle at the September 6, 2023 Board Meeting.

HOST COMMUNITY BENEFIT AGREEMENT

THIS AGREEMENT made this _____ day of _____, 2023, between:

THE CAPE MAY COUNTY MUNICIPAL UTILITIES AUTHORITY, a public body politic and corporate, constituting a political subdivision of the State of New Jersey, with principal offices at 1523 Route 9 North, Cape May Court House, New Jersey 08210, hereinafter also referred to as "CMCMUA";

and

THE TOWNSHIP OF MIDDLE, a municipal corporation of the State of New Jersey, with principal offices at 33 Mechanic Street, Cape May Court House, New Jersey 08210, hereinafter also referred to as "Middle Township";

WHEREAS, the CMCMUA operates a solid waste transfer station ("Transfer Station") located at 650 Shunpike Road, in Middle Township, in Cape May County, New Jersey; and

WHEREAS, said Transfer Station has been sited at said location pursuant to the "*Cape May County Solid Waste Management Plan*", as amended and adopted by the Cape May County Board of County Commissioners and approved by the New Jersey Department of Environmental Protection; and

WHEREAS, Middle Township is the host community for said Transfer Station; and

WHEREAS, New Jersey Statute, N.J.S.A. 13:1E-28.1, provides that a municipality within which an approved solid waste facility is located shall be entitled to an annual economic benefit in consideration of the amount of solid waste accepted for transfer at said facility; and

WHEREAS, pursuant to said Statute, the CMCMUA has provided, and continues to provide, an economic benefit to Middle Township based upon the quantity of solid waste accepted at the CMCMUA's Transfer Station in Middle Township for transfer and off-site disposal; and

WHEREAS, the CMCMUA and Middle Township now wish to enter into a formal Agreement setting forth the total economic benefit to be paid to Middle Township by the CMCMUA as a result of specified solid waste activities related to the CMCMUA's Transfer Station.

NOW, THEREFORE, in consideration of the promises and of the mutual obligations undertaken herein, the parties agree as follows:

I. Economic Benefit to Middle Township for Solid Waste Accepted for Transfer and Off-Site Disposal

The CMCMUA shall pay to Middle Township a per ton economic benefit, as set forth in Sub-Paragraph A. and B. below, on all solid waste generated within Cape May County that is accepted at the CMCMUA's Transfer Station located in Middle Township for the purpose of transfer and off-site disposal.

A. Economic Benefit

The economic benefit for solid waste transfer, by or on behalf of the CMCMUA, for the purpose of off-site disposal shall be payable as follows:

ECONOMIC BENEFIT

\$2.03 per ton

- B.** If, in any calendar year during the term of this Agreement, the total solid waste accepted for disposal at the CMCMUA's Sanitary Landfill exceeds 160,000 tons, including the solid waste tons received from Transfer Station, an additional fee of \$1.00 per ton will be paid.

II. Limitation on Economic Benefits to be Provided

Notwithstanding any provisions of this Agreement to the contrary, the economic benefits set forth in this Agreement shall only be payable to Middle Township by the CMCMUA: (1) during the term of this Agreement; and (2) only during such time as the County of Cape May and/or the CMCMUA retain enforceable legal authority to direct all solid waste generated within the County of Cape May, which is not disposed of at an out-of-State solid waste disposal facility, to be delivered to the CMCMUA's solid waste complex for processing and/or disposal (i.e., "Intra-State Waste Flow Control Authority").

In the event that such Intra-State Waste Flow Control Authority shall be invalidated and/or rescinded, the CMCMUA shall have the right to reduce the economic benefit provided to Middle Township consistent with the applicable prevailing statutory minimum established pursuant to New Jersey State Statute.

III. Term

This Agreement shall be effective January 1, 2024 and shall terminate on December 31, 2028. The Term of this Agreement may be extended by up to five (5) additional years (single or multiple year extensions) upon mutual agreement of the parties.

IV. Definition of "Solid Waste"

"Solid Waste", as used in this Agreement, shall not include source separated recyclable materials delivered to the CMCMUA's Transfer Station, which includes but is not limited to, ferrous and non-ferrous metals, mixed colored glass containers and plastic containers, mixed paper, and/or tires, wood, wood pallets, and white goods.

V. Time and Method of Payment of Economic Benefit

The economic benefits to be paid to Middle Township by the CMCMUA pursuant to the provisions of this Agreement shall be credited to Middle Township's solid waste account, as maintained by the CMCMUA, on a quarterly basis.

VI. Parties Bound

This Agreement shall be binding upon the parties hereto and their legal successors

VII. Representations

A. Necessary Action

The CCMUA and Middle Township each represent that all necessary actions have been taken to authorize the signing of this Agreement by the respective parties.

B. Extension/Modification

The parties represent that they shall commence negotiations on or about July 1, 2028 with respect to extending the term of this Agreement or any other modification thereof.

VIII. Entire Understanding

This Agreement contains the entire understanding between the parties and supersedes, in their entirety, all previous agreements between them regarding economic benefits, whether oral or in writing. This Agreement cannot be modified or terminated except in accordance with its terms or by a subsequent written agreement signed by both parties.

IN WITNESS WHEREOF, the parties hereto have set their hands and seals this 9th day of August, 2023.

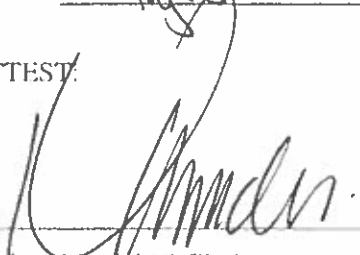
ATTEST:

Municipal Clerk

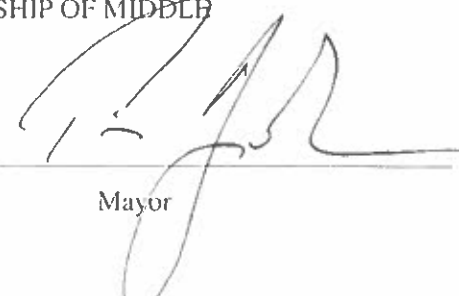
TOWNSHIP OF MIDDLEBURY
By: 

Mayor

ATTEST:

Anne M. McDevitt
Asst. Corporate Secretary

CAPE MAY COUNTY
MUNICIPAL UTILITIES AUTHORITY
By: _____
Joseph V. Rizzuto
Executive Director

TOWNSHIP OF MIDDLE
COUNTY OF CAPE MAY
STATE OF NEW JERSEY

RESOLUTION
347-23

Date: August 7, 2023

Subject: RATIFY AGREEMENT BETWEEN THE TOWNSHIP OF MIDDLE AND CAPE MAY COUNTY MUNICIPAL UTILITIES AUTHORITY

Introduced By: Committeeman Gandy Seconded By: Committeeman Norris

Vote – Aye: Committeeman Gandy, Committeeman Norris, Mayor Donohue

Nay:

NOW THEREFORE BE IT RESOLVED, by the Township Committee, the Governing Body of the Township of Middle, County of Cape May and State of New Jersey, that the agreement between the Township of Middle and the Cape May County Municipal Utilities Authority for economic benefit towards the solid waste transfer station located in Middle Township, as attached, for a term effective January 1, 2024 through December 31, 2028, is hereby ratified.

BE IT FURTHER SOLVED, that the appropriate officials are hereby authorized to sign said agreement in connection therewith.

I, Kimberly D. Osmundsen, Township Clerk of the Township of Middle, Cape May County, do hereby certify the foregoing to be a true and correct copy of a Resolution adopted by the Township Committee at a meeting of said Middle Township Committee, held on August 7, 2023 and said Resolution was adopted by no less than a two-thirds vote of the members of the Township Committee.

Witness my hand and seal of
the Township of Middle, this
7th day of August, 2023



Kimberly D. Osmundsen, Township Clerk

Cape May County Municipal Utilities Authority

RESOLUTION NO. 114-23

RESOLUTION AUTHORIZING THE RENEWAL OF MEMBERSHIP IN THE NEW JERSEY UTILITY AUTHORITIES JOINT INSURANCE FUND

WHEREAS, the New Jersey Utilities Authorities Joint Insurance Fund ("Fund") is a duly chartered Municipal Insurance Fund as authorized by N.J.S.A. 40A:10-36 et seq.; and,

WHEREAS, the Cape May County Municipal Utilities Authority ("Authority") is currently a member of the Fund; and,

WHEREAS, said membership terminates as of December 31, 2023 unless earlier renewed by Agreement between the Authority and the Fund; and,

WHEREAS, the Authority desires to renew said membership.

NOW, THEREFORE, BE IT RESOLVED by the Cape May County Municipal Utilities Authority, a body corporate and politic, as follows:

- 1. The provisions of the WHEREAS Clauses set forth above are incorporated herein by reference and made a part of hereof.
2. The Cape May County Municipal Utilities Authority hereby agrees to renew its membership in the New Jersey Utility Authorities Joint Insurance Fund for a three (3) year period, beginning January 1, 2024 and ending January 1, 2027 at 12:01 am.
3. The Cape May County Municipal Utilities Authority hereby agrees to renew its membership in the New Jersey Utility Authorities Joint Insurance Fund and to be subject to the Bylaws, Rules and Regulations, coverages, and operating procedures thereof as presently existing or as modified from time to time by lawful act of the Fund.
4. The Authority's Executive Director, or Deputy Director, is hereby authorized to execute the Agreement to renew membership annexed hereto and made a part hereof and to deliver same to the New Jersey Utility Authorities Joint Insurance Fund evidencing the Authority's intention to renew its membership.

Table with 7 columns: Motion, Second, Yes, No, Abstain, Absent and 7 rows of names: Mr. Burns, Ms. Callinan, Ms. Heenan, Mr. Matalucci, Mr. Rixey, Ms. Saduk, Mr. Betts.

I hereby certify the foregoing to be a true and correct copy of Resolution No. 114-23 adopted by the Cape May County Municipal Utilities Authority at its Regular Meeting on the 6th day of September 2023.

Assistant Corporate Secretary

MEMORANDUM

September 1, 2023

TO: CMCMUA AUTHORITY MEMBERS

FROM: Joseph V. Rizzuto, Executive Director 

RE: New Jersey Utility Authorities Joint Insurance Fund Membership Renewal

The Cape May County Municipal Utilities Authority has been a member of the New Jersey Utility Authorities Joint Insurance Fund (JIF) since March of 1994. The CMCMUA's current membership expires on December 31, 2023, therefore in order to maintain membership in the JIF, the Authority is required to adopt a renewal membership Resolution for an additional three (3) year period, commencing January 1, 2024.

Membership in the New Jersey Utility Authorities Joint Insurance Fund has proven to be extremely beneficial to the CMCMUA through access to the largest municipal property-casualty pool in the country, expanded coverages, reduced deductibles through the JIF's Employment Practices Compliance Program, and a zero-deductible for full compliance with the JIF's cybersecurity framework. Membership includes insurance coverage for Property, Liability, Worker's Compensation, Public Officials/Employee Practices Liability, Environmental Damages, and Cyber/Technology Liability through the formation of a Cyber JIF.

Our current membership costs, for the three-year period ending December 31, 2023 were: 2021: \$938,403; 2022: \$1,004,762; and 2023: \$1,104,506.

The JIF's assessment for the year 2024 will not be known until they adopt their budget in November. Increased costs in Workers' Compensation associated with recent court and state decisions, the high cost of cyber incidents and claims, and increases in property insurance rates due to natural disasters have been the noted major drivers in the increase in membership costs over the three years. While the total cost for the Authority's insurance coverage represents a large expenditure, as a single client in today's commercial insurance market, the CMCMUA would potentially incur even higher insurance costs.

In view of the above, as well as the JIF's responsiveness in handling CMCMUA claims and the loss prevention programs offered by the JIF, I recommend that the CMCMUA renew its membership in the New Jersey Utility Authorities Joint Insurance Fund for a three (3) year period beginning January 1, 2024 and ending January 1, 2027 at 12:01 a.m..

It is requested that the above-noted recommendation be considered for approval and the attached proposed Resolution be adopted at the CMCMUA's Regular Meeting of September 6, 2023.

JVR:jvr

New Jersey Utility Authorities Joint Insurance Fund

9 Campus Drive, Suite 216
Parsippany, NJ 07054-4412
Telephone (201) 881-7632 Fax (201) 881-7633
www.njuajif.org

August 3, 2023

Bradley Rosenthal
Fund Commissioner
Cape May County Municipal Utilities Authority
1523 Route 9 South
Cape May Courthouse, NJ 08210

Re: Resolution to Renew Membership
Agreements to Renew Membership

Dear Bradley Rosenthal,

Your authority's membership in the New Jersey Utility Authorities Joint Insurance Fund expires on December 31, 2023. To maintain your membership, your governing body needs to adopt a renewal membership resolution and execute the enclosed indemnity & trust agreement for an additional three years.

2023 is the New Jersey Utility Authorities Joint Insurance Fund 32nd year of operation. During that time, the NJUA JIF has grown from 17 charter members to its current membership of 74 authorities. The NJUA JIF has become a very successful joint insurance fund and is in a very strong financial position.

As of March 31, 2023, the NJUA JIF has earned \$28,927,001 in surplus, representing 12% of the total assessments collected. While the Fund is required to retain a surplus in accordance with regulations promulgated by the Department of Banking & Insurance, the Fund has been able to return \$26,178,060 of that surplus in dividends to its members.

Since its inception, the Fund has expanded its coverages to include public officials and employment practices liability, crime coverage, environmental impairment liability and cyber liability.

We would be glad to provide any information you would like about the Fund to assist you in your decision to renew your membership. Additionally, we would be more than happy to meet with you or your governing body to discuss your continued membership.

Enclosed you will find the Resolution to Renew and Agreement to Renew. Please execute these documents and return to the Fund office by October 2, 2023.

Thank you for your attention to this matter.

Sincerely,
NEW JERSEY UTILITY AUTHORITIES JOINT INSURANCE FUND

Cathleen Kiernan

Cathleen Kiernan, Executive Director
Perma Risk Management Services

cc: Jennifer Modica, Risk Manager

**AGREEMENT TO RENEW MEMBERSHIP IN THE
NEW JERSEY UTILITY AUTHORITIES JOINT INSURANCE FUND**

WHEREAS, the New Jersey Utility Authorities Joint Insurance Fund (hereinafter the Fund) is a duly chartered Municipal Insurance Fund as authorized by NJSA 40A:10-36 et seq., and;

WHEREAS, the Cape May County Utilities Authority is currently a member of said Fund, and;

WHEREAS, effective December 31, 2023, said membership will expire unless earlier renewed, and;

WHEREAS, the Governing Body of the Cape May County Utilities Authority has resolved to renew said membership;

NOW THEREFORE, it is agreed as follows:

1. Cape May County Utilities Authority hereby renews its membership in the New Jersey Utility Authorities Joint Insurance Fund for a three (3) year period, beginning January 1, 2024 and ending January 1, 2027.*
2. The Cape May County Utilities Authority hereby ratifies and reaffirms the Indemnity and Trust Agreement, Bylaws and other organizational and operational documents of the New Jersey Utility Authorities Joint Insurance Fund as from time to time amended and altered by the Department of Insurance in accordance with the Applicable Statutes and administrative regulations as if each and every one of said documents were re-executed contemporaneously herewith.
3. The Cape May County Utilities Authority agrees to be a participating member of the Fund for the period herein provided for and to comply with all of the rules and regulations and obligations associated with said membership.
4. In consideration of the continuing membership of the Cape May County Utilities Authority in the New Jersey Utility Authorities Joint Insurance Fund, the New Jersey Utility Authorities Joint Insurance Fund agrees, subject to the continuing approval of the Commissioner of Banking & Insurance, to accept the renewal application of the Cape May County Utilities Authority.
5. Executed the _____ day of _____, 2023 as the lawful and binding act and deed of the Cape May County Municipal Utilities Authority, which execution has been duly authorized by public vote of the governing body.

*12:01 am

Cape May County Municipal Utilities Authority

RESOLUTION NO. 115-23

RESOLUTION AUTHORIZING AND DELEGATING THE CAPE MAY COUNTY MUNICIPAL UTILITIES AUTHORITY'S QUALIFIED PURCHASING AGENT THE ABILITY TO AWARD CONTRACTS HAVING AN ANTICIPATED VALUE IN EXCESS OF \$17,500 BUT BELOW THE INCREASED BID THRESHOLD PURSUANT TO N.J.S.A 19:44A-20.4

WHEREAS, through Resolution No. 96-20, Kevin W. McGahey was appointed as the Qualified Purchasing Agent ("QPA") and was authorized to exercise the duties of a QPA on behalf the Cape May County Municipal Utilities Authority ("CMCMUA" and/or "Authority") effective August 3, 2020; and,

WHEREAS, N.J.S.A. 40A:11-1 et seq., the Local Public Contracts Law, permits a contracting agency that appoints a QPA a higher bid threshold, as well as grants the QPA authorization to negotiate and award such contracts below the bid threshold; and,

WHEREAS, the CMCMUA wishes to continue to take advantage of the higher bid and quote thresholds in accordance with N.J.S.A. 40A:11-3 and N.J.S.A. 40A:11-6.1(a); and,

WHEREAS, P.L. 2023, c. 30, known as the "Elections Transparency Act," ("Act") made various significant changes to New Jersey's pay-to-play laws, as well as changes relevant to local government pursuant to N.J.S.A. 19:44A-20.4 and 20.5; and,

WHEREAS, Sections 11 and 12 of the Act amend N.J.S.A. 19:44A-20.4 and 20.5, respectively, to clarify that the governing body of a municipality or county [or any agency or instrumentality thereof] may delegate the authority to award a contract having an anticipated value in excess of \$17,500 but below the increased bid threshold of a Local Public Contracts Law contracting unit with a QPA [i.e. a "window contract"] to the QPA.

NOW, THEREFORE, BE IT RESOLVED, the Board of Commissioners of the Cape May County Municipal Utilities Authority hereby authorizes and delegates the Cape May County Municipal Utilities Authority's Qualified Purchasing Agent the ability to award contracts having an anticipated value in excess of \$17,500 but below the increased bid threshold pursuant to N.J.S.A 19:44A-20.4.

BE IT FURTHER RESOLVED, that the Cape May County Municipal Utilities Authority shall forward a certified copy of this Resolution to the Director of the Division of Local Government Services.

	Motion	Second	Yes	No	Abstain	Absent
Mr. Burns						
Ms. Callinan						
Ms. Heenan						
Mr. Matalucci						
Mr. Rixey						
Ms. Saduk						
Mr. Betts						

I hereby certify the foregoing to be a true and correct copy of Resolution No. 115-23 adopted by the Cape May County Municipal Utilities Authority at its Regular Meeting on the 6th day of September 2023.

Assistant Corporate Secretary

P.O. Type: All
 Range: First to Last
 Format: Condensed
 Vendors: All
 Rcvd Batch Id Range: First to Last

Open: N
 Rcvd: N
 Bid: Y
 State: Y
 Other: Y
 Exempt: Y

Paid Date Range: 08/17/23 to 09/06/23
 Include Non-Budgeted: Y
 Prior Year Only: N

PO #	PO Date	Vendor	PO Description	Status	Amount	Void Amount	PO Type
M2300111	01/11/23	CASAP005	CASA PAYROLL SERVICE	Payroll Services Contract 1 Yr	Open	312.00	0.00
M2300114	01/11/23	WASTE045	WASTE MANAGEMENT OF NJ, INC.	TRASH DISPOSAL SERVICES	Open	73.36	0.00
M2300121	01/11/23	SUPPR005	SUPPRESSION SYSTEMS, INC.	INSPECTION AGREEMENT RENEWAL	Open	1,315.00	0.00
M2300136	01/13/23	ATLAN205	ATLANTICARE PHYSICIAN GROUP	DOT CDL ReCertification Exams	Open	200.00	0.00
M2300172	01/19/23	HAWKI005	HAWKINS DELAFIELD & WOOD LLP	RNG FEASIBILITY	Open	15,741.00	0.00 C
			Contract No: C2300005				
M2300254	01/27/23	SCALF005	SCALFO ELECTRIC	SM-04-21 SCADA Construction	Open	44,098.32	0.00
M2300285	01/27/23	STEWA005	STEWART BUSINESS SYSTEMS	MANAGED PRINT SERVICES	Open	371.25	0.00
M2300310	01/30/23	SUPPR005	SUPPRESSION SYSTEMS, INC.	REPLACEMENT OF 12AH BATTERIES	Open	200.00	0.00
M2300320	01/31/23	PEMBE005	PEMBERTON ELEC. SUPPLY CO. LLC	MISC GAS PLANT SUPPLIES	Open	767.01	0.00
M2300337	02/01/23	MARSH015	MARSH & MCLENNAN AGENCY, LLC	RISK MNGT CONSULTING SERVICES	Open	3,500.00	0.00
M2300420	02/03/23	ACOMM005	A+ COMMERCIAL OFFICE CLEANERS	ADMIN BLDG. JANITORIAL SERVICE	Open	3,075.00	0.00
M2300457	02/07/23	UNIFI005	UNIFIRST CORPORATION	UNIFORM SERVICE FOR LANDFILL	Open	712.00	0.00
M2300458	02/07/23	UNIFI005	UNIFIRST CORPORATION	UNIFORM SERVICE FOR TS	Open	321.20	0.00
M2300459	02/07/23	TOILE005	CAPRIONI PORTABLE TOILETS	PORTABLE TOILETS	Open	260.00	0.00
M2300485	02/09/23	UNIFI005	UNIFIRST CORPORATION	ANNUAL UNIFORM SERVICE	Open	820.73	0.00
M2300486	02/09/23	UNIFI005	UNIFIRST CORPORATION	UNIFORM SERVICE	Open	380.00	0.00
M2300487	02/09/23	UNIFI005	UNIFIRST CORPORATION	UNIFORM SERVICE	Open	601.77	0.00
M2300488	02/09/23	UNIFI005	UNIFIRST CORPORATION	ANNUAL UNIFORM SERVICE	Open	688.08	0.00
M2300496	02/09/23	GRAYB005	GRAYBAR ELECTRIC CO.	UNISTRUT	Open	131.95	0.00
M2300508	02/09/23	APPLI015	APPLIED INDUSTRIAL TECH.	REPLACEMENT RBC BEARING	Open	13,272.65	0.00
M2300516	02/10/23	BUCHA005	BUCHART HORN, INC.	CONTROL PANEL UPGRADES	Open	186.00	0.00 C
			Contract No: C2300011				
M2300517	02/10/23	GANNE005	GANNETT FLEMING, INC.	RFP-45-21 WWL PROCESS AIR	Open	6,562.50	0.00
M2300532	02/13/23	UNIFI005	UNIFIRST CORPORATION	UNIFORM SERVICE	Open	336.38	0.00
M2300578	02/16/23	GENRO005	GENRON FIRE PROTECTION	ROSEMARY FIRE ALARM MAINT.	Open	140.00	0.00
M2300596	02/22/23	GRAYB005	GRAYBAR ELECTRIC CO.	CLARIFIER PROJECT	Open	319.91	0.00
M2300729	03/07/23	FLEET020	FLEET PUMP & SERVICE GROUP	PACKING GLANDS	Open	1,406.10	0.00
M2300848	03/16/23	GRAIN005	GRAINGER INC.	SCADA BUBBLER PROJECT	Open	77.61	0.00
M2301055	04/13/23	WILLI005	WILLIER ELECTRIC MOTOR	REPLACE SLUDGE STORAGE MOTOR	Open	11,197.00	0.00
M2301184	04/28/23	EFFEC005	EFFECTV	2023 tv CAMPAIGN	Open	2,850.03	0.00
M2301273	05/11/23	MURPH010	A. MURPHY & SONS FENCE CO INC.	TS FACILITY MAINT.	Open	1,996.51	0.00
M2301284	05/12/23	LAFAY005	LAFAYETTE UTILITY CONSTRUCTION	46TH STREET PS VALVE REPLACE	Open	24,208.44	0.00 C
			Contract No: C2300001				
M2301298	05/12/23	FOLEY005	FOLEY, INC.	RPO Cat 730 Articul. Dump Truc	Open	13,500.00	0.00
M2301318	05/16/23	LAWNG010	LAWN & GARDEN LANDSCAPING, LLC	LANDSCAPING SERVICES FOR ADMIN	Open	1,115.00	0.00
M2301372	05/23/23	CTRO0005	JERSEY CAPE DIAG. TRAIN. CTR.	LITTER CONTROL SERVICES	Open	1,530.00	0.00 C
			Contract No: C2300025				
M2301392	05/24/23	PHARM005	PHARMA-CARE INC.	Medication Safety Evaluation	Open	48.00	0.00
M2301536	06/09/23	GRAIN005	GRAINGER INC.	GRINDER PARTS	Open	1,347.87	0.00
M2301546	06/13/23	SCHUL005	A. C. SCHULTES	PUMP #16 SECONDARY PUMP	Open	5,489.00	0.00
M2301563	06/15/23	GRAYB005	GRAYBAR ELECTRIC CO.	EATON TRAY - SCADA PROJECT	Open	6,069.72	0.00
M2301583	06/19/23	ATLAN205	ATLANTICARE PHYSICIAN GROUP	PreEmployment Physicals	Open	387.00	0.00
M2301605	06/20/23	APPLI015	APPLIED INDUSTRIAL TECH.	PS 11 & PS 12 PUMP RAILS	Open	3,156.00	0.00
M2301616	06/21/23	JBOLT005	J-BOLTS INDUSTRIAL SUPPLIES	PARKER HYDRAULIC FITTINGS	Open	494.56	0.00
M2301618	06/21/23	HOFFM015	HOFFMAN SERVICES, INC.	ANNUAL VEHICLE LIFT INSPECTION	Open	1,059.00	0.00
M2301622	06/21/23	DELLM005	DELL MARKETING LLC	SKETCHUP SOFTWARE	Open	1,750.32	0.00
M2301686	06/26/23	FWWEB005	F.W.WEBB COMPANY	SS PIPE FOR SUMP PUMPS WWL	Open	823.20	0.00

PO #	PO Date	Vendor	PO Description	Status	Amount	Void Amount	PO Type
M2301701	06/28/23	HACHC005 HACH COMPANY	ANNUAL SERVICE HACH PARTNERSHI	Open	1,566.00	0.00	
M2301710	06/28/23	KENDA005 KENDALL ELECTRIC INC	REPAIR RED LION	Open	3,114.00	0.00	
M2301716	06/28/23	JESCO005 JESCO, INC. Contract No: C2300035	DOZER AND LOADER A/C PARTS	Open	1,684.32	0.00	C
M2301718	06/28/23	FASTE010 FASTENAL & CON. SUPPLIES	SAW BLADES & CRIMPED BRUSHES	Open	698.67	0.00	
M2301724	06/28/23	GRUBE005 GRUBER POWER SERVICE	REPLACEMENT BATTERY	Open	618.77	0.00	
M2301732	06/29/23	ARAMS005 ARAMSCO	CARTRIDGES FOR RESPIRATORS	Open	266.82	0.00	
M2301746	06/30/23	APPLI015 APPLIED INDUSTRIAL TECH.	RBC GEARBOX SPLIT SEALS	Open	726.10	0.00	
M2301747	06/30/23	SWANA005 SWANA, SOLID WASTE AS. OF N.A.	SWANA WASTECON REGISTRATION	Open	1,500.00	0.00	
M2301762	07/06/23	CMCCH005 CMC CHAMBER OF COMMERCE	Seminar on Artificial Intell.	Open	25.00	0.00	
M2301763	07/06/23	GENRO005 GENRON FIRE PROTECTION	TS EXTINGUISHER REPLACEMENT	Open	316.84	0.00	
M2301792	07/11/23	RICHT005 RICH TREE SERVICE, INC.	BURLEIGH TREE REMOVAL	Open	5,970.00	0.00	
M2301797	07/11/23	ADVAN040 STAPLES ADVANTAGE	OFFICE SUPPLIES	Open	144.15	0.00	
M2301799	07/11/23	FOLEY005 FOLEY, INC.	REPAIRS TO CAT TRASH COMPACTOR	Open	4,629.46	0.00	
M2301818	07/14/23	HACHC005 HACH COMPANY	SAMPLE SUPPLIES	Open	626.62	0.00	
M2301829	07/14/23	BURLI010 BURLINGTON ELECTRICAL TESTING	ANNUAL TRANSFORMER OIL SAMPLE	Open	2,800.00	0.00	
M2301907	07/19/23	GRAIN005 GRAINGER INC.	FUSE GENERATORS	Open	288.60	0.00	
M2301918	07/20/23	FASTE010 FASTENAL & CON. SUPPLIES	SPEED RAIL FITTINGS	Open	2,033.52	0.00	
M2301937	07/21/23	APPLI015 APPLIED INDUSTRIAL TECH.	SPRAY NOZZLES FOR SCRUBBER	Open	1,115.45	0.00	
M2301939	07/21/23	GRAIN005 GRAINGER INC.	FUSE FOR ROSEMARY & 10TH GEN	Open	288.60	0.00	
M2301945	07/21/23	KEYST010 KEYSTONE DIGITAL IMAGING CO.	PLOTTER REPAIR	Open	350.00	0.00	
M2301949	07/24/23	BUCHA005 BUCHART HORN, INC. Contract No: C2300011	RFP-52-22 TASK #2	Open	4,556.66	0.00	C
M2301954	07/24/23	SUBUR005 SUBURBAN PROPANE L.P.	PROPANE	Open	182.21	0.00	
M2301958	07/24/23	APPLI015 APPLIED INDUSTRIAL TECH.	ROOF REPAIR MATERIALS	Open	319.50	0.00	
M2301965	07/25/23	SERVI005 SERVICE TIRE TRUCK CENTERS	8, F150 PICKUP TRUCK TIRES	Open	986.32	0.00	
M2301979	07/26/23	HACHC005 HACH COMPANY	POCKET COLORIMETER	Open	510.22	0.00	
M2301980	07/26/23	HACHC005 HACH COMPANY	DPD POWDER PILLOWS, BEAKERS	Open	563.16	0.00	
M2301983	07/26/23	UNISO005 UNISON COMFORT TECHNOLOGIES	HVAC FILTER FOR ADMIN. BLDG	Open	248.64	0.00	
M2301997	07/27/23	GRAIN005 GRAINGER INC.	VARIOUS MAINTENANCE SUPPLIES	Open	2,789.30	0.00	
M2302002	07/28/23	ROBER030 ROBERTS OXYGEN CO. INC.	WELDING WIRE	Open	1,536.68	0.00	
M2302006	07/28/23	YPERS005 Y-PERS, INC.	MISC GAS PLANT SUPPLIES	Open	197.40	0.00	
M2302007	07/28/23	GRAIN005 GRAINGER INC.	MISC GAS PLANT SUPPLIES	Open	606.91	0.00	
M2302008	07/28/23	NAPA0005 SEAVILLE NAPA	MISC GEJ PLANT SUPPLIES	Open	63.28	0.00	
M2302009	07/28/23	KEENC005 KEEN COMPRESSED GAS CO.	GAS CYLINDERS AND TANK RENTAL	Open	188.45	0.00	
M2302010	07/31/23	FOLEY005 FOLEY, INC.	FILTERS FOR C-12 & D-10	Open	4,178.47	0.00	
M2302017	07/31/23	PARAM005 PARAMOUNT SANITARY CHEMICAL CO	JANITORIAL SUPPLIES	Open	1,130.82	0.00	
M2302018	07/31/23	SERVI005 SERVICE TIRE TRUCK CENTERS	TIRES FOR SLUDGE TRUCKS	Open	2,767.35	0.00	
M2302024	07/31/23	HOOVE005 HOOVER TRUCK CENTER	T-39 ENGINE INJECTOR & HARNESS	Open	1,376.86	0.00	
M2302025	08/01/23	CDWGO005 CDW GOVERNMENT INC.	BATTERY BACKUP UNITS	Open	482.60	0.00	
M2302026	08/01/23	ACACI005 ACACIA FINANCIAL GROUP, INC.	FINANCIAL ADVISORY SERVICES	Open	3,037.50	0.00	
M2302027	08/01/23	GENER035 GENERAL SPRING & ALIGNMENT, IN	REPAIRS TO T-19 KENWORTH	Open	1,932.42	0.00	
M2302029	08/01/23	GENER035 GENERAL SPRING & ALIGNMENT, IN	REPAIRS TO T-20 KENWORTH	Open	1,932.42	0.00	
M2302030	08/01/23	INSIG010 INSIGHT PUBLIC SECTOR, INC.	SEAMLESSDOCS RENEWAL	Open	5,779.15	0.00	
M2302031	08/01/23	CDWGO005 CDW GOVERNMENT INC.	BATTERY BACKUP UNITS	Open	361.95	0.00	
M2302032	08/01/23	CDWGO005 CDW GOVERNMENT INC.	COMPUTER SPEAKERS	Open	187.48	0.00	
M2302033	08/01/23	CDWGO005 CDW GOVERNMENT INC.	COMPUTER SPEAKERS	Open	187.48	0.00	
M2302034	08/01/23	CDWGO005 CDW GOVERNMENT INC.	COMPUTER SPEAKERS	Open	187.48	0.00	
M2302039	08/01/23	CWMIL005 CW MILL EQUIPMENT CO. INC.	ADJUSTER ROD NUTS	Open	59.09	0.00	
M2302040	08/02/23	KUEHN005 KUEHNE CHEMICAL CO. INC. Contract No: C2300015	SODIUM HYPOCHLORITE - OC	Open	9,047.07	0.00	C
M2302041	08/02/23	KUEHN005 KUEHNE CHEMICAL CO. INC. Contract No: C2300015	SODIUM HYPOCHLORITE - OC	Open	9,173.91	0.00	C
M2302046	08/02/23	TRAIL005 HALE TRAILER	PLASTIC BEARINGS FOR FLOOR SLA	Open	1,760.00	0.00	

PO #	PO Date	Vendor	PO Description	Status	Amount	Void Amount	PO Type
M2302047	08/02/23	NAPA0005 SEAVILLE NAPA	FILTERS FOR STOCK	Open	2,808.78	0.00	
M2302048	08/02/23	SOUTH050 SOUTH JERSEY WELDING	LINCOLN ELECTRIC GAS DIFFUSERS	Open	160.43	0.00	
M2302051	08/02/23	KEMIR005 KEMIRA WATER SOLUTIONS INC. Contract No: C2300016	LIQUID FERRIC CHLORIDE	Open	12,139.73	0.00	C
M2302052	08/02/23	NAPA0005 SEAVILLE NAPA	VACUUM FILTERS	Open	152.76	0.00	
M2302053	08/02/23	COYNE005 COYNE CHEMICAL COMPANY Contract No: C2300045	HYDROGEN PEROXIDE TOTES	Open	3,836.59	0.00	C
M2302056	08/02/23	GRAIN005 GRAINGER INC.	NOZZLE, AIR HOSE, SEALANT	Open	363.90	0.00	
M2302058	08/02/23	GRAIN005 GRAINGER INC.	MISC SLF SUPPLIES	Open	294.28	0.00	
M2302059	08/02/23	GRAIN005 GRAINGER INC.	CORD REEL, ELECTRICAL WIRE	Open	668.86	0.00	
M2302060	08/02/23	FASTE010 FASTENAL & CON. SUPPLIES	MISC GAS PLANT SUPPLIES	Open	635.53	0.00	
M2302061	08/02/23	GRAIN005 GRAINGER INC.	STORAGE CABINET	Open	442.48	0.00	
M2302063	08/03/23	GRAIN005 GRAINGER INC.	FILTER ELEMENT	Open	1,288.71	0.00	
M2302066	08/03/23	GRAIN005 GRAINGER INC.	WATER COOLER, FILTER/AERATOR	Open	246.76	0.00	
M2302067	08/03/23	GRAIN005 GRAINGER INC.	ULTRASONIC TRANSMITTER	Open	2,931.74	0.00	
M2302068	08/03/23	GRAIN005 GRAINGER INC.	PARTS FOR PEROXIDE LINE	Open	316.99	0.00	
M2302073	08/03/23	WECAR005 WECARE DENALI, LLC	COMPOST FOR TERRAGRO	Open	487.50	0.00	
M2302074	08/03/23	GRAIN005 GRAINGER INC.	MISC SITE SUPPLIES	Open	780.20	0.00	
M2302075	08/03/23	ADVAN040 STAPLES ADVANTAGE	MISC OFFICE SUPPLIES	Open	51.70	0.00	
M2302077	08/03/23	IDEXX005 IDEXX DISTRIBUTION INC.	LAB SUPPLIES	Open	2,657.08	0.00	
M2302078	08/03/23	GRAYB005 GRAYBAR ELECTRIC CO.	EXPANSION COUPLINGS SLUDGE	Open	1,931.52	0.00	
M2302079	08/03/23	COYNE005 COYNE CHEMICAL COMPANY Contract No: C2300013	DRY POLYMER - ZETAG 7587	Open	16,850.45	0.00	C
M2302082	08/03/23	PEMBE005 PEMBERTON ELEC. SUPPLY CO. LLC	REPLACEMENT LED LIGHTS EFF BLD	Open	1,062.00	0.00	
M2302083	08/03/23	PAULS010 PAUL'S PEST CONTROL	10TH STREET OUTDOOR RODENTS	Open	250.00	0.00	
M2302084	08/03/23	GENRO005 GENRON FIRE PROTECTION	FIRE EXTINGUISHER SERVICES	Open	141.00	0.00	
M2302085	08/03/23	HORIZ010 HORIZON EYE CARE	JOHN STANTON SAFETY GLASSES	Open	239.00	0.00	
M2302086	08/04/23	TURLT005 TURTLE & HUGHES, INC.	75 HP PUMPS - EFF PUMP VFD	Open	1,185.50	0.00	
M2302087	08/04/23	TURLT005 TURTLE & HUGHES, INC.	SWITCH FOR GRINDER	Open	159.76	0.00	
M2302089	08/04/23	APPLI015 APPLIED INDUSTRIAL TECH.	FLOAT ASSY GENERATOR FUEL TANK	Open	754.75	0.00	
M2302092	08/04/23	APPLI015 APPLIED INDUSTRIAL TECH.	GREASE	Open	1,678.22	0.00	
M2302097	08/04/23	NAPA0005 SEAVILLE NAPA	C-11 BACKUP CAMERA & FILTERS	Open	764.21	0.00	
M2302100	08/04/23	LABOR015 LABORATORY SALES & SERVICE LLC	LABORATORY SUPPLIES	Open	615.77	0.00	
M2302104	08/04/23	GRAIN005 GRAINGER INC.	CLAMPS, ADAPTER, COUPLING	Open	333.96	0.00	
M2302105	08/04/23	KUEHN005 KUEHNE CHEMICAL CO. INC. Contract No: C2300015	SODIUM HYPOCHLORITE - WW	Open	8,778.43	0.00	C
M2302106	08/04/23	KUEHN005 KUEHNE CHEMICAL CO. INC. Contract No: C2300015	SODIUM HYPOCHLORITE - WW	Open	8,722.59	0.00	C
M2302107	08/04/23	KUEHN005 KUEHNE CHEMICAL CO. INC. Contract No: C2300015	SODIUM HYPOCHLORITE - WW	Open	8,909.29	0.00	C
M2302113	08/07/23	PEDRO005 PEDRONI FUEL CO.	UNLEADED GAS DELIVERY 7/25/23	Open	2,835.85	0.00	
M2302114	08/07/23	KUEHN005 KUEHNE CHEMICAL CO. INC. Contract No: C2300015	SODIUM HYPOCHLORITE 8/11/23	Open	9,137.96	0.00	C
M2302116	08/07/23	NORTH045 NORTH EAST TECH. SALES INC.	FLUKE TESTER	Open	1,256.84	0.00	
M2302117	08/07/23	PARAM005 PARAMOUNT SANITARY CHEMICAL CO	TISSUES, TOWELS, SOAP	Open	735.86	0.00	
M2302119	08/08/23	COMMA005 COMMAND RADIO COMMUNICATIONS	BATTERIES	Open	367.36	0.00	
M2302120	08/08/23	FAZZI005 FAZZIO, JOSEPH, INC.BLD.	AIRLINE FOR RBC BAY	Open	628.80	0.00	
M2302122	08/08/23	GRAIN005 GRAINGER INC.	NEC CODE BOOK 2023	Open	234.84	0.00	
M2302123	08/08/23	PEDRO005 PEDRONI FUEL CO.	NO LEAD GAS LANDFILL	Open	1,747.36	0.00	
M2302125	08/08/23	QEDEN005 QED ENVIROMENTAL SYSTEMS INC.	MISC GAS PLANT SUPPLIES	Open	3,070.79	0.00	
M2302127	08/08/23	NJWAT015 NJ WATER ENVIRONMENT ASSOC.	NJWEA SEMINAR REGISTRATION	Open	270.00	0.00	
M2302129	08/08/23	PARAM005 PARAMOUNT SANITARY CHEMICAL CO	JANITORIAL SUPPLIES	Open	319.10	0.00	
M2302130	08/08/23	CODYS005 CODY'S POWER EQUIPMENT	M-29 LAWN MOWER FUEL TANK	Open	458.71	0.00	

PO #	PO Date	Vendor	PO Description	Status	Amount	Void Amount	PO Type
M2302131	08/09/23	KUEHN005 KUEHNE CHEMICAL CO. INC. Contract No: C2300015	SODIUM HYPOCHLORITE - OC	Open	9,112.23	0.00	C
M2302132	08/09/23	KUEHN005 KUEHNE CHEMICAL CO. INC. Contract No: C2300015	SODIUM HYPOCHLORITE - OC	Open	9,134.67	0.00	C
M2302133	08/09/23	PYRZW005 PYRZ WATER SUPPLY CO.,INC.	HYDROGEN PEROXIDE TANK INSTALL	Open	850.00	0.00	
M2302134	08/09/23	COVAN005 COVANTA ENV. SOLUTIONS, LLC Contract No: C2300020	electronics PU SLF TS OC	Open	1,233.30	0.00	C
M2302136	08/09/23	FWWEB005 F.W.WEBB COMPANY	MISC GAS PLANT SUPPLIES	Open	584.82	0.00	
M2302137	08/09/23	RECOV020 INTERSTATE REFRIGERANT RECOVER	CFC service	Open	1,536.00	0.00	
M2302140	08/09/23	RARIT015 RARITAN GROUP INCORPORATED	SHAWCREST 6" FLANGE	Open	536.84	0.00	
M2302141	08/09/23	FASTE010 FASTENAL & CON. SUPPLIES	MAINTENANCE	Open	92.00	0.00	
M2302142	08/09/23	FASTE010 FASTENAL & CON. SUPPLIES	TUBING FOR PEROXIDE INSTALL	Open	756.00	0.00	
M2302143	08/09/23	KUEHN005 KUEHNE CHEMICAL CO. INC. Contract No: C2300015	SODIUM HYPOCHLORITE - CAPE MAY	Open	8,953.63	0.00	C
M2302144	08/09/23	PARAM005 PARAMOUNT SANITARY CHEMICAL CO	TS JANITORIAL SUPPLIES	Open	256.58	0.00	
M2302147	08/09/23	BATTE005 BATTELETT TRANSPORTATION SYS INC	TOW T-43 TO BRISTOL CUMMINS	Open	1,075.00	0.00	
M2302150	08/10/23	NJLEA005 NJ LEAGUE MUNICIPALITIES	Ad: Admin Services Asst.	Open	160.00	0.00	
M2302152	08/10/23	LOWES005 LOWE'S COMMERCIAL SERVICES	MAINTENANCE	Open	40.69	0.00	
M2302154	08/10/23	SOUTH010 SOUTHERN NEW JERSEY NIGP	SEPTEMBER PURCHASING MEETING	Open	152.00	0.00	
M2302155	08/10/23	SHERW005 SHERWIN-WILLIAMS CO.	PAINT FOR SMM SCUM CAN	Open	639.54	0.00	
M2302156	08/10/23	EASTC055 EAST COAST STEEL INC.	SS FOR O.C RBR	Open	8,712.10	0.00	
M2302157	08/10/23	FASTE010 FASTENAL & CON. SUPPLIES	SANDBLASTER PARTS	Open	860.00	0.00	
M2302158	08/10/23	GRAIN005 GRAINGER INC.	EXTENSION CORDS	Open	388.32	0.00	
M2302159	08/10/23	KEMIR005 KEMIRA WATER SOLUTIONS INC. Contract No: C2300016	LIQUID FERRIC CHLORIDE	Open	11,889.26	0.00	C
M2302160	08/10/23	SERVI005 SERVICE TIRE TRUCK CENTERS Contract No: C2300028	L-29 TIRE REPAIR	Open	446.50	0.00	C
M2302161	08/10/23	MEDIA025 SAMPLE MEDIA	RECYCLING ADS	Open	1,560.00	0.00	
M2302162	08/10/23	NAPA0005 SEAVILLE NAPA	FUEL AND AIR FILTERS FORKLIFT	Open	38.21	0.00	
M2302163	08/10/23	LOWES005 LOWE'S COMMERCIAL SERVICES	SAWZAL BLADES, BALL VALVE	Open	34.81	0.00	
M2302164	08/10/23	LOWES005 LOWE'S COMMERCIAL SERVICES	FOUNTAIN PUMP FOR DRILL PRESS	Open	47.49	0.00	
M2302165	08/10/23	LOWES005 LOWE'S COMMERCIAL SERVICES	WWL VFD PROJECT	Open	28.28	0.00	
M2302166	08/10/23	NAPA0005 SEAVILLE NAPA	IR COMPRESSOR	Open	9.94	0.00	
M2302167	08/10/23	COLON005 COLONIAL ELECTRIC SUPPLY	LOCKING KNIFE - ELECTRICIAN	Open	49.90	0.00	
M2302168	08/10/23	PEDRO005 PEDRONI FUEL CO.	UNLEADED GASOLINE	Open	848.06	0.00	
M2302169	08/10/23	COYNE005 COYNE CHEMICAL COMPANY Contract No: C2300037	EMULSON POLYMER-ZETAG 8848FS	Open	20,301.60	0.00	C
M2302171	08/11/23	GRAIN005 GRAINGER INC.	WATER REUSE SUMP PUMPS	Open	975.86	0.00	
M2302172	08/11/23	GRAIN005 GRAINGER INC.	PROXIMITY SWITCH WATER COOLER	Open	140.49	0.00	
M2302173	08/11/23	GRAIN005 GRAINGER INC.	ELBOWS FOR SCRUBBER PIPING	Open	105.30	0.00	
M2302174	08/11/23	GRAIN005 GRAINGER INC.	2" LOCK NUTS	Open	90.98	0.00	
M2302177	08/11/23	FASTE010 FASTENAL & CON. SUPPLIES	GRADE 8 HARDWARE	Open	1,114.97	0.00	
M2302179	08/11/23	LOWES005 LOWE'S COMMERCIAL SERVICES	MAINTENANCE	Open	42.72	0.00	
M2302180	08/11/23	SWAIN005 SWAIN'S HARDWARE STORE	GLUE & CLEANERS	Open	14.58	0.00	
M2302181	08/11/23	PEDRO005 PEDRONI FUEL CO.	UNLEADED GASOLINE	Open	757.20	0.00	
M2302183	08/15/23	KUEHN005 KUEHNE CHEMICAL CO. INC. Contract No: C2300015	SODIUM HYPOCHLORITE 8/18/23	Open	8,830.26	0.00	C
M2302186	08/15/23	GARTO005 GARTON'S RIGGING INC. Contract No: C2300023	55 ton crane	Open	1,400.00	0.00	C
M2302187	08/15/23	GARTO005 GARTON'S RIGGING INC. Contract No: C2300023	55 ton crane	Open	1,400.00	0.00	C
M2302188	08/15/23	DALEY005 DALEY'S PIT Contract No: C2200067	BACKHAULED RECYCLED MATERIAL	Open	563.13	0.00	C
M2302190	08/15/23	LCEQU005 L C EQUIPMENT INC.	FIRE ROOF TRUSS SIGNS	Open	150.00	0.00	

PO #	PO Date	Vendor	PO Description	Status	Amount	Void Amount	PO Type
M2302191	08/15/23	GRAIN005 GRAINGER INC.	FIRE SAFETY SIGNS	Open	87.86	0.00	
M2302192	08/15/23	SPRAG005 SPRAGUE OPERATING RESOURCES	DIESEL FUEL LANDFILL	Open	34,844.29	0.00	
M2302193	08/15/23	TREAS020 TREASURER, STATE OF NEW JERSEY	AIR PERMITS	Open	885.00	0.00	
M2302196	08/16/23	NATIO070 NATIONAL SAFETY COUNCIL	NSC CONGRESS 2023 ATTENDANCE	Open	1,059.00	0.00	
M2302198	08/16/23	KEENC005 KEEN COMPRESSED GAS CO.	GAS CYLINDERS AND TANK RENTAL	Open	80.66	0.00	
M2302199	08/16/23	CODYS005 CODY'S POWER EQUIPMENT	MISC GAS PLANT SUPPLIES	Open	25.99	0.00	
M2302200	08/16/23	ADVAN035 ADVANTAGE RENTAL CENTER	MISC GAS PLANT SUPPLIES	Open	23.62	0.00	
M2302202	08/16/23	JBOLT005 J-BOLTS INDUSTRIAL SUPPLIES	MISC GAS PLANT SUPPLIES	Open	372.74	0.00	
M2302207	08/16/23	DENNI005 DENNISVILLE FENCE CO.	39TH STREET FENCE REPAIR	Open	83.73	0.00	
M2302208	08/16/23	JAMES025 JAMES BLAKE	WORK BOOTS	Open	275.00	0.00	
M2302210	08/16/23	TOWNC010 TOWN COMMUNICATIONS	TS PORTABLE TWO-WAY RADIOS	Open	615.00	0.00	
M2302213	08/16/23	GRAIN005 GRAINGER INC.	LABEL PEROXIDE TANK	Open	129.48	0.00	
M2302215	08/16/23	LOWES005 LOWE'S COMMERCIAL SERVICES	DRYER BELT	Open	16.15	0.00	
M2302216	08/16/23	NAPA0005 SEAVILLE NAPA	FUEL FILTER PLANT GENERATOR 2	Open	44.30	0.00	
M2302217	08/16/23	SEXT0010 PATRICK M. SEXTON	REIMBURSE FOR S2 & C2 LICENSE	Open	100.00	0.00	
M2302218	08/16/23	VILLA015 VILLAS NAPA AUTO PARTS	EXHAUST FAN BELT BLEACH ROOM	Open	12.15	0.00	
M2302224	08/17/23	EUROF005 EUROFINS ENV TESTING PHILA LLC	LAB TESTING	Open	1,425.00	0.00	C
		Contract No: C2200022					
M2302227	08/17/23	GRAIN005 GRAINGER INC.	SHOP TOOLS	Open	139.08	0.00	
M2302228	08/17/23	GRAIN005 GRAINGER INC.	SANDING BELTS	Open	387.24	0.00	
M2302230	08/17/23	FASTE010 FASTENAL & CON. SUPPLIES	COATED GLOVES	Open	640.80	0.00	
M2302231	08/17/23	HUBER005 HUBER LOCKSMITHS, INC.	SITE SURVEY	Open	375.00	0.00	
M2302233	08/17/23	LOWES005 LOWE'S COMMERCIAL SERVICES	WWL SCUM PIT JOB	Open	44.19	0.00	
M2302235	08/17/23	MULTI015 MULTI-TEMP MECHANICAL, INC.	EMERGENCY HOT WATER HEATER	Open	470.00	0.00	C
		Contract No: C2300003					
M2302237	08/17/23	NAPA0005 SEAVILLE NAPA	MAINTENANCE	Open	47.91	0.00	
M2302242	08/18/23	SEYMO005 STEVEN SEYMOUR	REIMBURSE FOR WW LICENSE	Open	100.00	0.00	
M2302245	08/18/23	ADVAN010 ADVANCE SCALE CO. INC.	TRUCK SCALE INSPECTIONS TS	Open	480.00	0.00	C
		Contract No: C2300029					
M2302248	08/18/23	ADVAN035 ADVANTAGE RENTAL CENTER	PLATE ADAPTERS, CLAMP SET	Open	37.83	0.00	
M2302253	08/18/23	GRAYB005 GRAYBAR ELECTRIC CO.	DRILL BITS FOR ELECTRIC WORK	Open	69.12	0.00	
M2302256	08/21/23	SERVI005 SERVICE TIRE TRUCK CENTERS	OFF HIGHWAY TIRE REPAIR	Open	792.50	0.00	C
		Contract No: C2300028					
M2302258	08/21/23	SWANA005 SWANA, SOLID WASTE AS. OF N.A.	2023 MEMBERSHIP DUES	Open	122.49	0.00	
M2302259	08/21/23	MIDDL025 MIDDLE TWP. FIRE DISTRICT #1	REGISTRATION FEES FOR SCF	Open	384.00	0.00	
M2302262	08/22/23	NAPA0005 SEAVILLE NAPA	REPAIRS PARTS FOR F-150 PC-1	Open	113.32	0.00	
M2302263	08/22/23	SUBUR005 SUBURBAN PROPANE L.P.	PROPANE	Open	868.00	0.00	
M2302264	08/22/23	LOWES005 LOWE'S COMMERCIAL SERVICES	WWL SCUM PROJECT	Open	42.26	0.00	
M2302265	08/22/23	NJWAT015 NJ WATER ENVIRONMENT ASSOC.	NJWEA SEMINAR	Open	587.00	0.00	
M2302267	08/22/23	SPECI035 SPECIALTY AUTOMOTIVE EQUIP.	LIFT INSPECTIONS WWTF PLANTS	Open	1,200.00	0.00	
M2302268	08/22/23	TREAS145 TREASURER, STATE OF N.J., DCA	FIRE SAFETY PERMIT APPLICATION	Open	481.00	0.00	
M2302272	08/23/23	SCALF005 SCALFO ELECTRIC	GEJ5 & GEJ6 CUTOUT FUSES	Open	1,138.81	0.00	C
		Contract No: C2300002					
M2302273	08/23/23	NJWAT015 NJ WATER ENVIRONMENT ASSOC.	2023 FALL TECH TRANSFERS	Open	675.00	0.00	
M2302274	08/23/23	ADVAN035 ADVANTAGE RENTAL CENTER	MISC SITE SUPPLIES	Open	45.37	0.00	
M2302275	08/23/23	GARDN005 GARDNER TRUE VALUE	69TH ST PEROXIDE SETUP	Open	44.38	0.00	
M2302276	08/23/23	GARDN005 GARDNER TRUE VALUE	39TH ST FENCE REPAIR	Open	26.97	0.00	
M2302277	08/23/23	BATTE005 BATELLINI TRANSPORTION SYS INC	TOWING FOR E-350 PC-6	Open	350.00	0.00	
M2302287	08/24/23	GRAIN005 GRAINGER INC.	COMPACT IMPACT WRENCH	Open	252.02	0.00	
M2302288	08/24/23	SOUTH050 SOUTH JERSEY WELDING	WELDING GASES	Open	214.18	0.00	
M2302290	08/24/23	KUEHN005 KUEHNE CHEMICAL CO. INC.	SODIUM HYPOCHLORITE - OC	Open	9,717.59	0.00	C
		Contract No: C2300050					
M2302292	08/24/23	NAPA0005 SEAVILLE NAPA	ADDITIONAL PARTS F-150 PC1	Open	121.77	0.00	
M2302294	08/24/23	SPRAG005 SPRAGUE OPERATING RESOURCES	DIESEL FUEL INV 505062 8/17/23	Open	7,633.83	0.00	

PO #	PO Date	Vendor	PO Description	Status	Amount	Void Amount	PO Type
M2302305	08/25/23	LOWES005	LOWE'S COMMERCIAL SERVICES GALVENIZED PLUGS	Open	7.16	0.00	
M2302306	08/25/23	NAPA0005	SEAVILLE NAPA PICK-UP SLIPS SHOP SUPPLIES	Open	87.68	0.00	
M2302309	08/28/23	GARDN005	GARDNER TRUE VALUE PC MAINTENANCE	Open	24.87	0.00	
M2302310	08/28/23	LOWES005	LOWE'S COMMERCIAL SERVICES WWL MCC-2 FEED DEMO	Open	39.11	0.00	
M2302315	08/28/23	SPRAG005	SPRAGUE OPERATING RESOURCES DIESEL FUEL LANDFILL	Open	24,572.03	0.00	
M2302317	08/28/23	MULTI015	MULTI-TEMP MECHANICAL, INC. EMERGENCY MINI-SPLIT SCALE 1	Open	188.00	0.00	C
			Contract No: C2300003				
M2302318	08/28/23	MAKOW005	NICHOLAS J. MAKOWSKI REIMBURSE FOR S1 & C2 LICENSE	Open	100.00	0.00	
M2302320	08/28/23	LOWES005	LOWE'S COMMERCIAL SERVICES MAINTENANCE	Open	42.42	0.00	
M2302333	08/30/23	NAPA0005	SEAVILLE NAPA SHOP SUPPLIES PICK-UP SLIPS	Open	140.29	0.00	
V2300605	08/07/23	VERIZ010	VERIZON WIRELESS UTILITIES- 6/29/23-7/28/23	Open	76.02	0.00	
V2300632	08/11/23	WASTE005	CMCMA SOLID WASTE DISPOSAL FEES	Open	5,576.75	0.00	
V2300633	08/11/23	ATLAN140	ATLANTIC CITY ELECTRIC UTILITIES	Open	13,349.29	0.00	
V2300634	08/14/23	UNITE025	UNITED PARCEL SERVICE POSTAGE	Open	13.78	0.00	
V2300635	08/14/23	DAILY005	DAILY JOURNAL LEGAL ADVERTISING- AUGUST 2023	Open	29.64	0.00	
V2300636	08/15/23	ENTER020	ENTERPRISE FM TRUST VEHICLE LEASE- WASTEWATER	Open	12,460.66	0.00	
V2300637	08/15/23	ENTER020	ENTERPRISE FM TRUST VEHICLE LEASE-ADMINISTRATION	Open	4,499.62	0.00	
V2300638	08/15/23	ENTER020	ENTERPRISE FM TRUST VEHICLE LEASE- SW ENFORCEMENT	Open	355.02	0.00	
V2300639	08/16/23	WINDS005	WINDSTREAM UTILITIES	Open	19.68	0.00	
V2300640	08/22/23	ABCO005	ABCO PUBLIC EMPLOYEES CREDIT UNION	Open	550.26	0.00	
V2300641	08/22/23	NATIO045	NATIONWIDE RETIREMENT SOLUTION DEFERRED COMPENSATION W/H	Open	17,585.00	0.00	
V2300642	08/22/23	NEWJE050	NEW JERSEY FAMILY SUPPORT GARNISHMENTS	Open	684.00	0.00	
V2300643	08/22/23	ISABE005	ISABEL C.BALBOA, CHAPTER 13 TR CASE NUMBER 18-28741	Open	463.50	0.00	
V2300644	08/22/23	HEALT005	HEALTH EQUITY EMPLOYEE HEALTH SAVINGS ACCTS.	Open	1,629.20	0.00	
V2300645	08/22/23	DUES0005	TEAMSTERS LOCAL 331 DUES UNION DUES	Open	3,447.50	0.00	
V2300646	08/22/23	POLIT005	TEAMSTERS LOCAL 331 POLITICAL POLITICAL ACTION FUND	Open	18.00	0.00	
V2300647	08/22/23	SOCIA005	TEAMSTERS LOCAL 331 SOCIAL UNION SOCIAL FUND	Open	5.00	0.00	
V2300648	08/22/23	UNUMP005	UNUM/PROVIDENT LIFE & ACCIDENT INSURANCE W/H	Open	647.82	0.00	
V2300649	08/22/23	AFLAC005	AFLAC US INSURANCE W/H	Open	3,091.96	0.00	
V2300650	08/22/23	DEPAR015	DEPARTMENT OF THE TREASURY FICA TAXES & FED INCOME TAX	Open	125,452.30	0.00	
V2300651	08/22/23	NJDIV015	NJ DIVISION OF TAXATION STATE INCOME TAX	Open	20,226.69	0.00	
V2300652	08/22/23	CAPEM055	CAPE MAY COUNTY MUA ADJUSTED PAYROLL CMCMA	Open	303,667.86	0.00	
V2300653	08/22/23	NJDIV010	NJ DIVISION OF PENSIONS PENSION W/H	Open	99,881.39	0.00	
V2300654	08/22/23	WADEL005	WADE, LONG, & WOOD, LLC LEGAL FEES-GEN LEGAL JUNE 2023	Open	4,239.50	0.00	
V2300655	08/22/23	WADEL005	WADE, LONG, & WOOD, LLC LEGAL FEES-LABOR NEGOTIATIONS	Open	1,386.00	0.00	
V2300656	08/22/23	WADEL005	WADE, LONG, & WOOD, LLC LEGAL FEES-RECYCLING JUNE 2023	Open	2,572.50	0.00	
V2300657	08/22/23	WADEL005	WADE, LONG, & WOOD, LLC LEGAL FEES-SW GENERAL JUN 2023	Open	1,333.50	0.00	
V2300658	08/22/23	WADEL005	WADE, LONG, & WOOD, LLC LEGAL FEES- WW GEN JUNE 2023	Open	1,711.50	0.00	
V2300659	08/22/23	UNITE135	UNITED HEALTHCARE INSURANCE CO Health Insur. Vision SEPT 2023	Open	1,800.10	0.00	
V2300660	08/23/23	WADEL005	WADE, LONG, & WOOD, LLC LEGAL FEES-GEN LEGAL JULY 2023	Open	957.50	0.00	
V2300661	08/23/23	WADEL005	WADE, LONG, & WOOD, LLC LEGAL FEES-LABOR NEGOTIATIONS	Open	357.00	0.00	
V2300662	08/23/23	WADEL005	WADE, LONG, & WOOD, LLC LEGAL FEES-RECYCLING JULY 2023	Open	1,312.50	0.00	
V2300663	08/23/23	WADEL005	WADE, LONG, & WOOD, LLC LEGAL FEES-SW GENERAL JUL 2023	Open	2,226.00	0.00	
V2300664	08/23/23	WADEL005	WADE, LONG, & WOOD, LLC LEGAL FEES- WW GEN JULY 2023	Open	4,053.00	0.00	
V2300665	08/24/23	BOROU020	BOROUGH OF STONE HARBOR UTILITIES	Open	561.00	0.00	
V2300666	08/24/23	SOUTH060	SOUTH JERSEY GAS UTILITIES	Open	214.59	0.00	
V2300667	08/24/23	NJAME005	NJ AMERICAN WATER COMPANY UTILITIES	Open	185.24	0.00	
V2300668	08/24/23	ATLAN140	ATLANTIC CITY ELECTRIC UTILITIES	Open	15,613.63	0.00	
V2300669	08/24/23	ATLAN140	ATLANTIC CITY ELECTRIC UTILITIES ACCT #926 AUG	Open	24.46	0.00	
V2300670	08/28/23	UNITE025	UNITED PARCEL SERVICE POSTAGE	Open	23.35	0.00	
V2300671	08/28/23	STATE110	STATE OF NEW JERSEY HEALTH INSURANCE-SEPT 2023	Open	100,096.56	0.00	
V2300672	08/28/23	STATE110	STATE OF NEW JERSEY HEALTH INSURANCE-SEPT 2023	Open	318,571.70	0.00	
V2300673	08/28/23	COMCA015	COMCAST BUSINESS COMMUNICATION COMCAST DR CONNECTION	Open	556.00	0.00	
V2300674	08/30/23	NJAME005	NJ AMERICAN WATER COMPANY UTILITIES	Open	4,695.90	0.00	

PO #	PO Date	Vendor	PO Description	Status	Amount	Void Amount	PO Type
V2300675	08/30/23	CMCMU050 CMCMA	PETTY CASH	Open	83.76	0.00	
V2300676	08/30/23	CMCMU050 CMCMA	PETTY CASH	Open	41.68	0.00	
V2300677	08/30/23	CMCMU050 CMCMA	PETTY CASH	Open	35.00	0.00	
V2300678	08/30/23	SOUTH060 SOUTH	JERSEY GAS	Open	1,772.86	0.00	
V2300679	08/30/23	ATLAN140 ATLANTIC	CITY ELECTRIC	Open	33,033.88	0.00	
V2300680	08/30/23	PITNE010 PITNEY	BOWES BANK INC	Open	1,000.00	0.00	
V2300681	08/30/23	NJAME005 NJ	AMERICAN WATER	Open	202.75	0.00	
V2300682	08/31/23	SOUTH060 SOUTH	JERSEY GAS	Open	1,745.13	0.00	
Total Purchase Orders: 292 Total P.O. Line Items: 0 Total List Amount: 1,664,623.09 Total Void Amount:							0.00

Totals by Year-Fund Fund Description	Fund	Expend Total	Revenue Total	G/L Total	Total
ADMINISTRATION	3-100	1,020,799.09	0.00	15,438.89	1,036,237.98
WASTEWATER OPERATIONS	3-200	347,406.35	0.00	0.00	347,406.35
SOLID WASTE OPERATIONS	3-300	144,089.65	0.00	0.00	144,089.65
SOLID WASTE PROJECT	3-400	15,927.00	0.00	0.00	15,927.00
RENEWAL & REPLACEMENT	3-720	120,962.11	0.00	0.00	120,962.11
Total of All Funds:		1,649,184.20	0.00	15,438.89	1,664,623.09

Cape May County Municipal Utilities Authority

CERTIFICATION OF FUNDS:

I hereby certify that funds are available for payment of vouchers on the Cape May County Municipal Utilities Authority's Vouchers Listing:

- Administration
- Wastewater Operations
- Wastewater Project
- Solid Waste Operations
- Solid Waste Project

all said Vouchers Lists dated September 6, 2023.



Robert P. Donato, CPA
Chief Financial Officer