

- NO EXCEPTIONS NOTED
- MAKE CORRECTIONS NOTED
- REJECTED     REVISE AND RESUBMIT
- SUBMIT SPECIFIED ITEM

Checking is only for general conformance with the design concept of the project and general compliance with the information given in the contract documents. Any action shown is subject to the requirements of the plans and specifications. The contractor is responsible for dimensions which shall be confirmed and correlated at the job site. Application of processes and techniques of construction in coordination of his work with that of all other trades and the satisfactory performance of his work.

By       
 Date 12/19/86  
**CH2M HILL**  
 2020 S. W. 4th, 2nd Floor  
 Portland, Oregon 97201

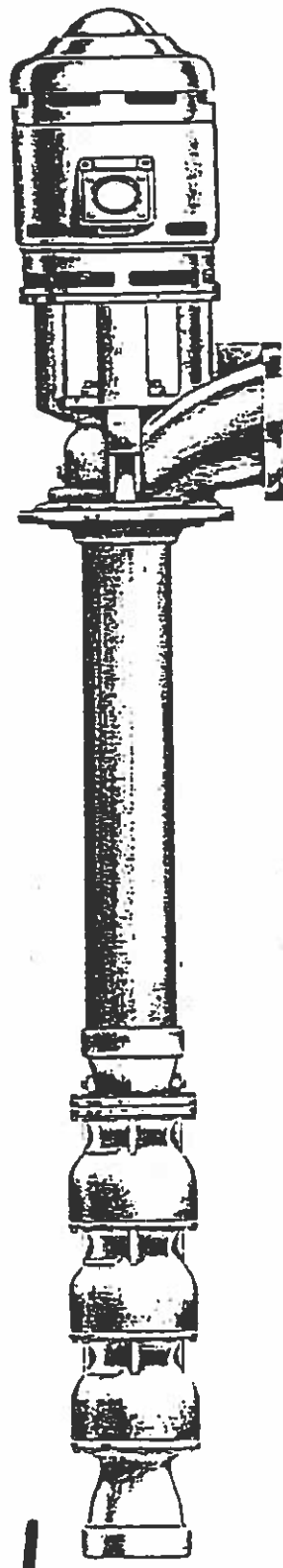
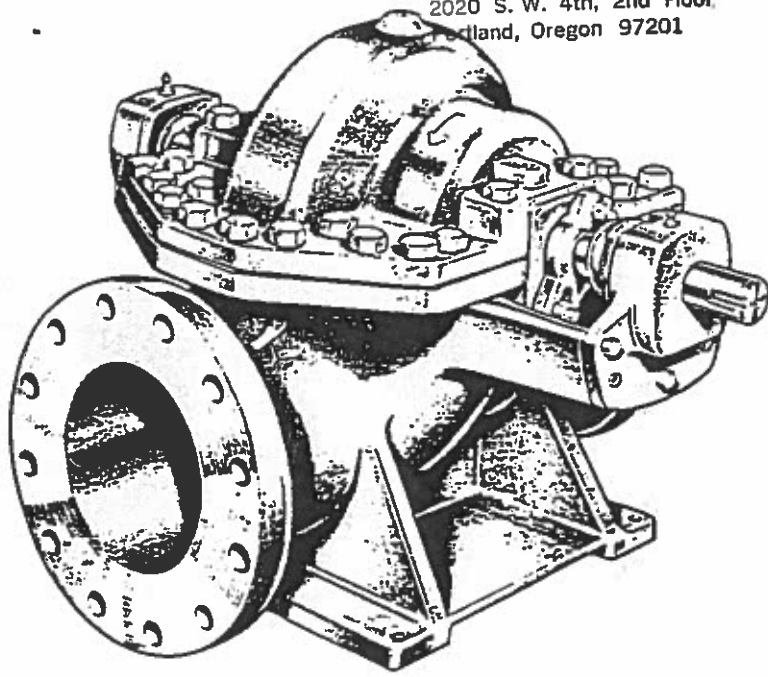

**ROSEMARY Rd.**

Fairbanks Morse Pump Corporation

3601 Fairbanks Avenue  
 Kansas City, KS 66110

# Fairbanks Morse Pump Corporation

## INSTRUCTION MANUAL

FOR

CAPE MAY COUNTY  
MUNICIPAL UTILITIES AUTHORITY  
REGIONAL WASTEWATER FACILITIES  
CAPE MAY COUNTY, NEW JERSEY  
CONTRACT WW/L-PS-1

**CONTRACTOR:** ROSS-ARACO CORPORATION  
PLYMOUTH MEETING, PENNSYLVANIA

**ENGINEER:** PQA ENGINEERING COMPANY

**MANUFACTURERS:**

**PUMPS:** FAIRBANKS MORSE PUMP DIVISION  
KANSAS CITY, KANSAS

**MOTORS:** MARATHON MOTORS  
WAUSAU, WISCONSIN

**SERVICE:** ROSEMARY ROAD PUMPING STATION

**SERIAL NUMBER:** K3N1-060655-0, K3N1-060655-1, K3N1-060655-2

**PUMP SIZE:** (3) 8 X 10 B5415

R.C.W.  
11/19/86

## TABLE OF CONTENTS

### SECTION I. FAIRBANKS MORSE PUMPS

Certified Performance Curve (Present)	K3N1-060655-0
Certified Performance Curve (Future)	K3N1-060655-0
Certified Performance Curve (Present)	K3N1-060655-1
Certified Performance Curve (Future)	K3N1-060655-1
Certified Performance Curve (Present)	K3N1-060655-2
Certified Performance Curve (Future)	K3N1-060655-2
Setting Plan	SK3N1-060655
Material List	K3N1-060655
Sectional Drawing	24LYA1934-59
Technical Data	K3N1-060655
Fenwal Temperature Probe	6.30.5 (2 Pages)
Fenwal Control Data	3.24.9 (4 Pages)
Fenwal Instruction Manual	3.24.E (4 Pages)
Spare Parts Furnished	---
Installation, Operation & Maintenance Manual	5400

### SECTION II. PARRISH SHAFTING & NON-REVERSE CLUTCH ASSY

Shaft Assy Installation Drawing	CUS-1250
Shaft Assy W/Back Stop Clutch	103413-03908
Non-Reverse Clutch Guard	183-009-001
Installation & Maintenance Instructions	1ML-482

### SECTION III. MARATHON ELECTRIC MOTOR

Certification Data	---
Dimension Print	A-SS511484
Performance Data	PF385
Connection Diagram	A-EE7317
Motor Instruction Manual	SB-181

PUMP NO K3N1-060655-0 STAGES ONE SIZE-FIGURE 8-B5415  
 TESTED 4/30/86 DRIVER DYNO-150 MTR IMPELLER TAKE5GX  
 IMPELLER DIAMETER 17.9"  
 RPM AS NOTED

Certified Correct By *[Signature]* 4/86

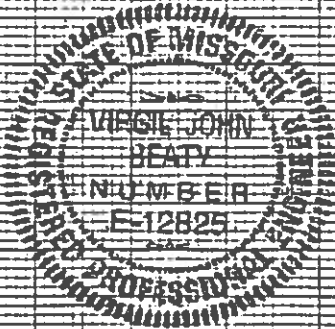

*Virgil John Beatty*  
*5/2/86*

CERTIFIED PUMP PERFORMANCE CURVE

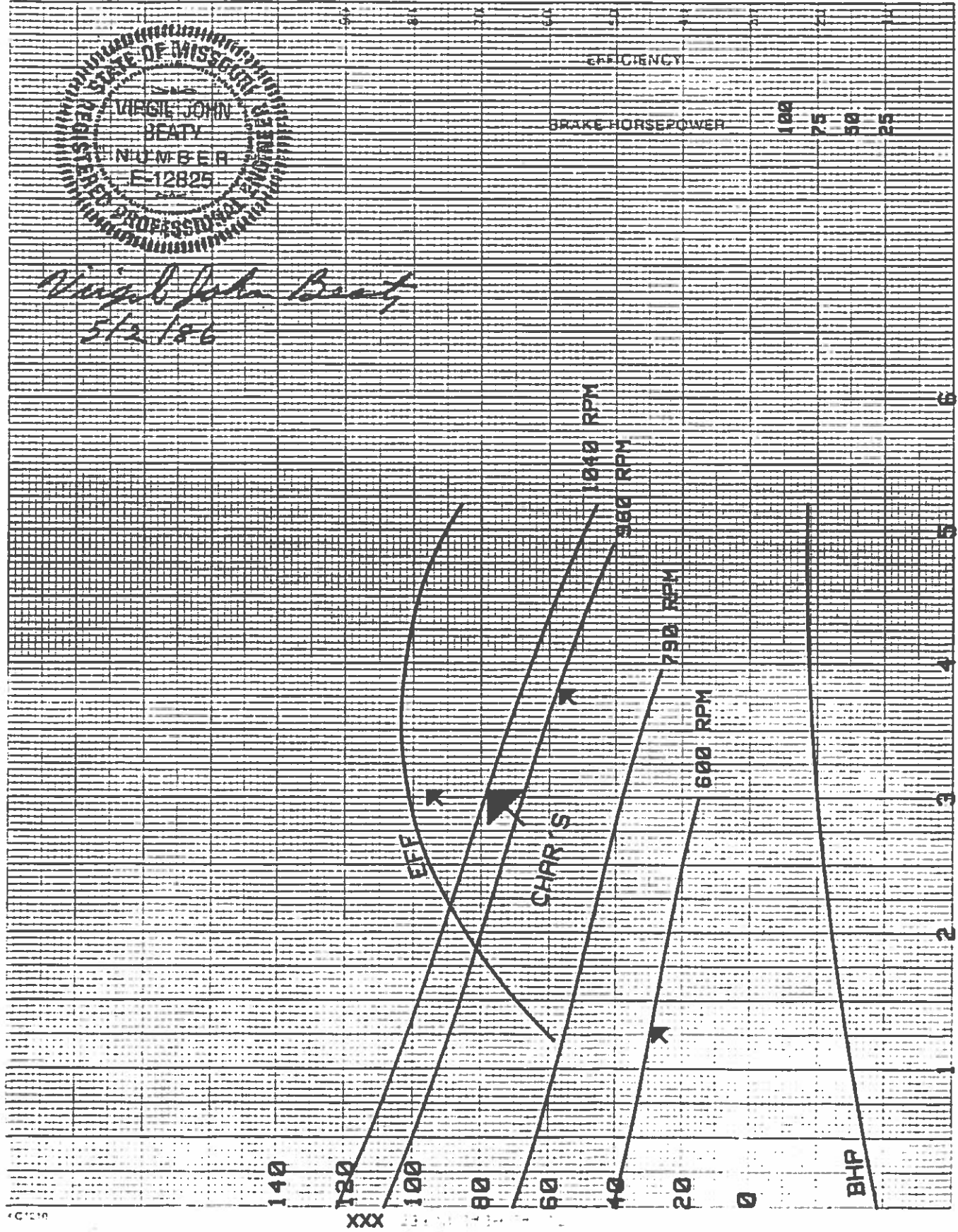

"PRESENT"

U.S. GALLONS PER MINUTE X 1000

PUMP NO **K3N1-060655-0** STAGES **ONE** SIZE-FIGURE **8-B5415**  
 TESTED **4/30/86** DRIVER **DYNO-150 MTR** IMPELLER **TAKE5GX**  
 IMPELLER DIAMETER **17.9"**  
 RPM **AS NOTED**

Certified Correct By *[Signature]* 4/86



*Virginia John Beatz*  
*4/2/86*

CERTIFIED PUMP PERFORMANCE CURVE

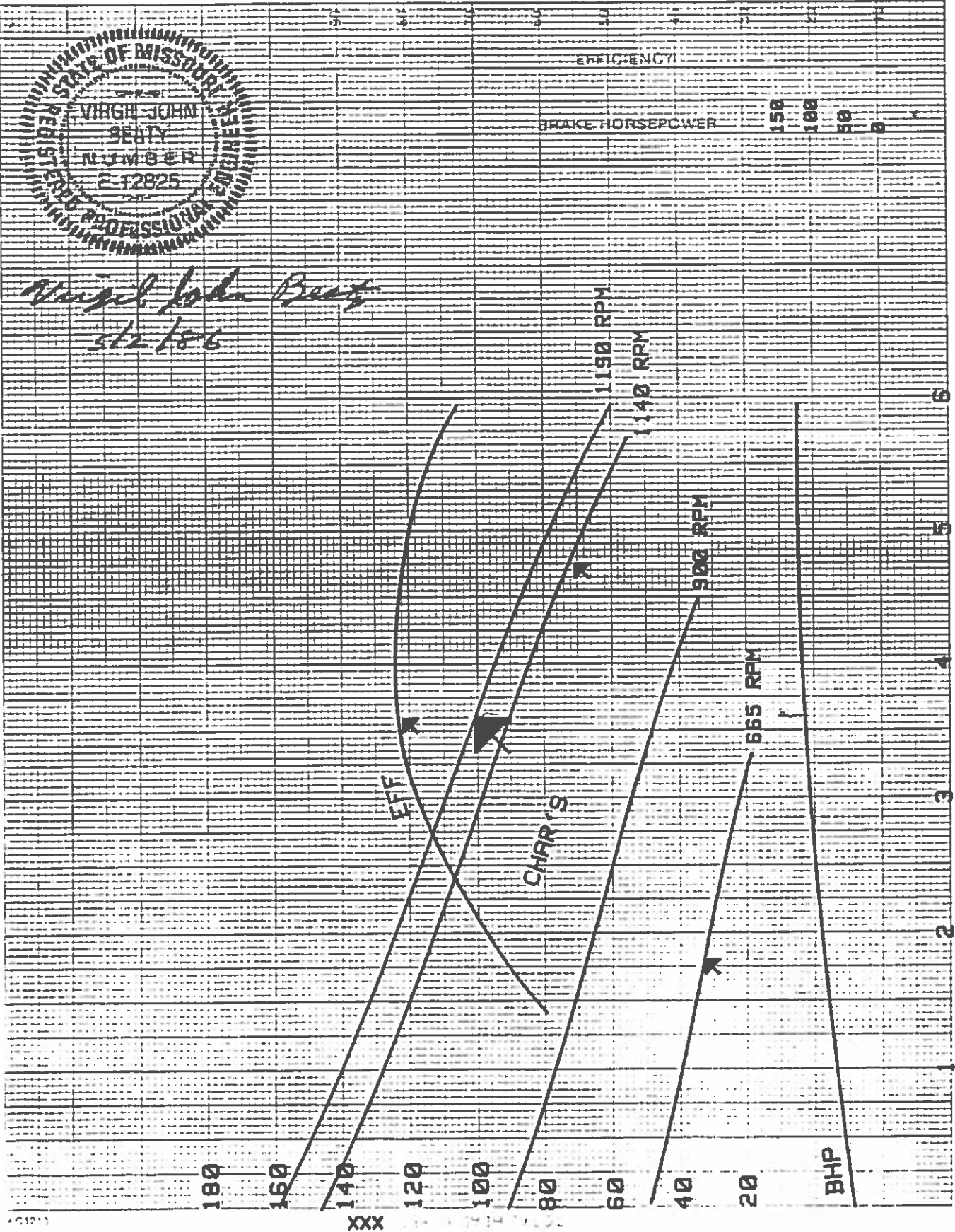

U.S. GALLONS PER MINUTE X 1000

"FUTURE"

PUMP NO **K9N1-060655-1** STAGES **ONE** SIZE-FIGURE **8-B5415**  
 TESTED **4/30/86** DRIVER **DYNO-150 MTR** IMPELLER **TAKE5GX**  
 IMPELLER DIAMETER **17.9"**  
 RPM **AS NOTED**

Certified Correct By *John Beat* 4/86



*Virginia John Beat*  
5/2/86

EFFICIENCY

BRAKE HORSEPOWER

100  
75  
50  
25

"PRESENT"

CERTIFIED PUMP PERFORMANCE CURVE

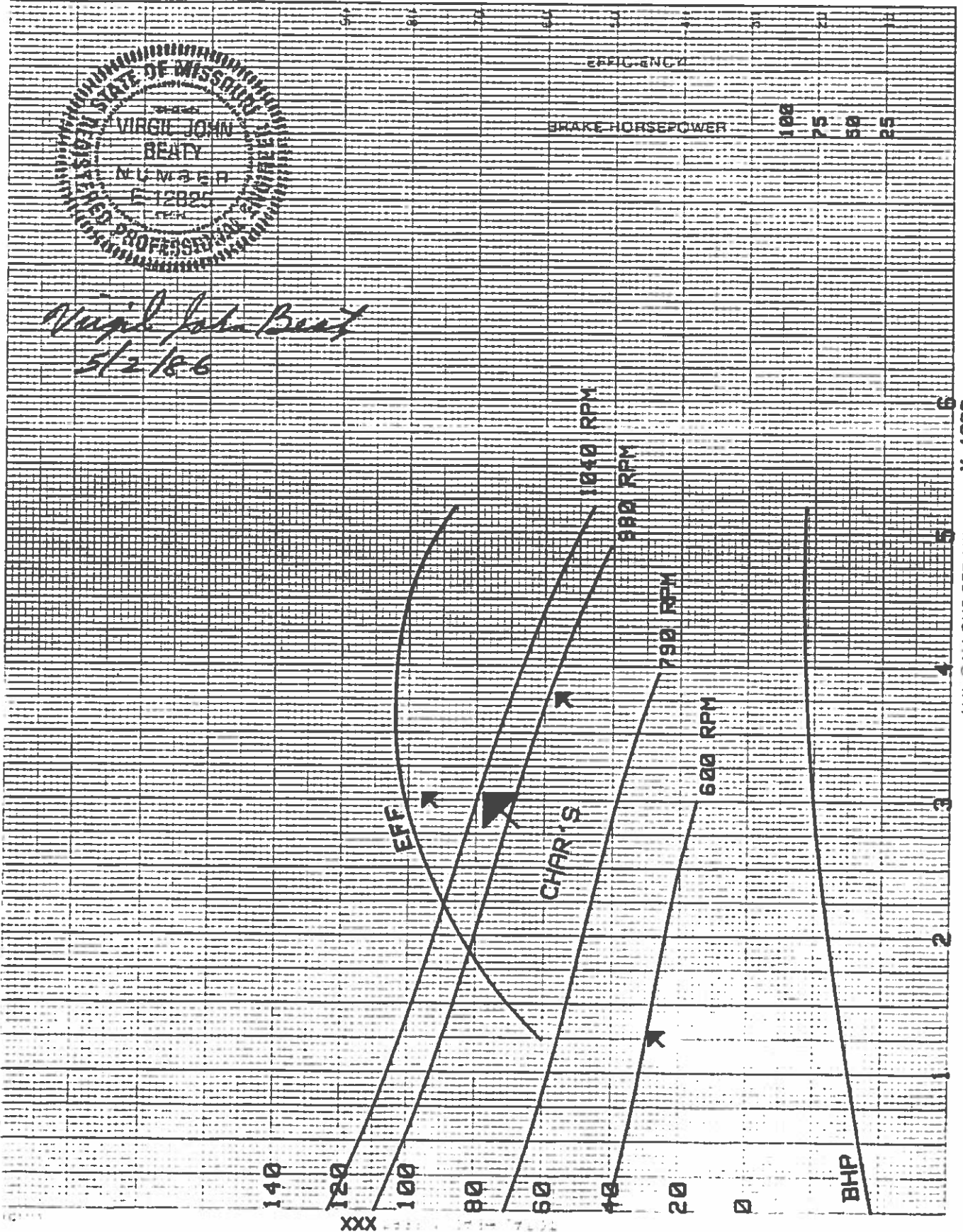

U.S. GALLONS PER MINUTE X 1000

PUMP NO **K3N1-060655-2** STAGES **ONE**  
TESTED **4/30/86** DRIVER **DYNO-150\_MTR**

SIZE FIGURE **8-B5415**  
IMPELLER **TAKE5GX**  
IMPELLER DIAMETER **17.9"**  
RPM **AS NOTED**

Certified Correct By *[Signature]* **4/86**



*Virgil John Beatz*  
*5/2/86*

CERTIFIED PUMP PERFORMANCE CURVE

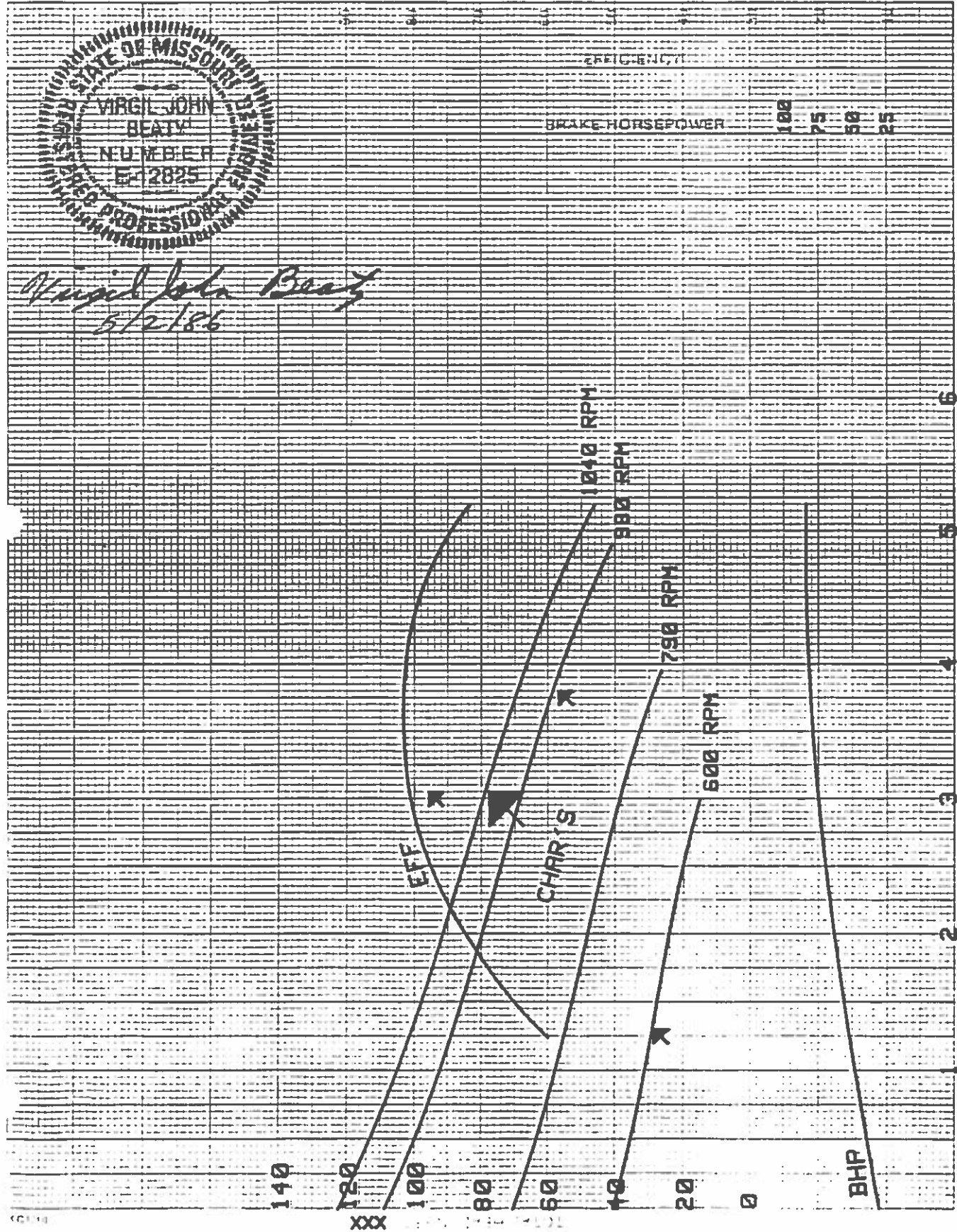

U.S. GALLONS PER MINUTE X 1000

PUMP NO **K3N1-060655-2** STAGES **ONE** SIZE-FIGURE **8-B5415**  
 TESTED **4/30/86** DRIVER **DYNO-150 MTR** IMPELLER **TAKE5GX**  
 IMPELLER DIAMETER **17.9"**  
 RPM **AS NOTED**

Certified Correct By *[Signature]* **4/86**

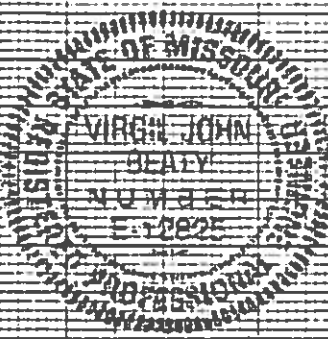

*Virginia John Beatty*  
*5/2/86*

CERTIFIED PUMP PERFORMANCE CURVE

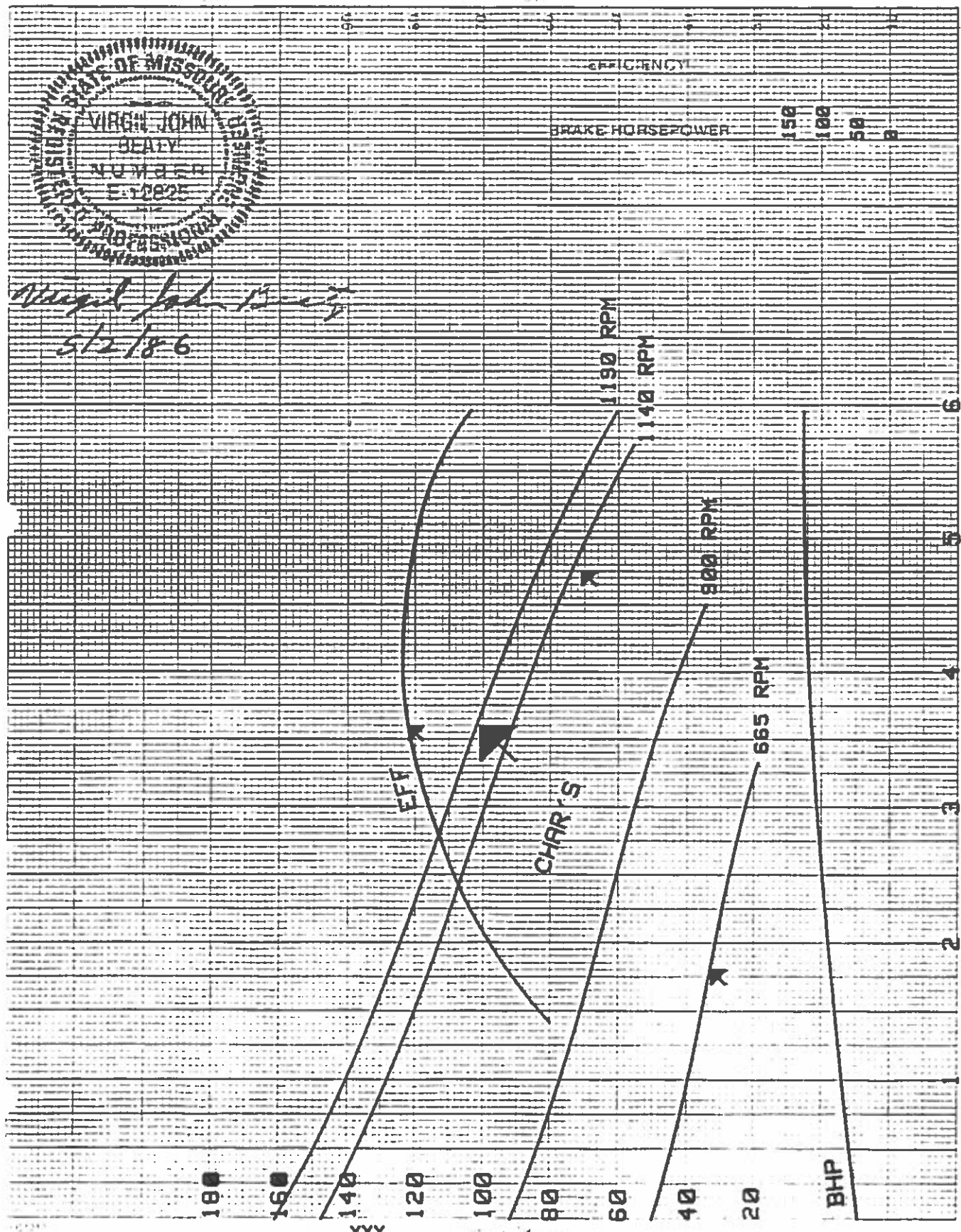

U S GALLONS PER MINUTE X 1000



NOTE: CONTRACTOR TO VERIFY ALL ELEVATIONS.

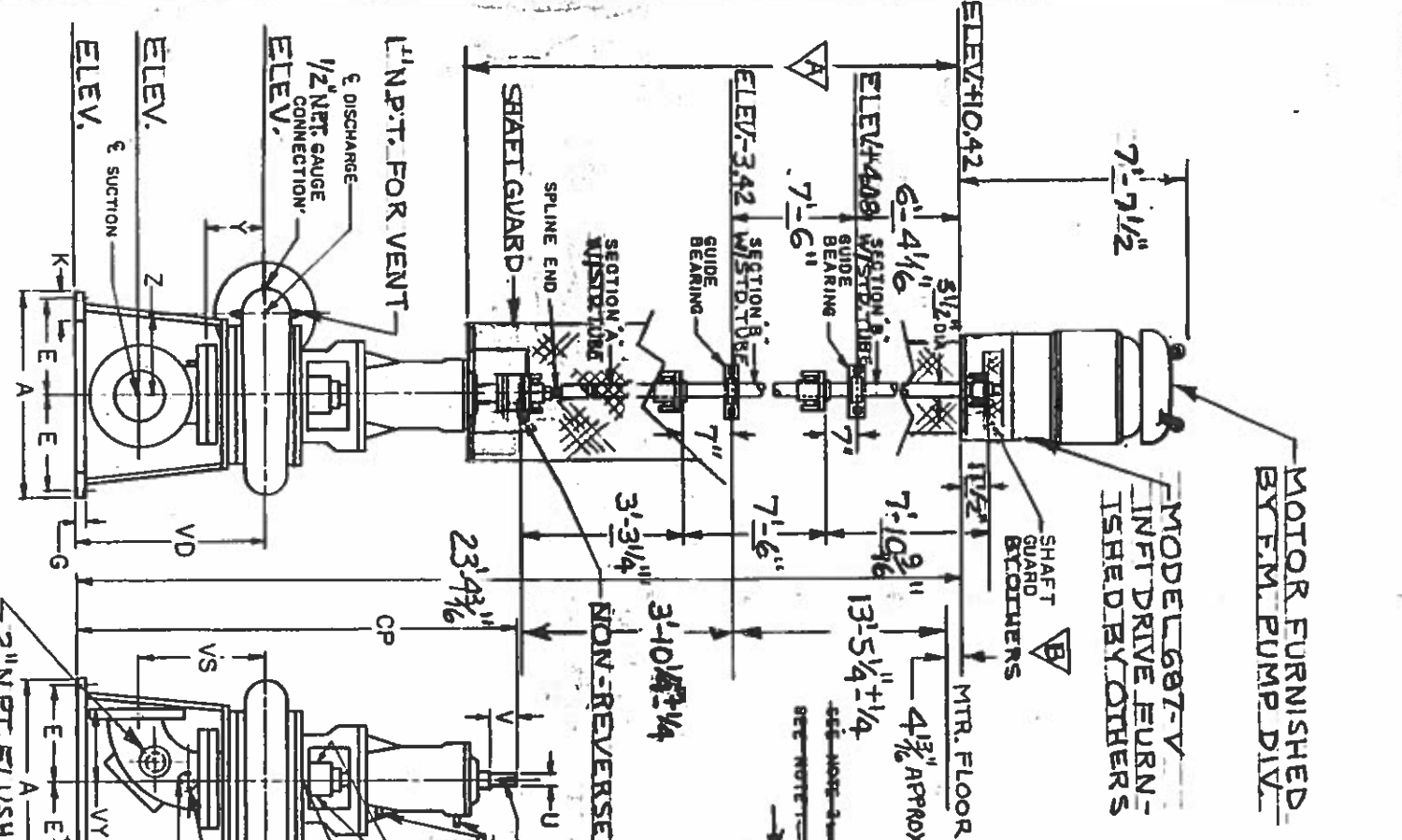

PUMP SIZE	PUMP FRAME SIZE	SUCT. SIZE	DISCH. SIZE	A	E	G	H	K	U	V	X	Y	Z	VD	VS	VY	KEYWAY	CP
2'BS411	20	2	2	20	8 1/4	1/2	1 1/8	1 3/8	2 1/4	6 1/2	4	5 1/4	18	9	4 1/2	5 1/8 x 5/32	40 1/2	
3'BS411	20	3	3	20	8 1/4	1/2	1 1/8	1 3/8	2 1/4	7 1/4	4 1/4	5 3/4	18 1/4	10 1/4	5 1/2	5 1/8 x 5/32	40 1/2	
4'BS411	20	4	4	20	8 1/4	1/2	1 1/8	1 3/8	2 1/4	8 1/2	4 1/2	6 1/8	18 1/2	11 1/2	5 3/4 x 5/32	41 1/2		
4'BS41C	20	4	4	20	8 1/4	3/4	1 1/8	1 3/8	2 1/4	8 1/2	4 1/2	6 1/8	18	12	10 1/4	5 1/8 x 5/32	41	
4'BS41C	20	6	4	20	8 1/4	3/4	1 1/8	1 3/8	2 1/4	8 1/2	4 1/2	6 1/8	18	12	10 1/4	5 1/8 x 5/32	39 1/2	
2'BS412	20	2	2	20	8 1/4	3/4	1 1/8	1 3/8	2 1/4	9	5	7 1/4	17 3/8	10 1/4	5 1/2	5 1/8 x 5/32	39 1/2	
4'BS412	20	4	4	20	8 1/4	3/4	1 1/8	1 3/8	2 1/4	10	5 1/4	7 3/4	17 3/8	11 1/8	5 1/2	5 1/8 x 5/32	40 1/2	
4'BS412C	20	4	4	20	8 1/4	3/4	1 1/8	1 3/8	2 1/4	10	5 1/4	7 3/4	17 3/8	11 1/8	5 1/2	5 1/8 x 5/32	41	
3'BS413	30	3	3	24	10 3/4	1"	1 1/8	1 3/8	1 7/8	11	5 1/2	7 3/4	23 3/4	11	5 1/2	1/2 x 1/4	51 1/2	
4'BS413	30	4	4	24	10 3/4	1"	1 1/8	1 3/8	1 7/8	11	5 1/2	7 3/4	23 3/4	11	5 1/2	1/2 x 1/4	52 1/2	
4'BS413C	30	4	4	20	8 1/4	3/4	1 1/8	1 3/8	1 7/8	11	5 1/2	7 3/4	23 3/4	11	5 1/2	1/2 x 1/4	46 1/8	
5'BS413	30	5	5	24	10 3/4	1"	1 1/8	1 3/8	1 7/8	12	6 1/4	9	24 1/4	12 3/4	5 1/2	5 1/8 x 5/32	59 3/8	
6'BS413	30	6	6	24	10 3/4	1"	1 1/8	1 3/8	1 7/8	12	6 1/4	9	24 1/4	12 3/4	5 1/2	5 1/8 x 5/32	60 1/2	
4'BS414	40	5	4	30	13 3/4	3/4	1 1/8	1 3/8	2 1/4	14 3/4	7 3/4	10 3/8	25 1/8	14 3/4	7 1/2	5 1/8 x 5/16	59 3/8	
5'BS414	40	6	5	30	13 3/4	3/4	1 1/8	1 3/8	2 1/4	16	8	11 1/2	26 3/8	14 7/8	10	5 1/8 x 5/16	60 1/2	
6'BS414	40	8	6	30	13 3/4	3/4	1 1/8	1 3/8	2 1/4	17	8 3/8	12 3/8	26 1/2	16 3/8	8	5 1/8 x 5/16	60 1/2	
8'BS414	40	10	8	30	13 3/4	3/4	1 1/8	1 3/8	2 1/4	18	9 1/8	14	27	18 1/8	11	5 1/8 x 5/16	61 1/2	
8'BS444	40	10	8	30	13 3/4	3/4	1 1/8	1 3/8	2 1/4	16	8 3/8	14 1/8	27	18 1/8	11	5 1/8 x 5/16	61 1/2	
8'BS445	60	10	8	42	19	1"	1 1/8	1 3/8	2 3/8	21	10 1/2	19 3/4	33 3/8	19 1/2	11	5 1/8 x 5/16	67 1/2	
10'BS445	60	10	8	42	19	1"	1 1/8	1 3/8	2 3/8	24	11	21 3/8	34 3/8	22	11	5 1/8 x 5/16	68 1/2	
5'BS446	40	8	5	30	13 3/4	3/4	1 1/8	1 3/8	2 3/8	14	9 1/2	12 3/8	25 1/8	18 1/4	9	5 1/8 x 5/16	59 3/8	
6'BS446	60	10	6	42	19	1"	1 1/8	1 3/8	2 3/8	14 1/2	12 3/8	34 3/8	25 3/8	11	11	5 1/8 x 5/16	67 1/2	
8'BS446	60	12	8	42	19	1"	1 1/8	1 3/8	2 3/8	14 1/2	12 3/8	34 3/8	25 3/8	12 1/2	12	5 1/8 x 5/16	67 1/2	

**WARNING**  
DO NOT OPERATE THIS MACHINE WITHOUT PROTECTIVE GUARDS IN PLACE. ANY OPERATION OF THIS MACHINE WITHOUT PROTECTIVE GUARDS CAN RESULT IN SEVERE PERSONAL INJURY.

2" NPT FLUSHING CONNECTIONS BOTH SIDES

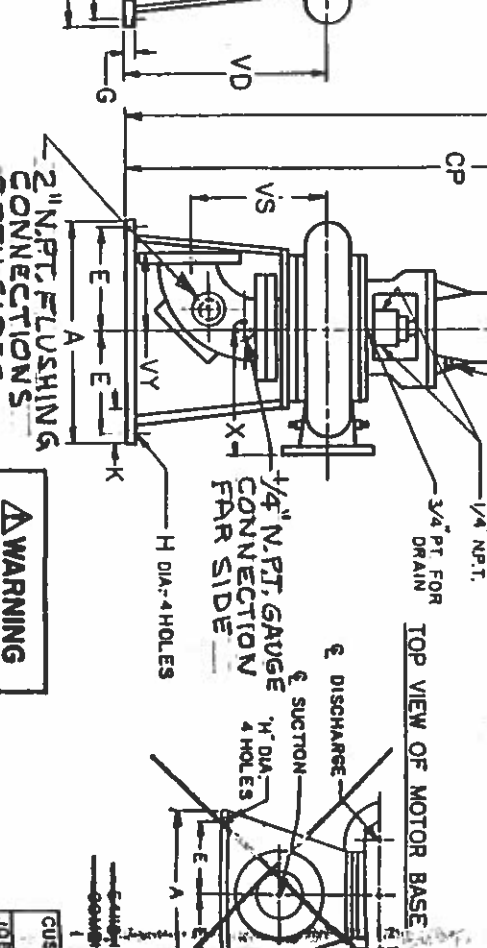

GUIDE BEARING DIMENSIONS

SHAFT DIA.	SHAFT SERIES	A	B	C	D	E	F	G	H	J
1 3/8	V27	1 3/8	6	4 3/4	1 3/8	9/16	3/4	3 1/8	1 3/8	3 3/8
1 7/8	V37	1 7/8	6	4 3/4	1 3/8	9/16	3/4	3 1/8	1 3/8	3 3/8
1 5/8	V41	1 5/8	6	4 3/4	1 3/8	9/16	3/4	3 1/8	1 3/8	3 3/8
1 1/2	V61	1 1/2	6	4 3/4	1 3/8	9/16	3/4	3 1/8	1 3/8	3 3/8

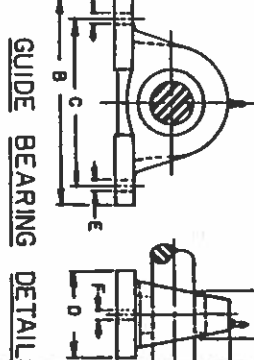

FLANGE DIMENSIONS

NOM. SIZE	FLG. O.D.	NO. OF BOLTS	BOLT DIA.	BC DIA.
2	5	4	5/8	4 3/4
3	7 1/2	4	5/8	6
4	9	8	5/8	7 1/2
5	10	8	3/4	8 1/2
6	11	8	3/4	9 1/2
8	13 1/2	8	3/4	11 3/4
10	15	12	7/8	14 1/4

DRAWINGS ILLUSTRATES THE DISCHARGE POSITIONS AVAILABLE FOR CW AND CCW ROTATION WHEN VIEWED FROM DRIVER END OF PUMP POSITIONS NO 1 AND 9 ARE CONSIDERED STANDARD. POSITION CIRCLED FURNISHES THIS ORDER. THIS DRAWING ILLUSTRATES THE CLOCKWISE POSITION NO 1

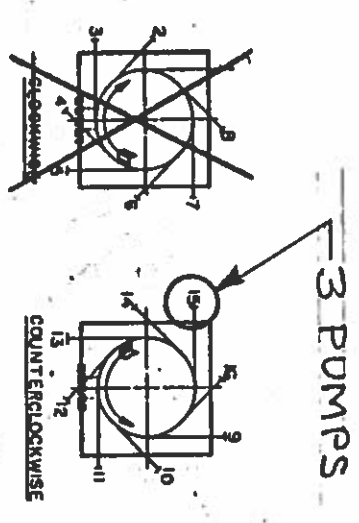

NOTES:  
1. THIS MACHINE IS TO BE INSTALLED IN A BUILDING OR UNDER COVER.  
2. THIS MACHINE IS TO BE INSTALLED ON A CONCRETE FOUNDATION.  
3. DIMENSIONS ARE AS SHOWN UNLESS OTHERWISE SPECIFIED.  
NOTE:  
INSTALL SHAFTING PER THE UNIVERSAL DRIVE SHAFT MANUFACTURERS RECOMMENDATIONS, WITH AN ANGULAR OFFSET.

CUSTOMER: ROSS-ARACO CORP. P.O. 2191  
JOB NAME: BRIDGE PUMP STA. CONTR. W/W/L-PS-1, CAPE MAY CO, NJ  
PUMP SIZE: 8 X 10 BR415  
MOTOR TYPE: MARATHON VSS, DP 2-SPEED  
PHASE: 3  
CYCLES: 60  
VOLTS: 480  
FRAME: 508P  
DATE: 5/11/85

PROPRIETARY INFORMATION

REV	DESCRIPTION	DATE	BY	CHK	APP'D
1	CHANGED ELEVATIONS & SHAFT LENGTHS	5/11/85	RS	RS	

B5410 AND B5410C  
VERTICAL DRY-PIT NON-CLOG PUMPS  
MATERIAL SPECIFICATIONS

K3N1-060655  
ROSS-ARACO CORP. PO 2191  
CAPE MAY COUNTY, NJ  
MUNICIPAL UTIL. AUTHORITY  
CONTRACT MW/L-PS-1  
SEC. 15B, PG. 15B-20,  
ARTICLE 2.10 D  
ROSEMARY ROAD PUMPING STATION

5411 Thru 5418  
STANDARD FITTED (SF) PUMPS

REF. NO.	DESCRIPTION	MATERIAL	(1) SPECIFICATION
1	IMPELLER	CAST IRON	A48-CL30 1 1/2-3% NI
4	SHAFT	MANGANESE STEEL	A108-C1141
9	CAPSCREW, IMPELLER	STEEL, STAINLESS	A193 CL2 B8
9A	WASHER, IMPELLER	STEEL, STAINLESS	AISI-416
10	RING, WATER SEAL	TEFLON	TEFLON
14	SLEEVE, SHAFT	STAINLESS STEEL	<del>A743-CA-40</del> 450-484 BHN
15	BASE	FABRICATED STEEL (2)	A283 GR. D AND A7 OR A36
<del>16</del>	<del>GLAND HALF</del>	<del>CAST IRON</del>	<del>A48-CL30</del>
30	VOLUTE	CAST IRON	A48-CL30 1 1/2-3% NI
33	FRONTHEAD	CAST IRON	A48-CL30 1 1/2-3% NI
34	ADAPTER, FRAME	CAST IRON	A48-CL30 1 1/2-3% NI
44	SUCTION ELBOW	CAST IRON	A48-CL30 1 1/2-3% NI
90	FRAME	CAST IRON	A48-CL30
102	KEY, IMPELLER	STEEL	AISI-1018
126A	DEFLECTOR, INNER	RUBBER	NEOPRENE
126B	DEFLECTOR, OUTER	RUBBER	NEOPRENE
139	HOUSING THRUST BEARING	CAST IRON	A48-CL30
140A	SEAL, INNER GREASE	-	-
154	GASKET, ELBOW	TAG BOARD	D1170-G3111
156	GASKET, VOLUTE	TAG BOARD	D1170-G3111
159	COVER, THRUST BEARING HOUSING	CAST IRON	A48-CL30
159A	SEAL, OUTER GREASE	-	-
161	LOCKNUT, BEARING	STEEL	SAE BOLT STEEL
162	LOCKWASHER, BEARING	STEEL	AISI-1215
163	BEARING, INNER	STEEL	- (1)
168	BEARING, OUTER	STEEL	- (2)
202	COVER, VOLUTE HANDHOLE	CAST IRON	A48-CL30 1 1/2-3% NI
203	GASKET, VOLUTE HANDHOLE COVER	RUBBER	-
206A	RETAINER, INNER GREASE	STEEL	-
206B	RETAINER, OUTER GREASE	STEEL	-
212	PACKING	SYNTHETIC PACKING GRAPHITE IMREGNATED	
272	KEY, COUPLING	STEEL	AISI-1018
290	COVER, HANDHOLE	CAST IRON	A48-CL30 1 1/2-3% NI
291	GASKET, HANDHOLE	RUBBER	-
<del>167</del>	<del>BALANCE WEIGHT, IMPELLER</del>	<del>CAST IRON</del>	<del>A48-CL30</del>
<del>164</del>	<del>SUCTION ELBOW (BARE CONFORMATION)</del>	<del>CAST IRON</del>	<del>A48-CL30</del>

FYN-0801-07926

T-60 E14B

NATIONAL 416047

NATIONAL 471837

NTN 5219  
NSK 7315B46 ORG

OPTIONS TO BASIC PUMPS

REF. NO.	DESCRIPTION	MATERIAL	SPECIFICATION
<del>1</del>	<del>IMPELLER</del>	<del>BRONZE</del>	<del>B145(838)</del>
16	WEAR RING, FRONTHEAD	STAINLESS STEEL	AISI-416 300-350 BHN
17	WEAR RING, IMPELLER	STAINLESS STEEL	AISI-416 190-241 BHN
19	GLAND HALF	BRONZE	B145(838)
<del>21</del>	<del>SOLID GLAND</del>	<del>STEEL</del>	<del>A108-C1141</del>
<del>436</del>	<del>MECHANICAL SEAL</del>	<del>-</del>	<del>-</del>

1. ALL MATERIAL DESIGNATIONS ARE ASTM UNLESS OTHERWISE NOTED, AND ARE FOR DESCRIPTION OF CHEMISTRY ONLY.  
2. PLATE IS A283 GR. D AND CHANNEL IS A7 OR A36.

DRAWN BY  
 DATE 9/1/84  
 CHECKED BY W.A.T.  
 DATE 9/84  
 ENGINEERING APPROVAL  
 DATE 7/84  
 MARKETING APPROVAL  
 DATE  
 DRAWING NUMBER 24LYA1934-59

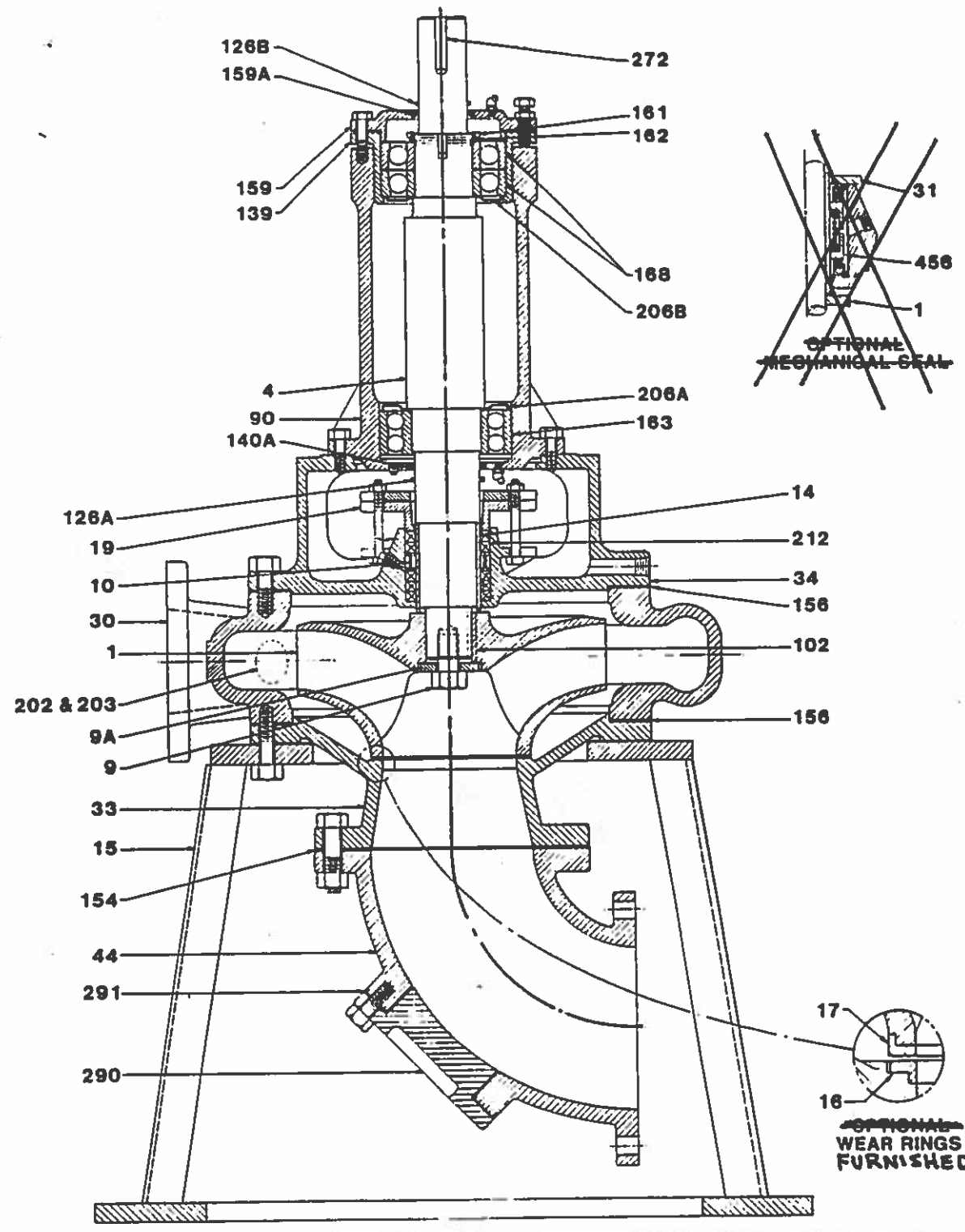

REV.	DATE	ECN NO.
2	9/1/84	EC1-12528

K3N1-066655  
 ROSS-ARACO CORP. PO 2191  
 CAPE MAY COUNTY, NJ  
 MUNICIPAL UTIL. AUTHORITY  
 CONTRACT MW/L-PS-1  
 SEC. 15B, PG. 15B-28,  
 ARTICLE 2.10 D  
 ROSEMARY ROAD PUMPING STATION

 Fairbanks Morse  
 Colt Industries Pump Division  
**SECTIONAL**  
 8" ~~85415~~  
~~85415~~  
**T60 FRAME**  
 SIZE DWG. C NO. 24LYA1934-59

B5410  
VERTICAL DRY-PIT NON-CLOG PUMPS  
BASIC PUMP TECHNICAL DATA

	B5411, K			B5412, K			B5413, K			
	T20	T20	T20	T20	T20	T20	T30	T30	T30	T30
Frame Size	2	3	4	2	3	4	3	4	5	6
Pump Size	2	3	4	2	3	4	3	4	5	6
Suction Size	2	3	4	2	3	4	3	4	5	8
Impeller Face to Suction Cover Nominal Clearance	.015	.015	.020	.015	.015	.020	.015	.020	.020	.025
Volute Cleanout Diameter	None	1½	2	None	2½	2¾	2½	2¾	4½	4¾
Suction Elbow Cleanout Diameter	2	3	4	2	3	4	3	4	5	6
Volute Priming or Air Vent Tap Size	¼	¼	¼	¼	¼	¼	¼	¼	¼	¼
Gauge Connection (NPT)										
Discharge	¼	¼	¼	¼	¼	¼	¼	¼	¼	¼
Suction	¼	¼	¼	¼	¼	¼	¼	¼	¼	¼
Maximum Hydrostatic Test, PSI	65	65	65	90	90	90	125	125	125	125
Maximum Casing Working, PSI	45	45	45	60	60	60	85	85	85	85
Maximum Operating Temperature, °F	150	150	150	150	150	150	150	150	150	150
Minimum Diameter Opening to Install Pump (Inches)	28	30	32	30	32	34	36	40	40	40
Shipping Weight (Lbs.)	260	290	400	260	300	470	550	650	720	740
Minimum Casing Thickness	⅜	⅜	⅜	⅜	⅜	⅜	⅜	⅜	½	½

	B5414				B5415		B5416		
	T40	T40	T40	T40	T60	T60	T40	T60	T60
Frame Size	4	5	6	8	8	10	5	6	8
Pump Size	4	5	6	8	8	10	5	6	8
Suction Size	5	6	8	10	10	12	8	10	12
Impeller Face to Suction Cover Nominal Clearance	.020	.020	.025	.025	.025	.030	.020	.025	.025
Volute Cleanout Diameter	2¾	3½	4¾	4¾	5½	4¾	3¾	5½	5½
Suction Elbow Cleanout Diameter	5	5	6	6	6	6	6	6	6
Volute Priming or Air Vent Tap Size	¾	¾	1	1	1	1	¾	1	1
Gauge Connection (NPT)									
Discharge	¼	¼	¼	¼	½	½	¼	¼	¼
Suction	¼	¼	¼	¼	¼	¼	¼	¼	¼
Maximum Hydrostatic Test, PSI	150	115	115	115	115	115	190	225	150
Maximum Casing Working, PSI	100	75	75	75	75	75	125	150	100
Maximum Operating Temperature, °F	150	150	150	150	150	150	150	150	150
Minimum Diameter Opening to Install Pump (Inches)	46	48	50	52	68	70	48	58	68
Shipping Weight (Lbs.)	1060	1190	1250	1410	2650	2670	1260	1900	2650
Minimum Casing Thickness	⅜	½	½	½	¾	¾	⅜	¾	¾

	T20	T30	T40	T60
Frame Size				
Shaft Diameter:				
at Impeller	1½	1½	2½	2¾
at Sleeve	1½	2	2¾	3½
at Thrust Bearing	1.969	2.756	2.953	2.953
at Radial Bearing	1.969	2.559	3.740	3.740
between Bearings	2¾	3¾	4	4
at Coupling	1¾	1¾	2¾	2¾
Center to Center of Bearings	8¾	11	14½	13¾
Thrust Bearing No.	6310	6314	5315	7315
Radial Bearing No.	6310	6313	6219	5219
Stuffing Box:				
O.D. Sleeve	1¾	2½	3	3¾
I.D. Box	2¾	3½	4	4¾
Box Depth	2¾	3½	3¾	3¾
Size Packing	¾	¾	¾	¾
Rings Packing per Box	5	5	5	5
Seal Cage Width	¾	¾	1	1

K3N1-966655  
ROSS-ARACO CORP. PO 2191  
CAPE MAY COUNTY, NJ  
MUNICIPAL UTIL. AUTHORITY  
CONTRACT MW/L-PS-1  
SEC. 15B, PG. 15B-20,  
ARTICLE 2.10 D  
ROSEMARY ROAD PUMPING STATION

1. All dimensions are in inches.

**COUPLING TYPE**

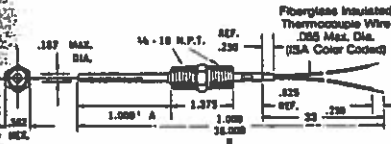

**CARTRIDGE TYPE**

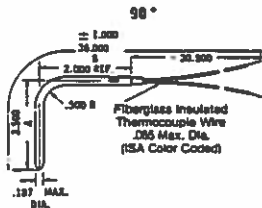
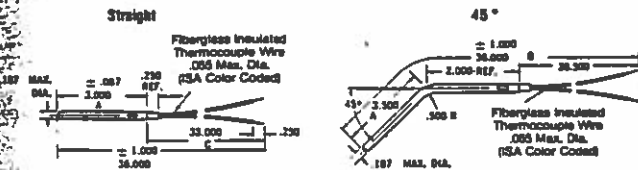

**BAYONET TYPE**

chart on page 2 for insertion depths.

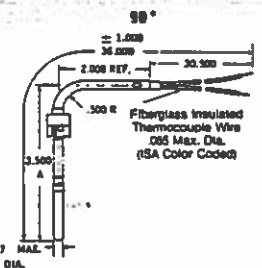
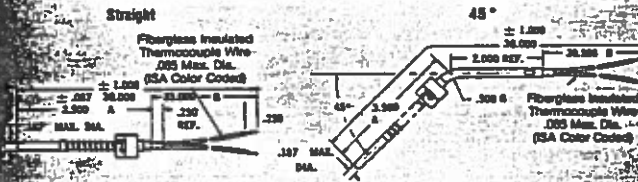

**ADJUSTABLE INSERTION DEPTH PROBE**

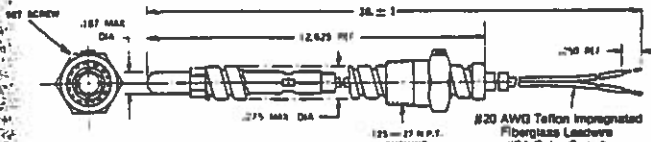

Fits insertion depths of 1/2 to 10 inches with standard 12" cable. Install bushing, insert thermocouple probe to desired depth and tighten set screw in bushing.

The 0.187 diameter probes are designed for insertion into 0.191 (#11) Inch diameter drilled holes. Bayonet style probes require 0.261 diameter drilled hole. Adjustable insertion depth probes require 0.290 diameter drilled hole.

# SERIES 53-1 and 53-3 THERMOCOUPLE PROBES

**GENERAL INFORMATION**

Fenwal Probes are precise temperature sensing devices manufactured of the highest grade materials to provide maximum performance and reliability. The Cartridge, Bayonet and Coupling Type probes are available for use with Fenwal Thermocouple Controllers. For special probes — consult factory.

Tip Style: Closed end — grounded

Probe Size & Material: .187" dia., 316 Stainless Steel (.187" dia. Inconel available. See Special Feature 86).

Lead Wire: 20 gauge fiberglass insulated. Standard commercial tolerance of 3/4%.

ISA Color Coded:

- Copper/Constantan — BLUE/RED with BLUE Tracer
- Iron/Constantan — WHITE/RED with WHITE Tracer
- Chromel/Alumel — YELLOW/RED with YELLOW Tracer

Thermocouple Material & Temperature Range:

- Copper/Constantan ..... -200 to +400 °F
- Iron/Constantan ..... 0 to 1200 °F
- Chromel/Alumel ..... 0 to 2500 °F

Probe Lengths: Standard lengths shown.

(Refer to Special Feature 84 for extended probes in 1/2" increments.)

**Caution: If probes are to be used in open gas flame of highly corrosive environments above 1800 °F — consult factory.**

CARTRIDGE TYPE (For Compression Fittings See Mod. 141)		
Temperature Range	Catalog No.	ISA Type
<b>Straight</b>		
-200 °F to +400 °F	53-111206-000	T
0 °F to 1200 °F	*53-111206-001	J
0 °F to 2500 °F	*53-111206-002	K
<b>45°</b>		
-200 °F to +400 °F	53-111207-100	T
0 °F to 1200 °F	53-111207-101	J
0 °F to 2500 °F	53-111207-102	K
<b>90°</b>		
-200 °F to +400 °F	53-111207-200	T
0 °F to 1200 °F	53-111207-201	J
0 °F to 2500 °F	53-111207-202	K
COUPLING TYPE		
-200 °F to +400 °F	53-121202-000	T
0 °F to 1200 °F	*53-121202-001	J
0 °F to 2500 °F	53-121202-002	K

BAYONET TYPE		
Temperature Range*	Catalog No.	ISA Type
<b>Straight</b>		
-200 °F to +400 °F	53-131207-000	T
0 °F to 800 °F	*53-131207-001	J
0 °F to 800 °F	53-131207-002	K
<b>45°</b>		
-200 °F to +400 °F	53-131207-100	T
0 °F to 800 °F	53-131207-101	J
0 °F to 800 °F	53-131207-102	K
<b>90°</b>		
-200 °F to +400 °F	53-131207-200	T
0 °F to 800 °F	53-131207-201	J
0 °F to 800 °F	53-131207-202	K
Adjustable Insertion Depth Probes		
-200 °F to +400 °F	53-631204-000	T
0 °F to 1200 °F	*53-631204-001	J
0 °F to 1200 °F	53-631204-002	K

\*Maximum temperature limited to upper range indicated for each style shown.

Above 1800 °F use of well is recommended • NORMALLY STOCKED — Available for Immediate Shipment

**BAYONET ADAPTORS**  
Must be Ordered Separately.  
Applicable to bayonet probes only.

Catalog Number	Material	Diagram
06-126113-000	stainless	
06-126111-000	steel	

**BAYONET PROBES INSERTION DEPTH CHART**  
Applicable to 53-13 probes only.

K3N1-060655  
ROSS-ARACO CORP. PO 2191  
CAPE MAY COUNTY, NJ  
MUNICIPAL UTIL. AUTHORITY  
CONTRACT MW/L-PS-1  
SEC. 15B; PG. 15B-20;  
ARTICLE 2.10 D  
ROSEMARY ROAD PUMPING STATION

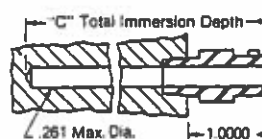

ADAPTOR PART NOS. 06-126111-000,  
06-126113-000  
(See above)

## MODIFICATIONS

### Mod. 121 — Extended Lead Wire Lengths

Modification Number	Lead Wire Material	Length (ft.)	
		Min.	Max.
131A	Copper/Constantan	0	170
131B	Iron/Constantan	0	150
131C	Chromel/Alumel	0	85

**IMPORTANT** — All Fenwal lead wire lengths are measured from the end of the thermocouple probe. Standard probes are provided with 36" lead wires total length. The amount of wire extending from the end of the probe is determined by the length of the probe.

Determine material and total lead wire length and specify appropriate Mod. No. on order. Example: Mod. 131C, 87 inches total length.

### Mod. 132 — BX Cable Connector with Terminals

To be combined with Mod. 135 Armored Cable or Mod. 140 S.S. Braid. Specify Mod. Number on order.

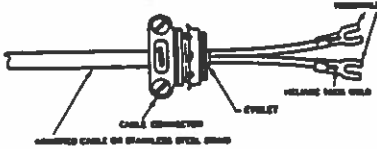

Mod. No.	Lead Wire Material	SA Type	Temperature Range
132A	Copper/Constantan	T	-200 to +400°F
132B	Iron/Constantan	J	0 to 1200°F
132C	Chromel/Alumel	K	0 to 2500°F

### Mod. 134 — Polarized Plug (male)

The addition of plug or jack assy. and cable adaptor to thermocouple wire. Specify Mod. Number on order.

**NOTE:** Plug may be shipped unassembled. When required specify Part Number\* on order not Mod. Number. Mod. 134 also applicable to Mods. 135 and 140.

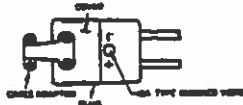

MAX. AMBIENT  
TEMP. 350°F

Mod. No.	Lead Wire Material	SA Type	PART NO.* (shipped assembled)
134A	Copper/Constantan	T	06-114539-001
134B	Iron/Constantan	J	06-114539-002
134C	Chromel/Alumel	K	06-114539-003

### Polarized Jack (female)

When desired female jack assy. and cable adaptor can be provided. Specify part number on order.



MAX. AMBIENT  
TEMP. 350°F

Mod. No.	Lead Wire Material	SA Type	PART NUMBER
134D	Copper/Constantan	T	06-114525-001
134E	Iron/Constantan	J	06-114525-002
134F	Chromel/Alumel	K	06-114525-003

## HOW TO ORDER

1. Decide on the type of probe required — cartridge, bayonet or coupling.
2. Next, select the probe configuration, straight, 45°, 90° or adjustable insertion depth probe.
3. Choose the probe temperature range that covers the temperature range of your Fenwal Thermocouple Controller and add appropriate catalog number to your order.
4. When a Modification and/or Special Feature is desired, include the number(s) on your purchase order.

**NOTE:** When Modifications and/or Special Features are ordered a new catalog number may be assigned for complete probe assembly.

### Mod. 135 — Stainless Steel Armored Cable

The addition of armored cable over thermocouple lead wire.

**NOTE:** Factory will provide a minimum of 3" free lead wire beyond armored cable unless otherwise specified.

Example: #53-111206-000 Cartridge Probe Lead Length is 33".

LESS Minimum Free Lead Wire 3"  
Maximum Armored Cable Length (L) 30"

Specify Mod. Number and armored cable length (L) on order.

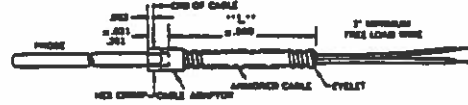

**NOTE:** To extend armored cable and lead wire of adjustable insertion depth probes, use Special Feature 53-982005-0XX.

### Mod. 140 — Stainless Steel Braid

The addition of stainless steel braid over thermocouple lead wire.

**NOTE:** Factory will provide a minimum of 3" free lead wire beyond S.S. Braid unless otherwise specified.

Example: #53-111206-000 Cartridge Probe Lead Length is 33".

LESS Minimum Free Lead Wire 3"  
Maximum S.S. Braid Length (L) 30"

Specify Mod. Number and S.S. Braid Length (L) on order.



### Mod. 141 — Compression Fitting (For Cartridge Type Probes Only)

When required, compression fittings can be provided for liquid or gastight applications. This modification is shipped unassembled for installation in the field.

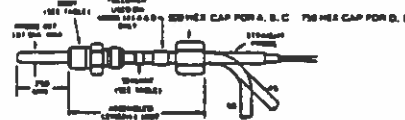

Mod. No.	Body Size (NPT)	Sealant Material	Fitting Material	Maximum Operating Temperature	Maximum Working Pressure	Assembly Torque	Assembled Length
141A	1/2-27	Teflon	S.S.	to 500°F	3000 psi	45 ft. lbs.	1.187
141B†	1/2-27	Lava	S.S.	to 1850°F	5000 psi	55 ft. lbs.	1.187
141C†	1/2-27	Brass	Brass Nickel Pl.	to 800°F	2000 psi	55 ft. lbs.	1.234
141D	1/2-18	Teflon	S.S.	to 500°F	3000 psi	45 ft. lbs.	2.000
141E†	1/2-18	Lava	S.S.	to 1850°F	5000 psi	55 ft. lbs.	2.000

†This fitting cannot be reused.

### Mod. 164 — Variable Length Cable & Connector Assembly



	Iron/Const.	Chromel/Alumel	Copper/Const.
Cable & Jack	164A	164E	164J
Braid & Jack	164B	164F	164K
Cable & Plug	164C	164G	164L
Braid & Plug	164D	164H	164M

**NOTE:** Standard extension 1 foot. Added extension in 1 foot increments. Specify dimension L.

## SPECIAL FEATURES

#### S.F. 53-982005-XXX — Extended Armored Cable and Lead Wire.

(Applicable to Adjustable Insertion Depth Probes only).

Extension of both armored cable and lead wire in 1 inch increments. Indicate extended length required in last three digits.

Example: S.F.53-982005-024 = 24 inch length.

#### S.F. 84 — Extended Probe Length

Extension of probe length in 1/2" increments. Specify length on order, as total probe length. Example: S.F.84, 8.500 inch overall length.

**NOTE:** Probes ordered with this S.F. will be assigned a new catalog number by Fenwal.

#### S.F. 86 — Inconel Shell

Substitute Inconel shell material, except for bayonet type probes.

# FENWAL INCORPORATED

Division of Kidde, Inc.

**KIDDE**

Ashland, Massachusetts 01771

# FENWAL<sup>®</sup>

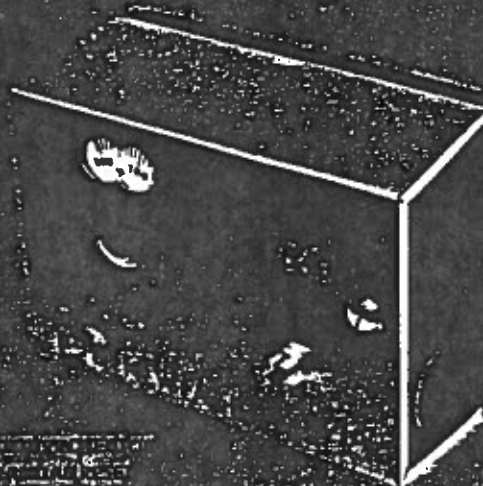
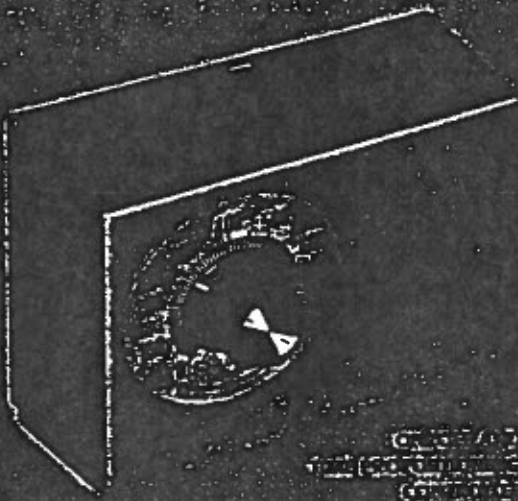

## SERIES 543

### THERMOCOUPLE SENSING TEMPERATURE CONTROLLERS

#### FEATURES

- UL COMPONENT RECOGNIZED 9A
- LOW COST
- FIELD SELECTABLE POWER INPUTS
- SINGLE POLE OR DOUBLE POLE HEAVY DUTY RELAY OUTPUTS
- OUTPUT TO DRIVE SOLID STATE RELAYS
- LINE AND LOAD VOLTAGE COMPENSATION
- FM APPROVED HIGH LIMIT

#### APPLICATIONS

- Food Processing
- Plastics Processing
- Packaging Machinery
- Laboratory Equipment
- Dip tanks
- Degreasers
- Plating equipment
- Cooking equipment
- OSHA-related high limit protection
- Automatic Solder Devices

#### GENERAL INFORMATION

Fenwal's low cost Series 543 thermocouple-sensing instruments are offered in four models: On/Off or Time Proportioning Controllers and two High Temperature Limit Protectors with manual reset. Each model features selectable input voltages. Control models have heavy duty relay or solid state switching outputs. Limit models have relay output only.

The On/Off and Proportioning Control models are available with case and cover, or "stripped" for custom installation. Local or remote set point adjust can be ordered for each configuration.

The FM approved High Limit Model has a concealed set point adjustment with a visible dial plus a local Reset Button. Available with case and cover only.

## GENERAL INFORMATION (Continued)

The UL approved High Limit Model has a factory-fixed set point with an optional remote or local Reset Button. Available with case and cover or "stripped" for custom installation.

The High Limit models are designed to satisfy OSHA-related requirements for overheat protection. In the event of an overheat condition, the protector will trigger an alarm or shut down the process. Reset cannot be ac-

complished until the process temperature drops below the set point and the manual reset button is depressed. To satisfy FM and/or UL requirements, the protectors must be powered from the same source as the controller or heater. FM approved and UL recognized limits reset automatically on power outage.

The Series 543 operates with standard thermocouples. See Table II for temperature ranges and thermocouple types.

## SPECIFICATIONS

### CONTROL MODES

- On/Off
- Time Proportioning
- UL Recognized Fixed Set Point High Limit
- FM Approved Adjustable Set Point High Limit

### INPUT POWER

- 120, 208 or 240VAC  $\pm 10\%$ , 50-60Hz, field selectable.
- UL High Limit is 120/208 or 120/240VAC only.

### OUTPUT

- Heavy duty SPDT or DPDT relay rated 10A @ 120 VAC, 5A @ 208 or 240VAC, resistive, each contact.
- Pilot Duty: 250VA, 240VAC maximum.

Output to drive solid state relay: non isolated output, 20VDC max into 1500 ohms, 5VDC minimum into 200 ohms.

SPDM 25A relay rated 25A @ 120VAC, resistive.

### POWER DISSIPATION

- 5 watts  $\pm 1$  watt, nominal.

### AMBIENT TEMPERATURE LIMITS

- Operating: 32 to 135°F. (0 to 60°C)
- Storage: -25 to 165°F. (-30 to 75°C)

### SET POINT ACCURACY (at 77°F ambient and nominal voltage)

- Proportioning and On/Off models -  $\pm 1\%$  typical,  $\pm 1.5\%$ , maximum, of dial span for remote set point models;
- $\pm 3\%$  of dial span for local set point models.
- Adjustable set limit models (FM) —  $\pm 3\%$  of dial span.
- Fixed set limit models (UL) —  $\pm 1\%$  of dial span ( $\pm 1.5\%$  of dial span in 0-700°F range).
- Accuracy based on millivoltage for National Bureau of Standards Thermocouple Characteristics.

### AMBIENT TEMPERATURE EFFECTS (CONTROL ACCURACY)

- Control point will remain within  $\pm 1\%$  of dial span with ambient changes from nominal to 32°F (0°C) and 135°F (60°C).

### CYCLE TIME (Proportioning Models)

- Relay output — approximately 15 seconds nominal at 50% power.
- Output to drive solid state relay — approximately 2 seconds.

### LINE & LOAD VOLTAGE EFFECTS (CONTROL ACCURACY)

On/Off and Proportioning models — Control point will remain within  $\pm 0.5\%$  of dial span with line and load voltage changes of  $\pm 10\%$  from nominal at any bandwidth setting. High limit models — Control point will remain within  $\pm 0.25\%$  of dial span with voltage change of  $\pm 10\%$  from nominal.

### BANDWIDTH (Proportioning Models)

Adjustable 1 to 5% of dial span, except 0.5 to 3% of dial span on 0-2000°F and -20-1100°C ranges.

### DIFFERENTIAL (On/Off Models)

2°F, typical.

### VIBRATION

Meets requirements of MIL-STD 202D, Method 201.

### LEAD-BREAK PROTECTION

#### Proportioning and On/Off Models

Relay will de-energize upon an open thermocouple (500K ohms or greater) with the case grounded, terminal TC+ or TC- grounded or floating and with either polarity of line voltage applied to the instrument power terminals.

Reverse action upon open thermocouple (cooling load deenergized) can be supplied. See special features.

#### High Limit Models

Relay energized upon an open thermocouple.

### THERMOCOUPLE LEAD LENGTH

Accuracy shall remain within specification for thermocouple lead length up to the equivalent of 150 ohms resistance.

### TERMINALIZATION

Instrument power and remote pot: .250" quick connect.

Load connections: .187" quick connect (supplied).

Thermocouple: #8 screws.

Solid state switch output: .093 quick-connects (supplied).

25 amp output: #14 AWG lead wires, 6 inches long.

### WEIGHT

With case and cover—1 pound 10 ounces (735 grams).

Without case and cover—10 ounces (280 grams).

**SPECIFICATIONS SUBJECT TO CHANGE WITHOUT NOTICE**



**TABLE I  
INSTRUMENT TYPES AND MODEL NUMBERS**

CONTROLLER TYPE	SPDT RELAY 10/5A	OUTPUT TO DRIVE SOLID STATE SWITCH	SPOM RELAY 25A	DPDT RELAY 10/5A	DESCRIPTION
On/Off	*54-301111-XXX *54-301113-XXX	54-301211-000 54-301213-000	*54-301311-XXX *54-301313-XXX	54-301411-000 54-301413-000	w/o case & cover, local set point w/o case & cover, remote set point
	*54-301121-XXX *54-301123-XXX	54-301221-000 54-301223-000	54-301321-XXX 54-301323-XXX	54-301421-000 54-301423-000	w/case & cover local set point w/case & cover remote set point
FM Approved High Limit	54-302121-XXX			54-302421-000	w/case & cover, local set point
Factory Fixed Control Models Specified	*54-302114-XXX			54-302414-000	w/o case & cover, remote reset, 120/240VAC input
	*54-302115-XXX			54-302415-000	w/o case & cover, remote reset, 120/208VAC input
	*54-302124-XXX			54-302424-000	w/case & cover, local reset, 120/240VAC input
	*54-302125-XXX			54-302425-000	w/case & cover, local reset, 120/208VAC input
	*54-302134-XXX *54-302135-XXX			54-302434-000 54-302435-000	w/case & cover, remote reset, 120/240VAC input w/case & cover, remote reset, 120/208VAC input
Proportioning	*54-303111-XXX *54-303113-XXX	54-303211-000 54-303213-000		*54-303411-000 *54-303413-000	w/o case & cover, local set point w/o case & cover, remote set point
	*54-303121-XXX *54-303123-XXX	54-303221-000 54-303223-000		*54-303421-000 *54-303423-000	w/case & cover, local set point w/case & cover, remote set point

\*Recognized under the Component Recognition Program of the Underwriters Laboratories, Inc.

†Relay de-energized below set point on limit models only.

## HOW TO ORDER

1. Select desired controller from Table I.
2. Select temperature range from Table II and add appropriate three digit suffix to catalog number.  
**NOTE:** For UL Recognized (factory fixed) High Limit units, add desired fixed temperature setting to order.
3. Add appropriate modification or special feature number.
4. Order appropriate thermocouples from Fenwal Brochure 6.30. See Table II for compatible ISA type thermocouples.

**TABLE II  
TEMPERATURE RANGES AND THERMOCOUPLE TYPES**

CONTROLLER TYPE	TEMP. RANGE	THERMOCOUPLE TYPE	SUFFIX NO.
On/Off & Proportioning	0-400°F	J	-102
	0-800°F	J	-103
	0-1000°F	J	-104
	0-2000°F	K	-106
	-20 to 430°C	J	-203
	-20 to 1100°C	K	-206
FM Approved Limit	0-800°F	J	-103
	0-1000°F	J	-104
	0-2000°F	K	-106
	-20 to 430°C	J	-203
	-20 to 1100°C	K	-206
UL High Limit Models	0-700°F	T	-113
	0-1200°F	J	-108
	0-2000°F	K	-106

\*Recognized under the Component Recognition Program of the Underwriters Laboratories, Inc.

## MODIFICATIONS

54-992045-XXX — Three lead wires soldered to remote set point potentiometer. Specify length desired in feet as last three digits in Modification number.  
Example: 54-992045-004 = 4 feet.

54-992054-XXX — Leadwires soldered to remote reset fixed limit models. Reset button and terminals shipped unattached unless this modification is ordered. Specify length desired as above.

## SPECIAL FEATURES

54-982020-001 — Reverse lead-break protection (On/Off and Proportioning Controllers only).

54-982030-X0X — Millivolt input in place of thermocouple. (On/Off and Proportioning Controllers only). Available Ranges: 0-1 mv; 0-10 mv; 0-50 mv. Consult factory for additional specifications. When ordering specify millivolt range with special feature number. Case and cover models supplied with 0-10 arbitrary dial.

54-982024-X0X — Adjustable switching differential 1-20°F. (On/Off models only).

# OUTLINE DIMENSIONS

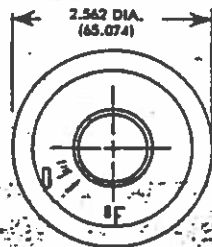
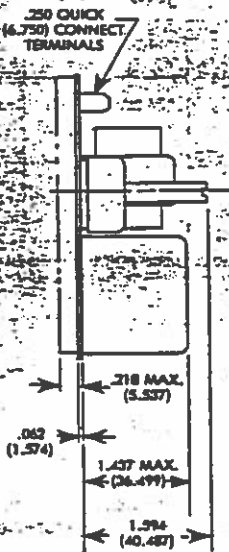
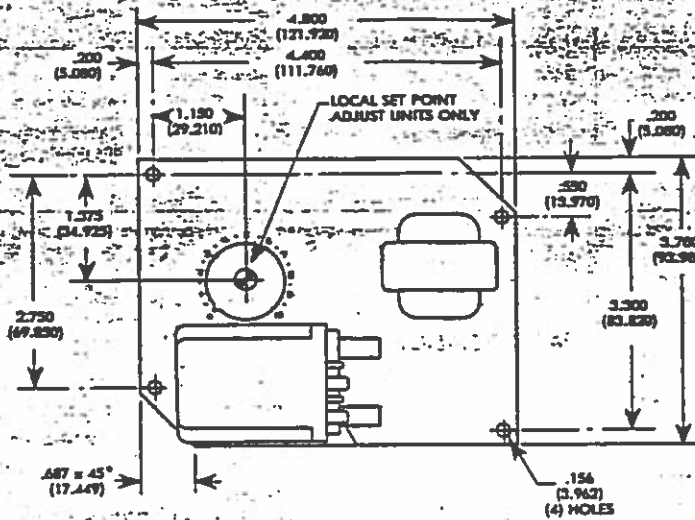
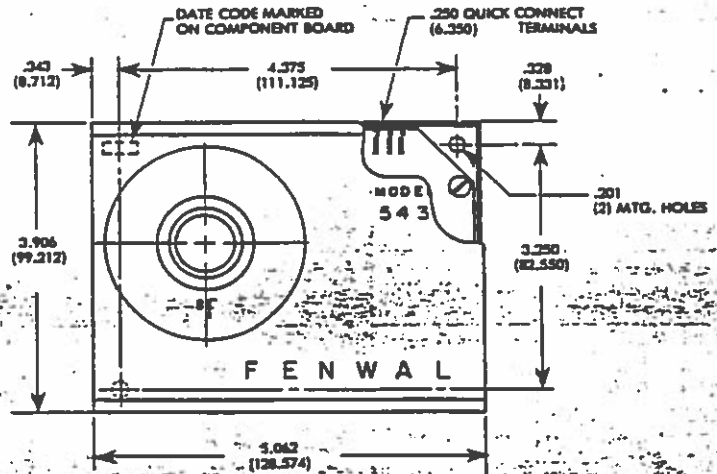
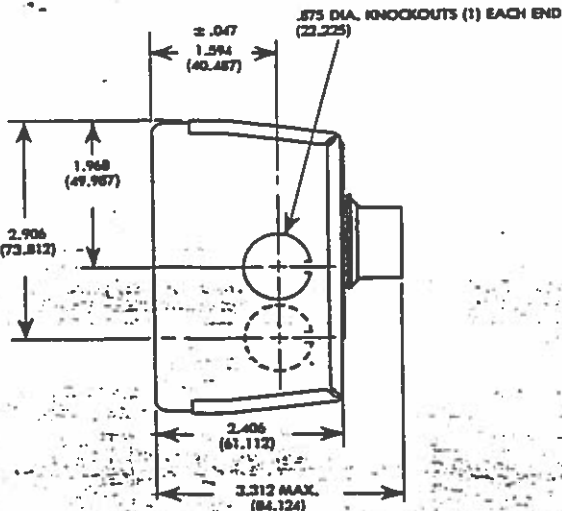

For Remote Potentiometer Units

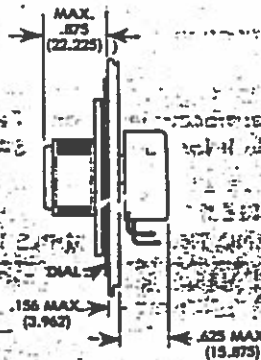

(Metric Dimensions are in Parentheses)

# FENWAL INCORPORATED

Division of Kidde, Inc.

**KIDDE**

Ashland, Massachusetts 01721



# FENWAL®

## SERIES 543

THERMOCOUPLE SENSING  
TEMPERATURE CONTROLLERS

## INSTALLATION INSTRUCTIONS

### DESCRIPTION

Fenwal's Series 543 thermocouple-sensing instruments are offered in four basic models: On/Off or Time Proportioning Controllers and two High Temperature Limit Protectors with manual reset. Each model features selectable input voltages. Control models have 2, 10 or 25 amp relay or solid state switching outputs. Limit models have 10 amp relay output only.

The High Limit models are designed to satisfy OSHA-related requirements for overheat protection. In the event of an overheat condition, the protector will trigger an alarm or shut down the process. Reset cannot be accomplished until the process temperature drops below the set point and the manual reset button is depressed. To satisfy FM and/or UL requirements, the protectors must be powered from the same source as the controller or heater. FM approved and UL recognized limits reset automatically on power outage.

The Series 543 operates with standard thermocouples. See Table II, Page 4 for temperature ranges and thermocouple types.

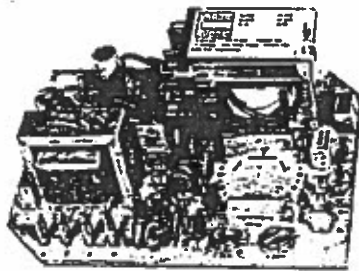
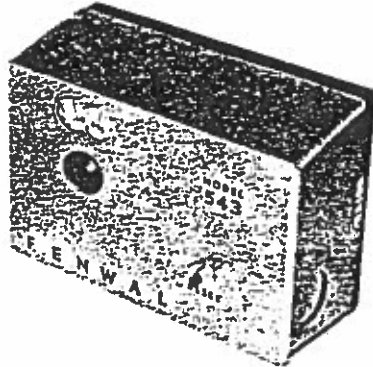

## INSTALLATION

### Mounting

#### Installation Procedure for Models with Enclosure (54-30XX2X-XOX)

Select location on panel or machine and lay out mounting holes per Figure 1. Remove front cover (loosen set screw and remove knob on units with external dial). Cover is secured by spring locking detents on each side. Align two holes in controller back plate with mounting holes on machine or panel and secure with appropriate #8 hardware. Do not replace cover until controller wiring is completed. On High Limit models remove cover carefully since manual reset button is wired to printed circuit board. Cover can be removed up to six inches from Controller.

#### Installation Procedure for Models without Enclosure (54-30XX1X-XOX)

Select location and lay out mounting holes per Figure 2. Use 3/8" spacers as standoffs for the controller printed circuit board. Align four holes on printed circuit board with mounting holes and secure with appropriate #6 hardware.

### Remote Set Point Installation Procedure

**WARNING:** Controller and set point adjust potentiometer have been carefully calibrated and matched. Ensure that the set point potentiometer packed with the control board is used. The numbers on the controller and potentiometer must match.

Drill two holes as indicated in Figure 5. Affix dial by removing paper from back and pressing against clean surface. Insert potentiometer shaft through larger hole, aligning anti-rotation tab with smaller hole. Secure with lock washer and nut. Rotate potentiometer shaft fully counterclockwise and align knob pointer with datum mark on dial. Secure knob by tightening set screw.

**NOTE:** A temperature limiting device should be incorporated into your system for added protection. Consult your Fenwal representative for recommendations.

## OUTLINE DIMENSIONS

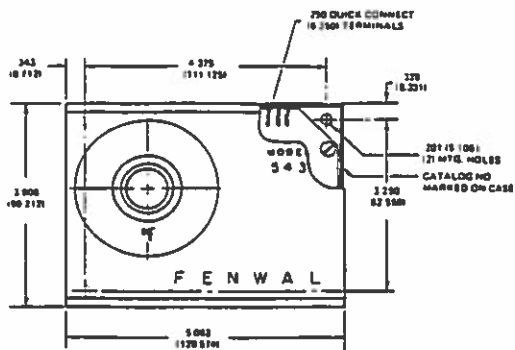

FIGURE 1

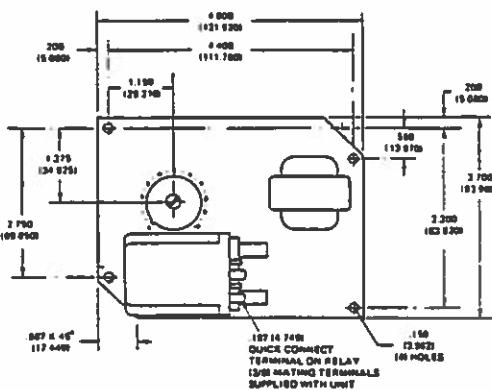

FIGURE 2

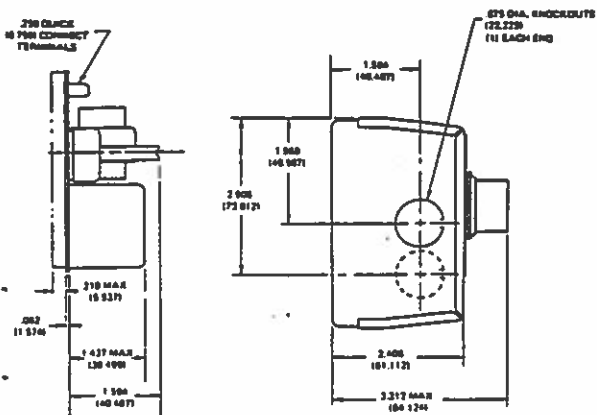

FIGURE 3

FIGURE 4

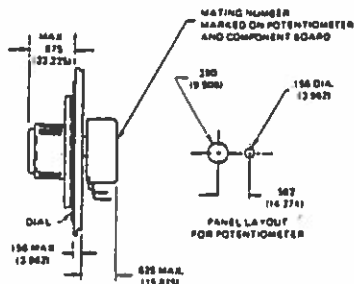

FIGURE 5

DIMENSIONS IN PARENTHESES ARE STATED IN MILLIMETERS

## WIRING

### Instrument Power

Remove appropriate knockouts. One .875" knockout is located on each side of the instrument case for power and thermocouple leads.

Wire in accordance with local codes. Cut and strip leads to appropriate length and attach 1/4" quick connect female terminals excluding thermocouple leads which attach directly to screw terminals.

Refer to Figures 7, 8 or 9 for appropriate wiring diagram.

### Load Power

Refer to Figures 10 thru 14 for appropriate output connections and wire accordingly, using factory supplied terminals (connect 25 amp. model directly to relay lead wires).

If controller output is to drive a solid state relay, the relay must have 3 to 32 VDC input.

### Agency Requirements

To satisfy agency requirements the Series 543 High Limit controller must be powered from the same source as the heater or Primary Controller. Follow wiring diagram in Figure 6.

### Remote Set Point

Each remote potentiometer and controller assembly has been calibrated at the factory to operate together. The potentiometer and the printed circuit board assembly have been stamped with matching numbers. These numbers must match for proper operation. Attach 1/4" quick connect female terminals to the ends of the leads. Connect lead from CW lug to terminal 5, lead from CCW lug to terminal 3 and center lug to terminal 4. (See Figures 7 and 15.)

### Remote Reset

Connect remote reset as shown in Figure 9, switch must be normally closed type.

### Sensor Connections

Connect negative (red) lead to terminal TC-. Connect positive (white, yellow or blue) lead to terminal TC+. Reverse connection of thermocouple leads will result in improper operation of controller unit.

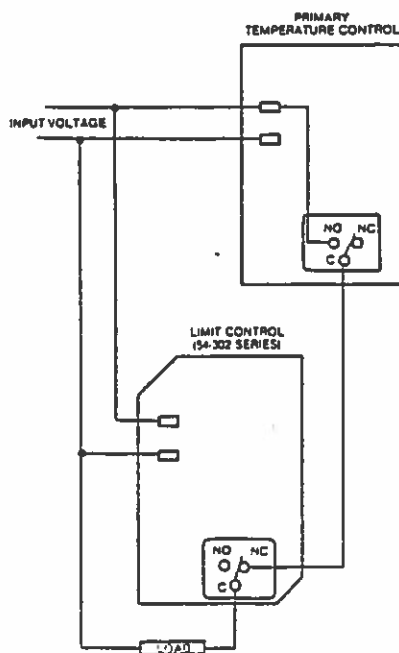
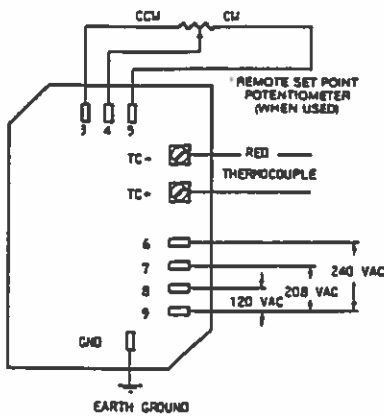

FIGURE 6

## WIRING DIAGRAMS



94-301XXX-XXX OR  
94-305XXX-XXX  
(ON/OFF OR TIME PROPORTIONING)

FIGURE 7

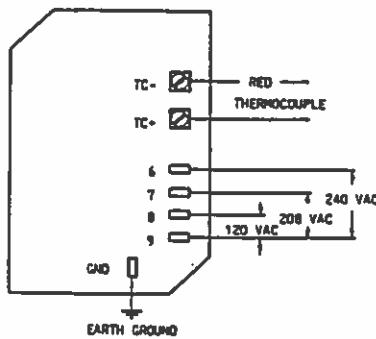

94-302121-XXX  
(FM HI LIMIT)

FIGURE 8

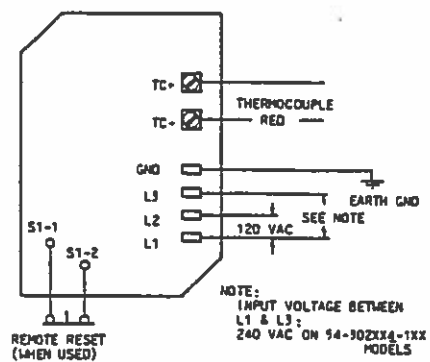

94-302XX4-1XX OR  
94-302XX5-1XX  
(U.L. HI LIMIT)

FIGURE 9

NOTE:  
INPUT VOLTAGE BETWEEN  
L1 & L3:  
240 VAC ON 94-302XX4-1XX  
MODELS  
208 VAC ON 94-302XX5-1XX  
MODELS

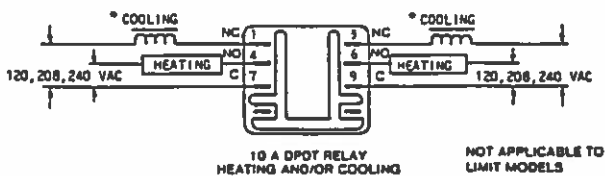

10 A DPDT RELAY  
HEATING AND/OR COOLING

NOT APPLICABLE TO  
LIMIT MODELS

FIGURE 10

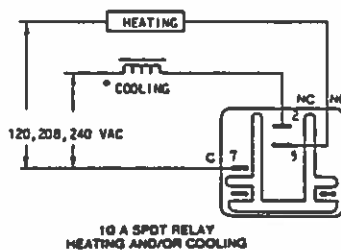

10 A SPDT RELAY  
HEATING AND/OR COOLING

FIGURE 11

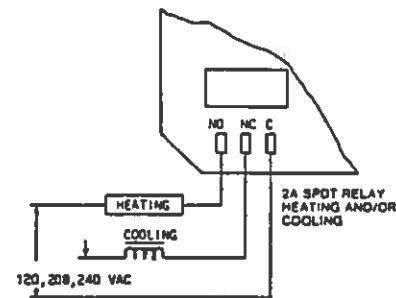

2A SPDT RELAY  
HEATING AND/OR  
COOLING

FIGURE 12

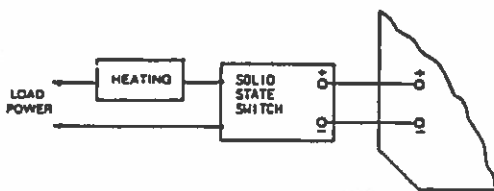

OUTPUT TO DRIVE  
SOLID STATE SWITCH  
HEATING ONLY

FIGURE 13

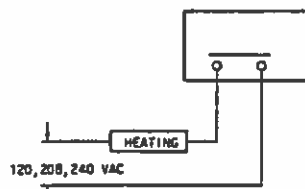

25A SPDM RELAY  
HEATING ONLY

FIGURE 14

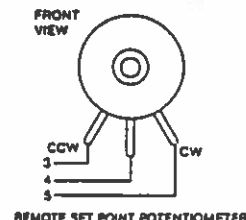

REMOTE SET POINT POTENTIOMETER

FIGURE 15

## OPERATION

### Set Point Adjustment

Set knob pointer to desired operating temperature; controller relay will cycle on/off when system reaches operating temperature. Use recessed screwdriver adjust to set temperature on High Limit models.

### Proportioning Adjustment

Proportioning models incorporate an adjustable bandwidth potentiometer on the printed circuit board which permits tuning of the controller to the system to minimize tem-

perature excursions. Factory setting is at mid-point of its rotational range, which will satisfy the requirements of most systems. To reduce bandwidth, rotate adjustment counterclockwise (CCW). To increase bandwidth, rotate adjustment clockwise (CW).

To obtain greatest system accuracy, measure the process temperature after system has reached set point. Loosen the knob set screw and align pointer with dial graduation corresponding to measured process temperature, then secure knob by tightening set screw.

## PROBE APPLICATION HINTS

Proper application of the thermocouple probe is important. The probe tip is the sensing element in the system and must be in direct contact with the process material to provide

optimum sensing accuracy. One inch immersion is usually satisfactory for either liquid or solids applications.

# THERMOCOUPLE CONNECTIONS

Refer to Table I and determine the positive (+) and negative (-) leads of the thermocouple.

TABLE I — LEAD WIRE IDENTIFICATION

ISA Thermocouple Type	ISA Color Code	Lead Wire Material	Temperature Range
J	White Red	+ Iron - Constantan	0-1200°F -20 - 430°C
K	Yellow Red	+ Chromel - Alumel	0-2000°F -20 - 1100°C
T	Blue Red	+ Copper - Constantan	0 - 700°F

NOTE: When using thermocouple lead wire in sizes other than 20 gauge, refer to Table III for the appropriate factor to determine the total resistance of the lead wire in use. Total resistance should not exceed 150 ohms to maintain controller specified tolerances.

TABLE II  
TEMPERATURE RANGES AND THERMOCOUPLE TYPES

Controller Type	Temp. Range	Thermocouple Type*	Suffix No.
On/Off & Proportioning	0-400°F	J	-102
	0-800°F	J	-103
	0-1000°F	J	-104
	0-2000°F	K	-108
	-20 to 430°C	J	-203
	-20 to 1100°C	K	-208
FM Approved Limit	0-800°F	J	-103
	0-2000°F	K	-108
	-20 to 430°C	J	-203
	-20 to 1100°C	K	-208
High Limit including UL models	0-700°F	T	-113
	0-1200°F	J	-108
	0-2000°F	K	-108

\* Thermocouple type must match controller catalog number suffix as listed above.

## CAUTION

The thermocouple probe is a precision sensor and should be handled with care during installation. Do not handle with pliers, force it into position, or apply excessive torque when installing threaded units. On installations where process temperature will exceed 1600°F, the probe should be protected with a well.

TABLE III — MULTIPLYING FACTOR FOR LEAD WIRE EXTENSIONS

Material	Wire Gauge								
	12	14	16	18	20	22	24	28	30
Ohms per double foot at 70°F									
Copper/Constantan	.047	.074	.117	.190	.297	.475	.754	1.92	3.04
Iron/Constantan	.054	.089	.137	.221	.350	.550	.870	2.261	3.568
Chromel/Alumel	.095	.147	.234	.380	.586	.940	1.49	3.81	6.05

TABLE IV — RECOMMENDED UPPER TEMPERATURE LIMITS FOR PROTECTED THERMOCOUPLES

Thermocouple Type	UPPER TEMPERATURE LIMIT FOR VARIOUS WIRE SIZES (AWG). DEG. F (DEG. C)				
	No. 8 Gauge (0.128 in. (3.25 mm))	No. 14 Gauge (0.064 in. (1.63 mm))	No. 20 Gauge (0.032 in. (0.81 mm))	No. 24 Gauge (0.020 in. (0.51 mm))	No. 28 Gauge (0.013 in. (0.33 mm))
J	1400 (760)	1100 (590)	900 (480)	700 (370)	700 (370)
K	2300 (1260)	2000 (1090)	1800 (980)	1600 (870)	1600 (870)
T	---	700 (370)	500 (260)	400 (205)	400 (205)

NOTE: This table gives the recommended upper temperature limits for the various thermocouples and wire sizes, these limits apply to protected thermocouples, that is, thermocouples in conventional closed-end protecting tubes. They do not apply to sheathed thermocouples having compacted mineral oxide insulation. In any general recommendations of thermocouple temperature limits, it is not practicable to take into account special cases. In actual

operation, there may be instances where the temperature limits recommended can be exceeded. Likewise, there may be applications where satisfactory life will not be obtained at the recommended temperature limits. However, in general, the temperature limits listed are such as to provide satisfactory thermocouple life when the wires are operated continuously at these temperatures.

## LIMITED WARRANTY STATEMENT

Fenwal Incorporated represents that this product is free from defects in material and workmanship, and it will repair or replace any product or part thereof which proves to be defective in workmanship or material for a period of twelve (12) months from the date of purchase but not to exceed eighteen (18) months after shipment by the seller. For a full description of Fenwal's LIMITED WARRANTY, which, among other things, limits the duration of warranties of MERCHANTABILITY and FITNESS FOR A PARTICULAR PURPOSE and EXCLUDES liability for CONSEQUENTIAL DAMAGES, please read the entire LIMITED WARRANTY on the Fenwal Quotation, Acceptance of Order and/or Original Invoice which will become a part of your sales agreement. Defective units should be returned to the factory, Ashland, Massachusetts, shipment prepaid. Fenwal Incorporated will repair or replace and ship prepaid.

M.P.33 10/29/75

**FENWAL INCORPORATED**

Division of Kidde, Inc.

**KIDDE**

Ashland, Massachusetts 01721

324 E 5M 9/82 Printed in U.S.A.

SPARE PARTS FINISHED

<u>QNTY</u>	<u>DIAGRAM</u>
3	Impeller Wearing Ring
3	Fronthead Wearing Ring Case
3	Shaft Sleeve
6	Thrust Bearing
3	Radial Bearing
6 Sets	Packing

PUMP NO K3N1-060655-1 STAGES ONE SIZE-FIGURE 8-85415  
 TD 4/30/86 DRIVER DYNO-150 MTR IMPELLER TAKE5GX  
 IMPELLER DIAMETER 17.9"  
 RPM AS NOTED  
 Certified Correct By [Signature] 4/86



*Virgil John Brady*  
*5/2/86*

CERTIFIED PUMP PERFORMANCE CURVE

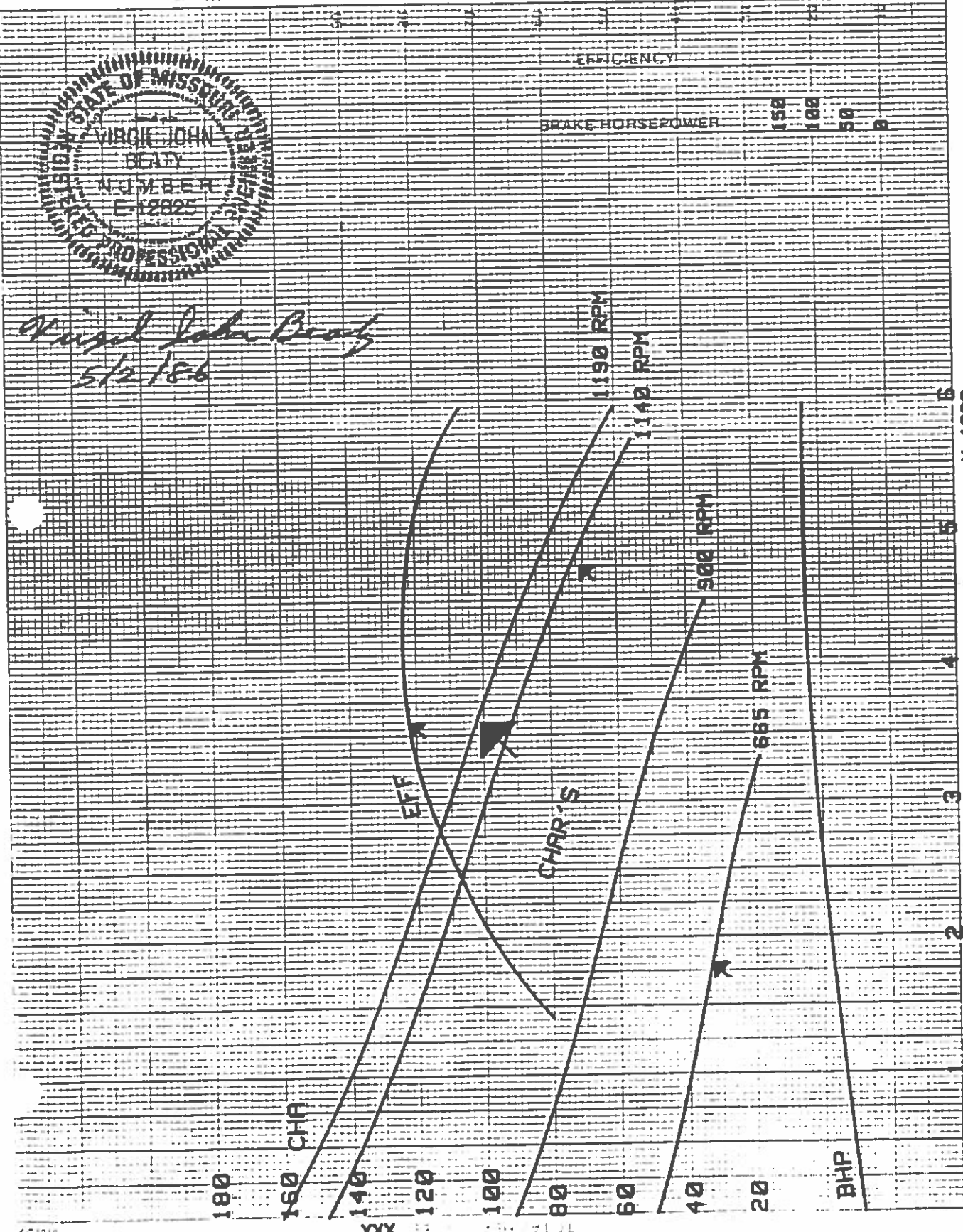

U S GALLONS PER MINUTE X 1000



INSTALLATION,  
OPERATION AND  
MAINTENANCE  
INSTRUCTIONS

# 5400

## NON-CLOG PUMPS

5410 VERTICAL

~~5420 HORIZONTAL~~

~~5440 VERTICAL CLOSE-COUPLED~~

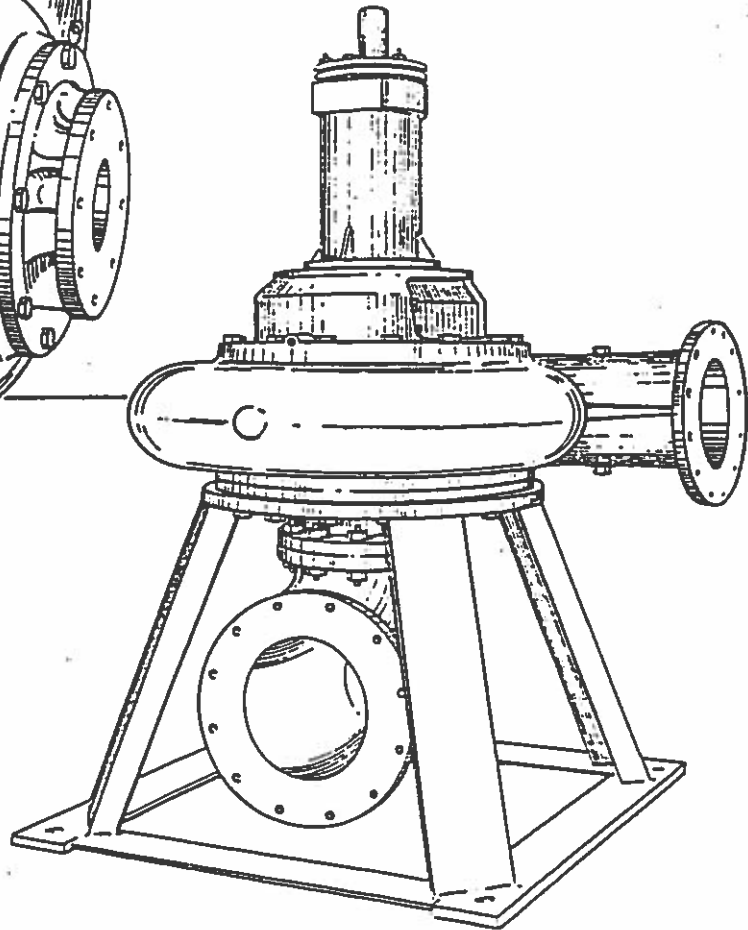
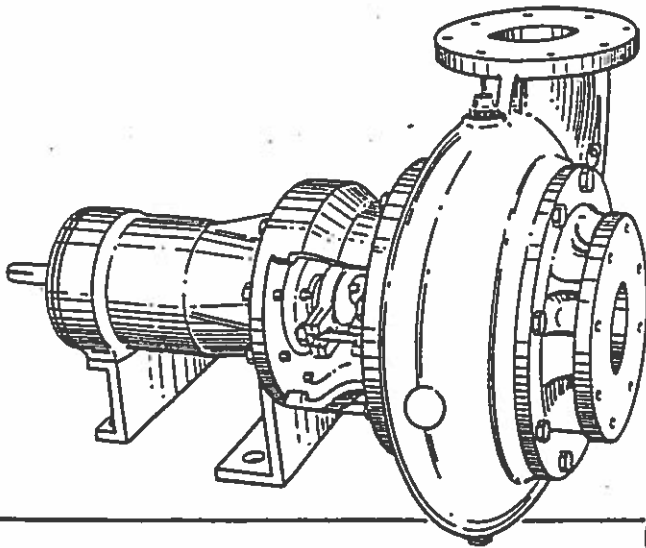

# Fairbanks Morse

# TABLE OF CONTENTS

	PAGE NUMBER
<b>WARRANTY HIGHLIGHTS</b> .....	<b>IFC</b>
<b>PUMP IDENTIFICATION</b> .....	<b>3</b>
<b>CAUTION NOTES</b> .....	<b>4</b>
<b>STORAGE OF PUMPS</b> .....	<b>4</b>
<b>WARRANTY (KC-585)</b> .....	<b>5</b>
<b>INTRODUCTION</b> .....	<b>6</b>
<b>INSTALLATION</b> .....	<b>6-10</b>
1. General .....	6
2. Net Positive Suction Head (NPSH) .....	6
3. Minimum Submergence of Suction Pipe and Pit Design .....	6
4. Location and Handling .....	7
5. Foundation .....	8
6. Leveling of the Unit .....	8
7. Grouting .....	8
8. Piping .....	8
9. Auxiliary Piping Connections and Gauges .....	8
10. Final Coupling Alignment .....	8-9
11. Dowelling .....	9
12. Flexible Shafting Alignment .....	9
13. Rotation .....	9
14. Mechanical Seals .....	10
15. Optional Filter System for Mechanical Seal .....	10
<b>OPERATION</b> .....	<b>11-12</b>
1. Operating at Reduced Capacity .....	11
2. Priming .....	11
3. Starting the Pump .....	12
4. Bearing Operating Temperature .....	12
5. Troubleshooting Operating Problems .....	12
<b>MAINTENANCE</b> .....	<b>13-21</b>
1. Maintenance History .....	13
2. Inspections and Preventative Maintenance Requirements .....	14
3. Bearing Lubrication .....	14
4. Stuffing Box .....	14-15
5. Packing Replacement .....	15
6. Wear Ring Allowable Clearance .....	15-16
7. Pump Disassembly .....	16-17
8. Pump Assembly .....	18-19
<b>REPAIR PARTS</b> .....	<b>21</b>

## **WARRANTY HIGHLIGHTS**

- 1. Seller warrants products of its own manufacture against defects in materials and workmanship under normal use and service for one (1) year from date of installation or start-up, but not more than eighteen (18) months after date of shipment.**
- 2. Accessories and components not manufactured by seller are warranted only to the extent of the original manufacturer's warranty.**
- 3. No allowances will be made for repairs or alterations effected without specific written authorization from Seller.**
- 4. Repairs or alterations made with other than OEM parts may VOID the warranty and relieve the Seller of all product responsibility.**
- 5. This warranty is VOID unless the purchaser provides protective storage, installs and maintains the equipment in accordance with manufacturer's instructions.**
- 6. Under the terms of this warranty, Seller shall not be responsible nor liable for:**
  - a. Consequential, collateral or special losses or damages.**
  - b. Equipment conditions caused by fair wear and tear, abnormal conditions of use, accident, neglect, or misuse of said equipment.**
  - c. Labor charges, loss or damage resulting from supplying of defective part(s) or improper repairs by unauthorized person(s).**
  - d. Damage caused by abrasive materials, chemicals, scale deposits, corrosion, lightning, improper voltage or mishandling.**
- 7. For complete warranty information the owner is referred to Fairbanks Morse Standard Terms and Conditions, Form KC-585, page 5.**

Congratulations! You are the owner of the finest pump commercially available. If you give it the proper care as outlined and recommended by this manual, it will provide you with reliable service and long life.

5400 NON-CLOG PUMPS

Your Fairbanks Morse 5400 is a rugged non-clog pump, available with two-port or optional bladeless impeller to allow the passage of large solids and stringy material. It is therefore ideally suited for applications such as sewage, slurry, industrial wastewater, lift stations and food processing. Standard construction is cast iron with packed shaft seal box. A variety of materials and mechanical seals are available as standard options. Additional models are available from Fairbanks Morse in self priming, biltogether and submersible pull-up designs.

This manual applies to:

- 541X Vertical pumps — using a driver independently mounted from the pump and flexible shafting.
- 542X Horizontal pumps — mounted on a common baseplate with the driver.
- 544X Vertical close-coupled pumps — using a high ring base between the pump and driver.

PUMP IDENTIFICATION

EXAMPLE:

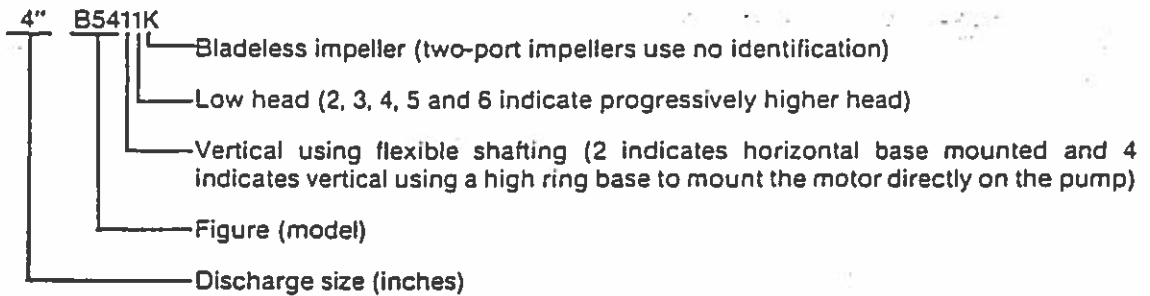

Carefully record all of the following data from your pump nameplate. It will aid in obtaining the correct replacement parts for your pump.

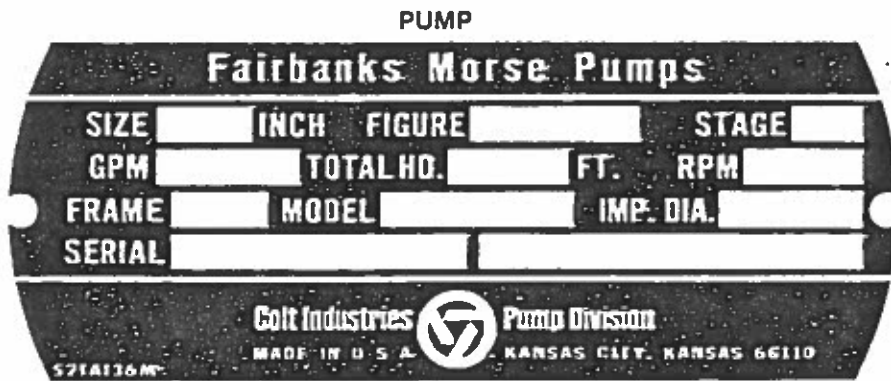

DRIVER

MANUFACTURER _____			
H.P.: _____	SERIAL NUMBER: _____		
FRAME: _____	SPEED: _____	VOLTAGE: _____	

To obtain additional data on hydraulics and pump selection and operation, we suggest you purchase both of the following reference books:

1. Fairbanks Morse "Hydraulic Handbook" available from the factory
2. Hydraulic Institute Standards

Hydraulic Institute  
1230 Keith Building  
Cleveland, Ohio 44115

## CAUTION NOTES AND STORAGE OF PUMPS

---

These instructions apply to the pump only. They are intended to be general and not specific. If your operating conditions ever change, always refer to the factory for reapplication. Always refer to the manuals provided by manufacturers of the other equipment for their separate instructions.

### CAUTION IMPORTANT SAFETY NOTICE

The installation, use and operation of this type of equipment is affected by various federal, state and local laws and the regulations concerning OSHA. Compliance with such laws relating to the proper installation and safe operation of this type of equipment is the responsibility of the equipment owner and all necessary steps should be taken by the owner to assure compliance with such laws before operating the equipment.

### STORAGE OF PUMPS

If the equipment is not to be immediately installed and operated, store it in a clean, dry, well ventilated place, free from vibrations, moisture, and rapid or wide variations in temperature.

#### SPECIAL INSTRUCTIONS:

Rotate the shaft for several revolutions at least once every two weeks to:

1. Coat the bearing with lubricant
2. Retard oxidation or corrosion and
3. Prevent possible false brinelling

**MECHANICAL SEAL PUMPS:** Pour at least 4 ounces of mineral oil into the seal housing and drain the oil just prior to start up.

#### CONSIDER A UNIT IN STORAGE WHEN:

1. It has been delivered to the jobsite and is awaiting installation.
2. It has been installed but operation is delayed pending completion of construction.
3. There are long (30 days or more) periods between operation cycles.
4. The pump is shut down for periods of longer than 30 days.

**NOTE:** Storage requirements vary depending on the length of storage, the climatic environment and the equipment. For storage periods of three months or longer, contact the manufacturer for specific instructions. Improper storage could damage the equipment which would result in non-warranty covered restoration requirements or non-warranty covered product failures.

**STANDARD WARRANTY:** Seller warrants products of its own manufacture against defects in materials and workmanship under normal use, and service for one (1) year from date of installation or startup, but not more than eighteen (18) months after date of shipment. Accessories and components not manufactured by Seller are warranted only to the extent of the original manufacturer's warranty. Notice of the alleged defect must be given to Seller in writing with all identifying details including serial number, type of equipment and date of purchase within thirty (30) days of the discovery of same during the warranty period. Seller's sole obligation on this warranty shall be, at its option, to repair or replace or refund the purchase price of any product or part thereof which proves to be defective as alleged. No allowances will be made for repairs or alterations effected without specific written authorization from Seller.

If requested by Seller, such product or part thereof must be promptly returned to the manufacturer prior to any attempted repair; or sent to an authorized service station designated by the manufacturer. All shipping expenses are to be prepaid by the Buyer. Seller accepts no responsibility for loss or damage in transit of goods, nor will any warranty claim be considered unless the returned goods are received intact and undamaged as a result of shipment. Repaired or replaced material returned to customer will be shipped F.O.B. the manufacturer's factory.

Seller warrants repaired or replaced parts of its own manufacture against defects in materials and workmanship under normal use and service for ninety (90) days or for the remainder of the warranty on the product being repaired. This warranty applies to the repaired or replaced part and is not extended to the product or any other component of the product being repaired.

Under the terms of this warranty, Seller shall not be responsible nor liable for:

- a. Consequential, collateral or special losses or damages.
- b. Equipment conditions caused by fair wear and tear, abnormal conditions of use, accident, neglect, or misuse of said equipment.
- c. Labor charges, loss or damage resulting from the supplying of defective part(s) or improper repairs by unauthorized person(s).
- d. Damage caused by abrasive materials, chemicals, scale deposits, corrosion, lightning, improper voltage or mishandling.

Seller reserves the right to substitute new equipment and/or improve the part(s) on any equipment judged defective without further liability. All repairs and/or services performed by Seller, not adjusted as covered by this warranty, will be charged in accordance with the current equipment and service prices.

This warranty is VOID unless the purchaser provides protective storage, installs and maintains the equipment in accordance with manufacturer's instructions.

Credit will NOT be allowed nor shipment accepted on any part(s) or equipment returned unless prior approval in writing has been obtained.

**THIS WARRANTY IS THE SOLE WARRANTY OF SELLER AND ANY OTHER WARRANTIES EXPRESS, IMPLIED IN LAW OR IMPLIED IN FACT, INCLUDING ANY WARRANTIES OF MERCHANTABILITY AND FITNESS FOR USE, ARE HEREBY SPECIFICALLY EXCLUDED.**

No employee of the Seller and no agent, dealer or distributor has any authority to change or enlarge the terms of this warranty to obligate the Seller to other than strictly the terms of this written warranty.

**LIABILITY LIMITATIONS:** Under no circumstances shall the Seller have any liability for liquidated damages or for collateral, consequential or special damages or for loss of profits, or for actual losses or for loss of production or progress of construction, whether resulting from delays in delivery or performance, breach of warranty, negligent manufacture or otherwise. The aggregate total liability of Seller in connection with the performance of this order, whether for breach of contract or warranty, negligence, indemnity or otherwise, shall in no event exceed the contract price. Buyer agrees to indemnify and hold harmless Seller from all claims by third parties in excess of these limitations.

Since the compliance with the various Federal, State and Local laws and regulations concerning occupational health and safety and pollution are affected by the use, installation and operation of the equipment and other matters over which the Seller has no control, the Seller assumes no responsibility for compliance with those laws and regulations, whether by way of indemnity, warranty or otherwise.

## INTRODUCTION

This manual contains information which is the result of engineering and research efforts. It is designed to supply adequate instructions for the installation, operation and maintenance of your pump. Failure or neglect to properly install, operate or maintain your pump may result in personal injury, property damage or unnecessary damage to the pump.

Variations exist in both the equipment used with these pumps and in the particular installation of the pump and driver. Therefore, specific operating instructions are not within the scope of this manual. The manual contains general rules for installation, operation and maintenance of the pump.

Observe all caution or danger tags attached to the equipment or included in this manual.

## INSTALLATION

## 1. GENERAL

**CAUTION: CAREFULLY READ ALL SECTIONS OF THIS MANUAL AND ALL OTHER INSTRUCTION MANUALS PROVIDED BY MANUFACTURERS OF OTHER EQUIPMENT SUPPLIED WITH THIS PUMP.**

Upon receipt of the shipment, unpack and inspect the pump and driver assemblies and individual parts to insure none are missing or damaged. Carefully inspect all boxes and packing material for loose parts before discarding them. Report immediately to the factory, and to the transportation company involved, any missing parts or damage incurred during shipment, and file your "damaged and/or lost in shipment" claim with the carrier immediately.

Horizontal pump and driver assemblies mounted on a structural steel base are aligned at the factory. However, alignment may be disturbed in transit or during installation. It must be checked after the unit is leveled on the foundation, after the grouting has set and the foundation bolts are tightened, and after piping is completed.

Tapped mounting blocks are furnished with horizontal pumps when the driver is to be field mounted. After the alignment of the driver is completed, the mounting blocks must be welded to the base and the alignment rechecked.

When the pump and driver are mounted on separate base structures, the pump should be leveled and aligned first, and then the driver leveled and lined up with the pump. With separate bases, a flexible shaft between pump and driver must be used.

The installation of a vertical pump is essentially the same as for the horizontal configuration. Foundation, piping and alignment adjustments are accomplished using the same basic techniques.

## 2. NET POSITIVE SUCTION HEAD (NPSH)

NPSH can be defined as the head (energy) that causes liquid to flow through the suction pipe and enter the eye of the impeller.

NPSH is expressed in two values (1) NPSH required (NPSHR) and, (2) NPSH available (NPSHA). It is essential that NPSHA always be greater than NPSHR to prevent cavitation, vibration, wear and unstable operation.

NPSHR is a function of the pump design and therefore varies with the make, size, capacity and speed of the pump. The value for your pump can be obtained from your pump performance curve or the factory.

NPSHA is a function of your system and may be calculated as follows:

A. When the source of liquid is above the pump:

$$\text{NPSHA} = \text{barometric pressure (feet)} + \text{static suction head (feet)}^* - \text{friction losses in suction piping (feet)} - \text{vapor pressure of liquid (feet)}$$

B. When the source of liquid is below the pump:

$$\text{NPSHA} = \text{barometric pressure (feet)} - \text{static suction lift (feet)}^* - \text{friction losses in suction piping (feet)} - \text{vapor pressure of liquid (feet)}$$

\* The datum elevation line for vertical pumps is the impeller nut. The datum elevation line for horizontal pumps is the impeller center line. (See the Hydraulic Institute Standards for additional information.)

## 3. MINIMUM SUBMERGENCE OF SUCTION PIPE AND PIT DESIGN

Generally, it is required that an evenly distributed flow of non-aerated water be supplied to the suction bell. Improper pit design or insufficient suction pipe submergence can result in intake vortexing which reduces the pump's performance and can result in severe damage to the pump.

We recommend that you secure the advice of a qualified Consulting Engineer for the analysis and design of the suction pit. Significant engineering data on pit design is provided in the Hydraulic Institute Standards.

Upon request, Fairbanks Morse will review plans and give general comments on the installation, but will not approve such plans for a specific installation and will accept no responsibility or liability for the performance of the pump intake structure.

#### 4. LOCATION AND HANDLING

The pump should be installed as near the fluid as possible so a short direct suction pipe can be used to keep suction losses at a minimum. If possible, locate the pump so the fluid will flow to the suction opening by gravity. The discharge piping should be direct and with as few elbows and fittings as possible. The total net positive suction head available (NPSHA), which includes the suction lift and pipe friction losses, must be equal to or greater than the net positive suction head required (NPSHR) by the pump.

The pump and driver should be located in an area that will permit periodic inspection and maintenance. Head room and access should be provided and all units should be installed in a dry location with adequate drainage.

**WARNING: DO NOT PICK UP THE COMPLETE UNIT BY THE DRIVER OR PUMP SHAFTS OR EYE BOLTS.**

~~To lift a horizontal mounted unit, a chain or suitable lifting device should be attached to each corner of the base structure.~~ Vertical mounted units may be lifted by using a sling through the motor high ring base, or by the eye bolts when provided in the pump casing. The individual driver may be lifted using the proper eye bolts provided by the manufacturer, but these should not be used to lift the assembled unit.

#### 5. FOUNDATION

The foundation should have a level surface and be of sufficient mass to prevent vibration and form a permanent rigid support for the unit. The most satisfactory foundations are concrete with anchor bolts of adequate size imbedded in the foundation in pipe sleeves with an inside diameter  $2\frac{1}{2}$  times larger than the bolt diameter. This will allow for final accurate positioning of the unit.

Recommended anchor bolt design is available from the factory.

#### 6. LEVELING OF THE UNIT

Lower the unit onto the foundation, positioning the base structure or vertical pump base so the anchor bolts are aligned in the middle of the holes in the base. On all units, horizontal or vertical, always disconnect the coupling halves and never reconnect them until all alignment operations are complete.

Set the base on metal shims or metal wedges placed directly under the part of the base carrying the greatest weight, and spaced close enough to give uniform support and stability.

Adjust the metal shims or wedges until the shaft of the pump and driver are level or vertical as appropriate and until pump and driver shaft are aligned with each other. Make sure that all shims or wedges fit firmly between the foundation and the base.

If leveling nuts are installed on the anchor bolts and are used for alignment, follow the same procedure as with shims or wedges. Support the base with additional shims or wedges if necessary. Make sure that all nuts and shims are in firm contact with the base.

Tighten the foundation bolts snugly, but not too firmly, and recheck the shafts for alignment before grouting.

**CAUTION: THE PUMP AND THE DRIVER MOUNTING SURFACES ARE PARALLEL WHEN MANUFACTURED, AND THE PUMPS AND THE DRIVERS ARE ALIGNED AT THE FACTORY BEFORE SHIPMENT. DO NOT DISTORT THE BASE BY APPLYING UNDUE FORCES DURING THE ALIGNMENT PROCESS.**

BASEPLATE INSTALLATION

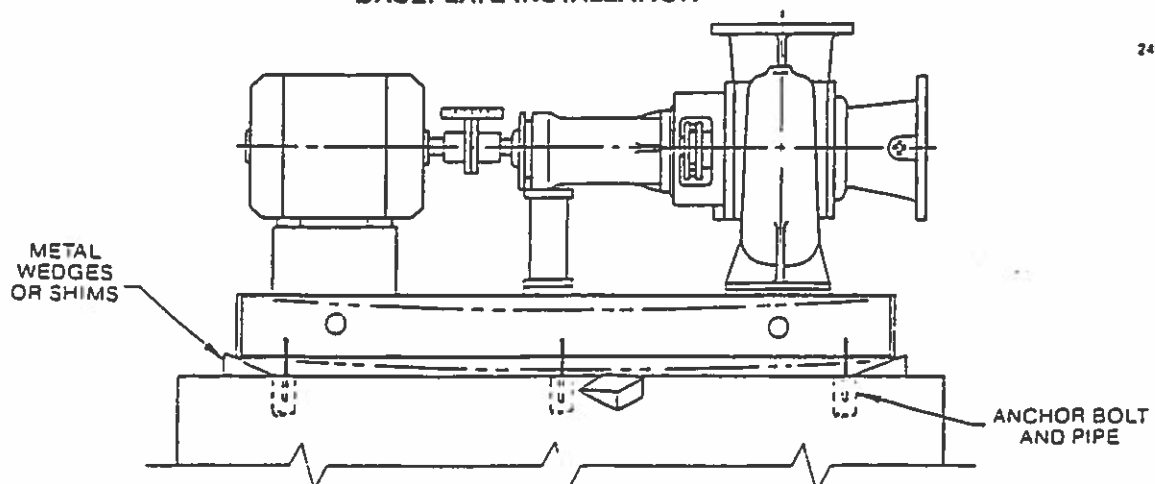



## 7. GROUTING

When the alignment is correct, the unit should be grouted using a high grade nonshrinking grout. On horizontal units the entire base should be filled with grout. Be sure to fill all gaps and voids.

Do not fill the pipe sleeves with grout.

If leveling nuts are used, make sure they are not imbedded in grout. Provide access in the grout to the leveling nuts so that they can be backed off after the grout has cured.

Allow the grout to fully cure before backing off the leveling nuts (if used) and firmly tightening the foundation bolts. Then recheck the alignment before connecting the piping.

## 8. PIPING

**CAUTION: ALL PIPING CONNECTIONS MUST BE MADE WITH THE PIPE IN A FREE SUPPORTED STATE, AND WITHOUT THE NEED TO APPLY VERTICAL OR SIDE PRESSURE TO OBTAIN ALIGNMENT OF THE PIPING WITH THE PUMP FLANGE.**

**CAUTION: AFTER ALL THE PIPING IS CONNECTED, THE PUMP AND DRIVER ALIGNMENT MUST BE RECHECKED.**

All piping should be independently supported near the pump so that pipe strain will not be transmitted to the pump casing. The suction and discharge piping should be one or two sizes larger than the pump flange sizes, especially where the piping is of considerable length. Any flexible joints installed in the piping must be equipped with tension rods to absorb piping axial thrust.

The suction pipe must be air tight and sloped upward to the pump flange to avoid air pockets which will impair satisfactory pump operation. The discharge pipe should be as direct as possible with a minimum of valves to reduce pipe friction losses.

A check valve and closing valve should be installed in the discharge line and a closing valve in the suction line. The check valve, between the pump and closing valve, protects the pump from water hammer and prevents reverse rotation in the event of power failure. The closing valves are used in priming, starting and when the pump is shut down. The pump must never be throttled by the use of a valve in the suction line.

## 9. AUXILIARY PIPING CONNECTIONS AND GAUGES

In addition to the primary piping connections, your pump may require connections to the water seal ring, mechanical seal and seal filter (see the "stuffing box" and "mechanical seal" sections of this manual), stuffing box drain, discharge and suction flange pressure gauges, or baseplate drain connections. All these lines and gauges should now be installed.

## 10. FINAL COUPLING ALIGNMENT

The alignment of the coupling must be carefully checked during the installation and as the last step before starting the pump. If realignment is required, the piping should be disconnected first. After aligning, reconnect the piping in accordance with the previous instructions and again recheck the alignment.

A flexible coupling must not be used to compensate for misalignment resulting from poor installation or temperature changes.

Fairbanks Morse pumps are supplied with several different types of commercial couplings. The following instructions apply to units supplied with a Woods coupling. If your unit has a different make coupling, a loose leaf instruction sheet will be attached to this manual and should be thoroughly studied before proceeding.

**NOTE: FOR MAXIMUM LIFE, KEEP MISALIGNMENT VALUES AS NEAR TO ZERO AS POSSIBLE.**

### TYPICAL COUPLING ALIGNMENT

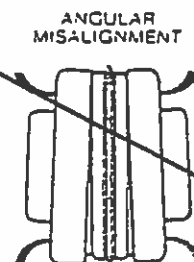
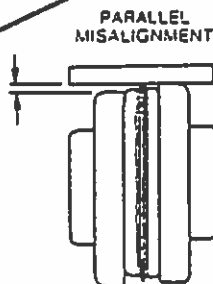
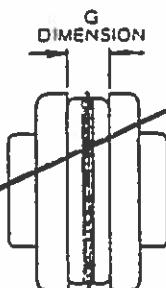

Sleeve Size	G Dimension	Types E & N		Type H*	
		Parallel	Angular	Parallel	Angular
4	3/8	.005	.021	—	—
5	3/8	.007	.028	—	—
6	7/8	.007	.035	.005	.008
7	1	.010	.040	.006	.010
8	1 1/8	.010	.047	.007	.012
9	1 1/8	.012	.054	.008	.014
10	1 1/2	.012	.064	.010	.016
11	1 5/8	.016	.075	.011	.018
12	2 1/8	.016	.087	.012	.021
13	2 3/8	.020	.092	.015	.025
14	3 1/4	.022	.121	.017	.030
16	4 3/4	.031	.165	—	—

The coupling type is printed on the sleeve.

\*Type H sleeves SHOULD NOT be used as direct replacements for EPDM or Hytrel sleeves.

**10. FINAL COUPLING ALIGNMENT (continued)**

- A. Use a blunt screwdriver to slip the wire ring out of its groove and remove the two piece sleeve.  
Check the G dimension. If it is not as listed in the preceding table, loosen one flange of the coupling and reposition it to achieve the specified G dimension.  
(NOTE: On a sleeve bearing electric motor, the armature should be at its electrical center when the G dimension is measured.)
- B. Check the parallel alignment by placing a straightedge across the two coupling flanges and measuring the maximum offset at various points around the periphery of the coupling. **DO NOT ROTATE THE COUPLING.** If the maximum offset exceeds the figure shown under "Parallel" in the preceding table, realign the coupling.
- C. Check angular alignment with a micrometer or caliper. Measure from the outside of one flange to the outside of the other at intervals around the periphery of the coupling. Determine the maximum and minimum dimensions. **DO NOT ROTATE THE COUPLING.** The difference between the maximum and minimum must not exceed the figure shown under "Angular" in the preceding table. If a correction is required, you must recheck the parallel alignment.
- D. If the coupling employs the two piece sleeve with the wire ring, force the ring into its groove in the center of the sleeve. It may be necessary to pry the ring into position with a blunt screwdriver.

**WARNING: CHECK SAFETY CODES, AND ALWAYS INSTALL PROTECTIVE GUARD OR SHIELD AS REQUIRED BY THE VARIOUS FEDERAL, STATE AND LOCAL LAWS AND THE REGULATIONS CONCERNING OSHA.**

**WARNING: COUPLING SLEEVES MAY BE THROWN FROM THE ASSEMBLY WHEN SUBJECTED TO A SEVERE SHOCK LOAD.**

**11. DOWELLING**

After the piping is connected and the final coupling alignment completed, the pump and driver should be drilled, reamed and doweled to the baseplate using a minimum of two dowels each for the pump and driver.

**12. FLEXIBLE SHAFTING ALIGNMENT**

**WARNING: THE WEIGHT OF THE INTERMEDIATE SHAFT MUST NOT BE SUPPORTED BY THE PUMP BEARINGS. IF THE WEIGHT OF THE SHAFT CANNOT BE SUPPORTED BY THE DRIVER BEARINGS, A SPECIAL THRUST BEARING SHOULD BE INSTALLED IMMEDIATELY BELOW THE DRIVER.**

For installation and alignment of the intermediate flexible shafting, refer to the manufacturer's manual.

**13. ROTATION**

Before connecting the coupling halves, bump start the driver and verify rotation is in the proper direction. The correct pump rotation is indicated by a directional on the pump casing.

**14. MECHANICAL SEALS**

**CAUTION: DRY OPERATION OF THE PUMP MAY CAUSE DAMAGE TO THE MECHANICAL SEAL AND IMPELLER.**

Double face mechanical seals having two sealing surfaces are supplied when specified. The seal manufacturer's instructions furnished with the pump must be followed.

The double mechanical seals must be lubricated and cooled by clean or filtered liquid supplied to the bottom (lowest) seal housing pipe connection. Before starting the pump, all air and oil used for storage protection must be vented out through the upper (highest) seal housing pipe connection.

**TYPICAL DOUBLE-FACED MECHANICAL SEAL**

OUTLET ON TOP

25LYA3478

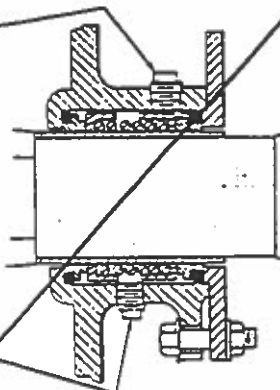

INLET ON BOTTOM

If an outside source of seal liquid is used, a pressure of 0 to 10 PSI higher than maximum pump discharge pressure must be maintained in the seal housing.

For operation of mechanical seals at higher pressures, circulation of the liquid may be required. Refer to the seal manufacturers instructions for specifics.

**15. OPTIONAL FILTER SYSTEM FOR MECHANICAL SEAL**

Some small loss of seal box fluid will occur due to vaporization of the fluid film between the seal faces, therefore, a filter capable of trapping particles larger than 25 microns is recommended for all dead-headed seals. Install the filter in the primary line between the 1/4" volute discharge tap and the seal housing connection. Either 1/4" or 3/8" tubing may be used. Under normal conditions, replace the filter element every 3-4 months. If the pumped fluid contains minerals or particles which tend to precipitate, a separate seal liquid source may be required.

**TYPICAL DEAD-HEADED FILTER SYSTEM FOR MECHANICAL SEAL**

REF. NO.	DESCRIPTION
14	SLEEVE SHAFT
30	VOLUTE
31	DISCHG
34	ADAPTER
456	MECHANICAL SEAL

AIR VENT: PURGE AIR THEN RE-INSTALL PIPE PLUG

**TYPICAL HORIZONTAL PUMP**

24LYA1934-104

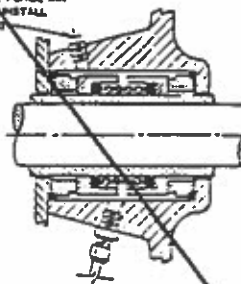

**NOTE**

1. THIS OPTIONAL FILTER SYSTEM MAY BE USED WHEN:

- A. DISCHARGE PRESSURE IS LESS THAN 80 PSI.
- B. SEAL HOUSING TEMPERATURE IS LESS THAN 160°F.

PUMP DISCHARGE FLANGE

AIR VENT: PURGE AIR THEN RE-INSTALL PIPE PLUG

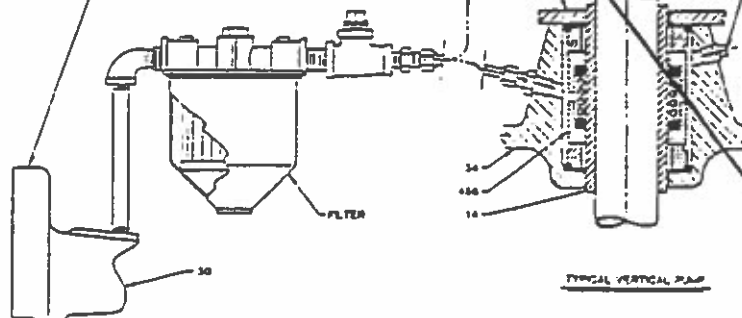

**TYPICAL VERTICAL PUMP**

Because variations may exist in both the equipment used with these pumps, and in the particular installation of the pump and driver, specific operating instructions are not within the scope of this manual. However, there are general rules and practices that apply to all pump installations and operation.

**CAUTION: BEFORE STARTING OR OPERATING THE PUMP, READ THIS ENTIRE MANUAL, ESPECIALLY THE FOLLOWING INSTRUCTIONS:**

- A. BEFORE STARTING THE PUMP, ROTATE THE UNIT OR ASSEMBLY BY HAND TO ASSURE ALL MOVING PARTS ARE FREE.
- B. BEFORE STARTING THE PUMP, INSTALL CLOSED GUARDS AROUND ALL EXPOSED ROTATING PARTS.
- C. OBSERVE ALL CAUTION OR DANGER TAGS ATTACHED TO THE EQUIPMENT.
- D. DO NOT RUN THE PUMP DRY AS THE CLOSE RUNNING FITS WITHIN THE PUMP ARE WATER LUBRICATED. RUNNING DRY MAY RESULT IN PUMP SEIZURE.
- E. BEFORE STARTING THE PUMP, FILL THE CASING AND SUCTION LINE WITH LIQUID. THE PUMP MAY BE PRIMED BY USING A PRIMING SYSTEM.
- ~~F. BEFORE STARTING A MECHANICAL SEAL PUMP, TURN ON THE SEAL WATER, VENT THE SEAL HOUSING AND CONFIRM SEAL WATER IS AT SUFFICIENT PRESSURE.~~
- G. BEFORE STARTING A PACKED BOX PUMP, ADJUST THE PACKING GLAND SO THERE IS SUFFICIENT LEAKAGE TO LUBRICATE THE PACKING AND ASSURE A COOL STUFFING BOX (SEE MAINTENANCE INSTRUCTIONS).
- H. IF EXCESSIVE VIBRATION OR NOISE OCCURS DURING OPERATION, SHUT THE PUMP DOWN AND CONSULT A FAIRBANKS MORSE REPRESENTATIVE.

#### 1. OPERATING AT REDUCED CAPACITY

In a typical application covering a wide range of flow rates, a variable speed driver is often used to adjust pump capacity, and this is taken into consideration by Fairbanks Morse when selecting the pump and impeller trim. Although these pumps are applicable over a wide range of operating conditions, care should be exercised when doing so, especially when the actual conditions differ from the sold for conditions. You should always contact your nearest Fairbanks Morse distributor or factory before operating the pumps at any condition other than that for which they were sold.

Generally, these pumps can be operated continuously at a capacity equal to 25% of the pump capacity at the best efficiency point, and at higher capacities. At capacities less than 25% of best efficiency point capacity, we recommend that the pumps be operated for intermittent periods of time only.

#### 2. PRIMING

The priming procedure is different for positive and negative suction head systems and the following procedures should be followed:

##### A. Positive suction head —

1. Open the vent on the highest point on the pump casing.
2. Open all suction valves.
3. Allow the liquid to flow from the vent hole until all air bubbles are vented, and then close the vent.
4. The pump is now primed.

##### B. Negative suction head —

1. Install an ejector or vacuum pump on the vent on the highest point on the pump casing.
2. Close the discharge valve.
3. Open the suction valve.
4. Start ejector or vacuum pump.
5. Allow the liquid to flow until a continuous flow is exhausted from the ejector, then close the valve to the vent.
6. The pump is now primed.

**3. STARTING THE PUMP**

- A. After the pump is primed, and with the discharge valve closed and the suction valve open, start the driver according to the driver manufacturer's instructions.
- B. Open the discharge valve slowly to prevent water hammer.
- C. Immediately after the pump has been started, check bearing temperature, stuffing box lubrication and operation, and pump noise level. Continue to monitor those values for the first several hours of operation.

**4. BEARING OPERATING TEMPERATURE**

These pumps are designed to operate over a wide ambient temperature range. The bearing temperature, when measured on the outside surface of the bearing housing, should not exceed 190° F. Temperatures in excess of 190° F may indicate a lack of lubricant, bearing overload or incipient bearing failure. If the temperature exceeds this limit, the pump should be stopped and the cause investigated and corrected.

**5. TROUBLESHOOTING OPERATING PROBLEMS**

If you have followed the installation and start up procedures outlined in this manual, your pump should provide reliable service and long life. However, if operating problems do occur, significant time and expense can be saved if you use the following check list to eliminate the most common causes of those problems.

**INSUFFICIENT DISCHARGE  
PRESSURE OR FLOW**

1. Pump not primed.
2. Speed too low. Check driver.
3. Discharge head too high.
4. Suction lift too high.
5. Wrong direction of rotation.
6. Air leaks into suction piping, stuffing box or gaskets.
7. Impeller passage partially plugged.
8. Impeller damaged.
9. Impeller running clearance too large.
10. Insufficient suction line submergence.
11. Air in liquid.
12. Impeller diameter too small.
13. Insufficient net positive suction head.

**LOSS OF SUCTION DURING OPERATION**

1. Suction line leaks.
2. Water seal line to packing box is plugged.
3. Suction lift too high.
4. Air or gases in liquid.
5. Air leaks into suction piping, stuffing box or gaskets.
6. Wrong direction of rotation.
7. Insufficient suction line submergence.

**EXCESSIVE POWER CONSUMPTION**

1. Speed too high.
2. Head lower than rating, pumps too much liquid.
3. Specific gravity or viscosity of liquid pumped is too high.
4. Mechanical defects:
  - Shaft bent.
  - Rotating element binds.
5. Misalignment.
6. System head lower than design.
7. Incorrect diameter impeller.

**VIBRATION OR NOISE**

1. Misalignment between driver and pump.
2. Foundation bolts loose or defect in grouting.
3. Mechanical defects:
  - Shaft bent.
  - Rotating element binds.
4. Head lower than rating, pumps too much liquid.
5. Pipe strain — improperly supported or aligned.
6. Pump running at shut-off condition.
7. Insufficient suction line submergence.
8. Air in liquid.
9. Impeller passages plugged.

**OVER-HEATING**

1. Bearings:
  - Excessive grease.
  - Shaft bent.
  - Rotating element binds.
  - Pipe strain.
  - Insufficient bearing lubrication.
  - Incorrect type grease.
2. Packing box:
  - Packing gland too tight.
  - Water seal line plugged.
  - ~~Air not vented out of mechanical seal.~~
  - ~~Flushing water not circulating for mechanical seal.~~

- Rose Mary Pumping Station  
Fairbanks Morse 1389

- 8X10 B5415  
Fairbanks Morse



## 2. INSPECTIONS AND PREVENTATIVE MAINTENANCE REQUIREMENTS

To assure satisfactory operation of the pump, daily inspections and periodic maintenance are required. We suggest that an inspection and maintenance log be kept and that the inspector immediately report any problems. A guide for preventative maintenance for normal applications is given below. Unusual applications with abnormal heat, moisture, dust, etc., may require more frequent inspections and service.

ITEM	ACTION REQUIRED	FREQUENCY (HOURS OF OPERATION)
Packing Box	Inspect for excess leakage Adjust gland and replace packing as necessary	150 Hours
<del>Mechanical Seal Filter</del>	<del>Replace or clean</del>	<del>1,000 hours</del>
Pump Alignment	Check for change in alignment	ANNUALLY
Vibration	Check for change in vibration	ANNUALLY
Bearings	Lubricate	Every 2,000 hours of operation, but at least once a year

## 3. BEARING LUBRICATION

Standard 5400 pumps are furnished with grease lubricated bearings.

Under normal operating conditions, the bearings must be lubricated every 2,000 hours of running time, but at least once a year regardless of total operating hours.

**CAUTION: ANY APPLICATION WITH ABNORMAL HEAT, MOISTURE, DUST, ETC., MAY REQUIRE A CHANGE IN THIS SCHEDULE AND YOU SHOULD REFER TO A LUBRICATION ENGINEER OR THE FACTORY FOR SPECIFIC INSTRUCTIONS.**

**CAUTION: THE GREASES RECOMMENDED IN THIS MANUAL WILL PROVIDE SATISFACTORY LUBRICATION OVER A WIDE TEMPERATURE RANGE. THERE IS, HOWEVER, A PRACTICAL LIMIT AND OPERATION OF THE PUMP SHOULD BE DISCONTINUED AND THE FACTORY CONSULTED IF THE TEMPERATURE, WHEN MEASURED ON THE OUTSIDE OF THE BEARING HOUSING, EXCEEDS 190° F.**

**RECOMMENDED GREASE: N.L.G.I. No. 2 lithium base multi-purpose with a mineral oil viscosity of 950-1250 SUS at 100° F., and 80-82 SUS at 210° F. SEE NEXT PAGE FOR RECOMMENDED SUPPLIERS.**

Proceed as follows during lubrication:

**WARNING: EXTREME CARE SHOULD BE EXERCISED AND STEPS TAKEN TO INSURE THAT THE DRIVER CANNOT BE ACCIDENTALLY STARTED. KEEP HANDS, FINGERS, CLOTHING AND ANY TOOLS AWAY FROM THE COUPLING. FAILURE TO DO SO COULD RESULT IN SERIOUS PERSONAL INJURY.**

- A. Stop the unit, remove the grease drain plug and connect a grease gun to the lubrication fittings.
- B. Start the unit and inject grease until the old grease is relieved through the drain openings.
- C. Immediately after lubrication, bearing temperatures may rise above the normal level. Continue running the unit until bearing temperatures stabilize at the normal level and grease stops seeping at the grease drain opening.
- D. Stop the unit, remove the grease gun, wipe off the relieved grease and replace the plug.
- E. Start the unit and resume normal operation.

## 4. STUFFING BOX

The stuffing boxes on Fairbanks Morse pumps are packed at the factory. All packing is subject to wear and should be given regular inspections and, if necessary, periodic adjustments. Generally, packed box pumps should be checked for excessive leakage every 150 hours of operation and the glands should be readjusted if necessary.

Adjustment is accomplished by lightly tightening the gland nuts, and then loosening them so they can be adjusted with finger pressure to allow a small flow of liquid to lubricate the packing. If the flow of liquid has increased and cannot be reduced by a slight tightening of the gland, replace the packing and/or shaft sleeve.



---

MAINTENANCE

---

Grease Recommendations:

Lithium Base Multi-Purpose (N.L.G.I. No. 2) grease is recommended for relubrication of pump bearings. Be sure the mineral oil viscosity range is 950 - 1250 SUS at 100° F and 80-82 SUS at 210° F for any grease used for relubrication.

The following tabulation shows several suppliers and their trade names for this grease:

<u>SUPPLIER</u>	<u>PRODUCT NAME</u>
Atlantic Richfield	Arco-MP No. 2
Gulf Oil Corp.	Gulfcrown No. 2
Sinclair	Litholine M-P No. 2
Texaco	#958 Marfak Multi-Purpose No. 2



**4. STUFFING BOX (continued)**

**CAUTION: DO NOT TIGHTEN THE GLAND TO STOP ALL LEAKAGE. LEAKAGE IS NECESSARY TO INSURE THE COOLING, FLUSHING AND LUBRICATION OF THE PACKING AND TO PREVENT SHAFT SLEEVE DAMAGE.**

The stuffing box may be fitted with a water seal ring. The sealing chamber should be connected to a source of clear water. If water is not available, grease lubrication is acceptable.

**5. PACKING REPLACEMENT**

Use genuine Fairbanks Morse replacement packing. The replacement procedure should be as follows:

- A. Stop the pump.
- B. Unbolt and remove the gland.
- C. Use a packing hook to remove the worn packing and water seal rings. Note the location of the water seal ring relative to the number of packing rings on each side of the water seal ring.
- D. Clean the packing box and shaft sleeve.
- E. Inspect the shaft sleeve for wear or rough finish and replace the sleeve with a genuine Fairbanks Morse sleeve if necessary.
- F. Install the new packing and the water seal ring.

**CAUTION: STAGGER THE PACKING END JOINTS 180° AND FIRMLY SEAT EACH RING OF PACKING AS YOU INSTALL IT.**

The following table gives the pertinent stuffing box, water seal ring, and packing dimensions.

	FRAME SIZE			
	T20	T30	T40	T60
Stuffing Box				
O.D. Sleeve	1 1/2	2 1/2	3	3 1/2
I.D. Box	2 1/2	3 1/2	4	4 1/2
Box Depth	2 1/2	3 1/2	3 1/2	3 1/2
Packing Size	3/4	1/2	1/2	1/2
Rings Packing Per Box	5	5	5	5
Water Seal Ring Width	3/4	3/4	1	1

- G. Reinstall the gland and tighten the gland nuts.
- H. Loosen the gland nuts so they can be adjusted with finger pressure to obtain the correct leakage for lubrication after start up.

**6. IMPELLER RUNNING CLEARANCE**

As the impeller and front head wear, the clearance increases causing internal leakage. This decreases the performance of the pump. The clearance can be adjusted to compensate for wear. If the desired clearance cannot be obtained, it may be necessary to rebuild the pump.

The clearance may be checked by removing the suction hand-hole cover and placing a feeler (thickness) gauge between the impeller and the fronthead (refer to the impeller adjustment drawing on page 16).

**6. IMPELLER RUNNING CLEARANCE (continued)**

- A. Back off the jackscrews, and tighten the capscrews at the bearing housing until the impeller just contacts the fronthead.
- B. Measure the gap between the bearing housing and the frame.
- C. Loosen the capscrews and tighten each jackscrew in a criss-cross method, 1/8 of a turn at a time, until the gap between the bearing housing and frame is increased by the amount of required impeller clearance shown below:

PUMP SIZE	CLEARANCE
<del>2" 3" 4" and 5"</del>	<del>.010" to .020"</del>
6" 8" and 10"	.020" to .030"

- D. Tighten the capscrews and recheck the clearance.

**CAUTION: THE CLEARANCE SHOULD BE RECHECKED AFTER TIGHTENING THE CAPSCREWS. IF THE GAP IS NOT AS SPECIFIED, REPEAT THIS ENTIRE PROCEDURE UNTIL THE PROPER CLEARANCE IS ACHIEVED.**

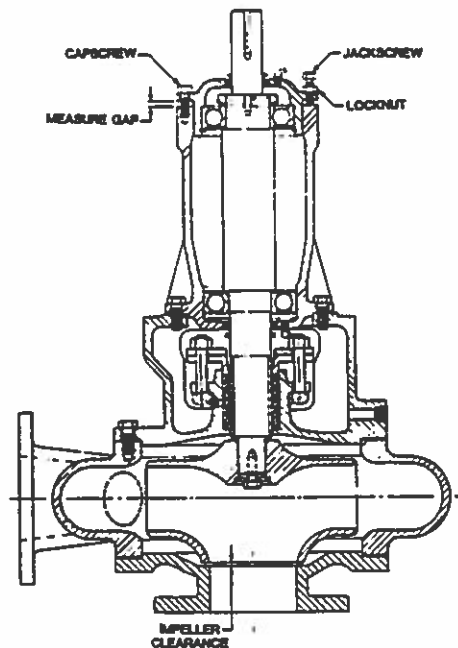

24LYA1934-107

**IMPELLER ADJUSTMENT**

- E. Tighten the locknuts to insure that the jack bolts will not get loose.

**7. PUMP DISASSEMBLY**

**CAUTION: READ THIS ENTIRE DISASSEMBLY PROCEDURE AND REFER TO THE SECTIONAL DRAWINGS IN THIS MANUAL BEFORE PROCEEDING.**

Major maintenance beyond lubrication and adjustment or replacement of the packing will require disassembly of the pump. The following are step by step instructions:

- A. Lock out the power to the driver and close the suction and discharge valves. Drain the pump, disconnect and remove the coupling or flexible shafting and the water deflector (126B). Disconnect and remove gauges and all other auxiliary piping. (Stuffing box lubrication, oil or grease lines, etc.)
- B. Remove the capscrews holding the frame adapter (34) to the volute (30).
- C. Install an eyebolt of adequate strength in the tapped (coupling) end of the shaft (4) and remove the frame and rotating assembly from the volute.

**CAUTION: THE USE OF A CRANE OR HOIST OF ADEQUATE CAPACITY IS RECOMMENDED.**

- D. Support the frame (90) and rotating assembly in a horizontal position and remove the impeller capscrew (9) and washer (9A). Because the impeller capscrew is installed with Loctite, it may be necessary to heat the capscrew to approximately 450°F to break the bond.

**WARNING: TO PREVENT POSSIBLE SERIOUS PERSONAL INJURY, HEAT RESISTANT GLOVES MUST BE WORN WHEN HANDLING HEATED PARTS.**

**7. PUMP DISASSEMBLY (continued)**

- E. Remove the impeller (1) and impeller key (102) from the shaft (4). The impeller (1) and shaft (4) have a straight bore with close tolerance fits ~~for the 5" and 6" G54X6 pumps there is a taper fit between impeller and shaft~~, and it will be necessary to use a wheel puller or similar device. In addition, because the impeller (1) is installed with Loctite or a taper fit, it will be necessary to heat the impeller hub to approximately 450° F to break the bond. Attach the puller or other equipment at the impeller vane area only — do not use the impeller shroud.

**WARNING: TO PREVENT POSSIBLE SERIOUS PERSONAL INJURY, HEAT RESISTANT GLOVES MUST BE WORN WHEN HANDLING HEATED PARTS.**

**CAUTION: CARE SHOULD BE TAKEN NOT TO DAMAGE THE IMPELLER WHEN USING A PULLER OR SIMILAR DEVICE. ATTACH THE PULLER OR OTHER EQUIPMENT AT THE IMPELLER VANE AREA ONLY, DO NOT USE THE IMPELLER SHROUD.**

- F. If your pump has wearing rings, they are secured to the impeller (1) and/or fronthead (33) with Loctite. The rings may be removed by heating them to approximately 450° F. to break the bond and then tapping them with a brass or copper mallet. If heating fails to affect removal, the rings may be ground off.

**WARNING: TO PREVENT POSSIBLE SERIOUS PERSONAL INJURY, HEAT RESISTANT GLOVES MUST BE WORN WHEN HANDLING HEATED PARTS.**

**WARNING: TO PREVENT POSSIBLE SERIOUS PERSONAL INJURY, EXTREME CARE SHOULD BE EXERCISED TO SELECT THE PROPER GRINDING EQUIPMENT, AND APPROVED SAFETY GLASSES MUST BE WORN WHEN GRINDING.**

- G. Loosen the packing box gland (19 or 31).

- H. Remove the capscrews that secure the frame adapter (34) to the frame(90) and remove the frame adapter and water deflector (126A).

- I. Remove the capscrews and jackscrews from the thrust bearing housing (139).

- J. Remove the shaft assembly from the frame using the eyebolt installed in the tapped (coupling) end of the shaft in Step 3 of these instructions.

**CAUTION: THE USE OF A CRANE OR HOIST OF ADEQUATE CAPACITY IS RECOMMENDED.**

- K. Remove the shaft sleeve (14). Because the shaft sleeve is secured with Loctite, it will be necessary to heat the shaft sleeve to approximately 450° F to break the bond.

**WARNING: TO PREVENT POSSIBLE SERIOUS PERSONAL INJURY, HEAT RESISTANT GLOVES MUST BE WORN WHEN HANDLING HEATED PARTS.**

- L. ~~T20 and T30 frame pumps use a snap ring to hold the bearing in the thrust bearing housing (139). Remove the snap ring and the thrust bearing housing.~~ T40 and T60 frame pumps use a thrust bearing housing cover (159) to hold the bearing in the thrust bearing housing (139). Remove the thrust bearing housing cover and slide the thrust bearing housing away from the bearings.

- M. Remove the bearing locknut (161), lockwasher (162). Use a bearing puller or similar device to remove the inboard (163) and outboard (168) bearings. T60 frame pumps use grease retainers (206A and 206B) between the inner and outer bearings and the bearing shaft shoulder. Remove the grease retainers.

**WARNING: TO PREVENT POSSIBLE SERIOUS INJURY, PRESSURE SHOULD BE APPLIED TO THE INNER BEARING RACE ONLY.**

**CAUTION: BECAUSE OF POSSIBLE DAMAGE OR CONTAMINATION DURING REMOVAL, BEARINGS SHOULD NOT BE REUSED AND NEW BEARINGS SHOULD ALWAYS BE INSTALLED.**

- N. Remove the split (19) or solid (31) glands, packing (212) and water seal ring (10) ~~or mechanical seal (456)~~ from the frame adapter stuffing box.

- O. ~~T20 and T30 frame pumps use an inner grease seal (140A) in the frame and an outer grease seal (159A) in the thrust bearing housing (139).~~ T40 and T60 frame pumps use an inner grease seal (140A) in the frame and an outer grease seal (159A) in the thrust bearing housing cover (159). Remove these grease seals.

**CAUTION: BECAUSE OF POSSIBLE DAMAGE DURING DISASSEMBLY, GREASE SEALS SHOULD NOT BE REUSED AND NEW GREASE SEALS SHOULD ALWAYS BE INSTALLED.**

- P. The pump disassembly is now complete. All parts should be thoroughly cleaned and inspected for wear or damage and replaced if required.

**8. PUMP ASSEMBLY**

**CAUTION: READ THIS ENTIRE DISASSEMBLY PROCEDURE AND REFER TO THE SECTIONAL DRAWINGS IN THIS MANUAL BEFORE PROCEEDING.**

The following are step by step instructions for assembly of the pump and are essentially the reverse order of the instructions for disassembly.

- A. Thoroughly clean all parts to remove all oil, grease and any foreign material and inspect for wear or damage and replace if required. Remove all parts to a clean and dust free location for assembly. Gaskets, grease seals, grease retainers and bearings should not be reused, and should be replaced with new parts.
- B. ~~T20, T30 and T40 frame pumps do not use a grease retainer. Install the inner bearing (160) on the shaft (4).~~ T60 frame pumps use a grease retainer (206A) between the inner bearing and the shaft bearing shoulder. Install the grease retainer and inboard bearings.

**WARNING: TO PREVENT POSSIBLE SERIOUS PERSONAL INJURY AND DAMAGE TO THE BEARINGS, PRESSURE SHOULD BE APPLIED TO THE INNER BEARING RACE ONLY.**

- C. ~~T20 and T30 frame pumps use a snap ring to hold the outer bearing (168) in the thrust bearing housing (139) and a grease seal (159A) in the thrust bearing housing cover.~~

~~Install the grease seal in the thrust bearing housing, slide the snap ring over the shaft and install the thrust bearing on the shaft. Install the bearing lockwasher (162) and locknut (161). Slide the thrust bearing housing over the bearing and install the snap ring in the housing.~~

T40 frame pumps use a thrust bearing housing cover (159) to hold the outer bearing (168) in the thrust bearing housing (139) and a grease seal (159A) in the thrust bearing housing cover. Install the grease seal in the thrust bearing housing cover, slide the thrust bearing housing onto the shaft, and install the bearing and thrust bearing housing cover.

- T60 frame pumps are similar to T40 frame with the addition of a grease retainer (206B) between the outer bearing (168) and the shaft bearing shoulder. Install the grease seal in the thrust bearing housing cover, slide the thrust bearing housing onto the shaft, and install the grease retainer, bearing and thrust bearing housing cover.

**WARNING: TO PREVENT POSSIBLE SERIOUS PERSONAL INJURY AND DAMAGE TO THE BEARINGS, PRESSURE SHOULD BE APPLIED TO THE INNER BEARING RACE ONLY.**

- D. Install the inner bearing grease seal (140A) and shaft/bearing assembly in the frame (90).
- E. Install the capscrews and jackscrews that hold the outer bearing assembly to the frame.

**CAUTION: DO NOT TIGHTEN THE CAPSCREWS OR JACKSCREWS. THEY WILL BE USED TO MAKE THE FINAL IMPELLER CLEARANCE ADJUSTMENT AFTER THE PUMP IS COMPLETELY ASSEMBLED.**

- F. Apply a bead of Loctite No. 609 around the impeller end of the shaft/shaft sleeve fit. Slide the shaft sleeve (14) part way onto the shaft and rotate it at least one full revolution to evenly spread the Loctite, then slide the shaft sleeve over the shaft until it butts firmly against the shaft shoulder.

**CAUTION: ALLOW THE LOCTITE TO CURE FOR TWO (2) HOURS BEFORE OPERATING THE PUMP.**

- G. Install the water deflectors (126A and 126B) on the shaft.

**8. PUMP ASSEMBLY (continued)**

H. Install the packing (212) and water seal ring (10), or the mechanical seal (456), in the frame adapter (34) stuffing box.

**CAUTION: REFER TO THE MAINTENANCE SECTION OF THIS MANUAL FOR SPECIFIC INSTALLATION INSTRUCTIONS FOR THE PACKING OR MECHANICAL SEAL.**

~~I. If your pump uses a mechanical seal, slide one (1) piece mechanical seal gland (31) over the shaft.~~

J. Apply a light coat of grease to the shaft sleeve (14) and slide the adapter (34) over the shaft, being careful not to damage the packing or mechanical seal.

K. Secure the adapter to the frame with the capscrews. Install the packing gland (19) and gland nuts.

**CAUTION: DO NOT TIGHTEN THE GLAND NUTS. REFER TO THE MAINTENANCE SECTION OF THIS MANUAL FOR SPECIFIC PACKING ADJUSTMENT INSTRUCTIONS AFTER THE PUMP ASSEMBLY IS COMPLETED.**

L. If your pump uses impeller and fronthead wearing rings (16 and 17) they are a light press fit installed with Loctite No. 609. Apply a bead of Loctite around the impeller and fronthead between the wearing ring mating surface and install the wearing rings.

**CAUTION: BE CAREFUL TO PRESS THE WEARINGS COMPLETELY IN PLACE. THEY SHOULD BE FIRMLY BUTTED AGAINST THE CORRESPONDING IMPELLER OR FRONTHEAD SHOULDER.**

B5400 WEARING RING CONSTRUCTION

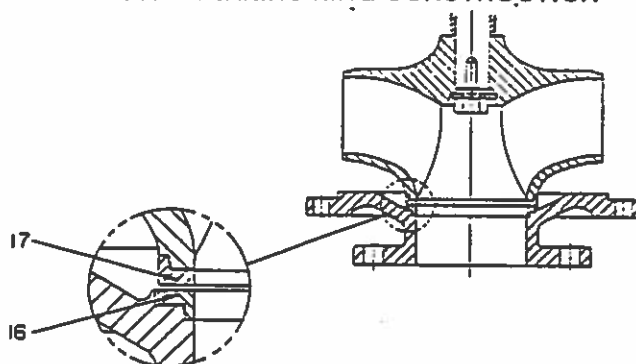

24LYA1934-53

M. All B5400 pumps (does not apply to 5" and 6" C54X6):

Prior to installing the impeller (1), impeller key (102) and impeller capscrew (9): thoroughly clean the impeller bore, the end of the shaft, and the shaft and capscrew threads to make sure that they are free from oil, dirt, and any foreign matter.

Inspect and measure the impeller bore, the shaft fit diameter, the key and the keyway for wear. Measure in several locations along the length of the fit. If wear is noticed and the clearance between the shaft and the impeller exceeds 0.003" anywhere along the length of the impeller bore, contact the factory for instructions for rework of the components.

Apply a sufficient amount of Loctite No. 609 to the shaft and to the impeller bore to cover the entire impeller fit area. Install the impeller key (102) in the shaft (4). Slide the impeller (1) in place, making sure it butts firmly against the shaft sleeve. Apply 3 or 4 drops of Loctite No. 609 to the capscrew threads, and with the impeller washer (9A) in place, install the capscrew and torque to the values shown in the following table.

~~N. 5" and 6" C54X6 pumps only:~~

~~Prior to installing the impeller (1), impeller key (102), and impeller capscrew (9): thoroughly clean the impeller bore, the end of the shaft, and the shaft and capscrew threads to make sure that they are free from oil, dirt, and any foreign matter.~~

~~Blue the impeller bore with high spot bluing compound, seat the impeller on the shaft and after removing the impeller, check the impeller to shaft taper fit. The contact area should be at least 75% of the surface. If the fit is not correct, contact the factory for rework instructions.~~

~~Apply a slight coat of oil to the impeller bore to cover the entire impeller fit area. Install the impeller key (102) in the shaft (4). Slide the impeller (1) in place, making sure it butts firmly against the shaft sleeve. Apply 3 or 4 drops of Loctite No. 609 to the capscrew threads, and with the impeller washer (9A) in place, install the capscrew and torque to the values shown in the following table.~~

## 8. PUMP ASSEMBLY (continued)

Pump Size — Figure	Pump Frame	Impeller Fastener (Capscrew Size)	Torque Foot-Pounds
2", 3" or 4" B54X1	T20	½-13	80
2", 3" or 4" B54X2	T20	½-13	80
3", 4", 5" or 6" B54X3	T30	¾-11	120
4", 5", 6" or 8" B54X4	T40	¾-11	200
<del>5" C54X5</del>	<del>T40</del>	<del>¾-9</del>	<del>200</del>
8" or 10" B54X5 or 8" B54X6	T60	¾-9	240
<del>6" C54X6</del>	<del>T60</del>	<del>1¼-7</del>	<del>240</del>

- O. Install the rotating assembly in the volute (30) using a new gasket and secure with the appropriate capscrews.
- P. Install the fronthead (33) in the volute using a new gasket and secure with the appropriate capscrews.
- Q. Refer to the maintenance section of this manual for specific instructions on impeller running clearance adjustment and adjust that clearance to the proper value.
- R. Install the gaskets, handhole covers and mechanical seal piping if the pump uses a mechanical seal.

The pump assembly is now complete except for packing adjustment, which should be accomplished after the pump is installed, primed and started up. Refer to the maintenance section of this manual for specific packing or mechanical seal adjustment instructions.

**ORDERING PARTS**

There are a variety of options available for this pump. When ordering parts, give pump serial number, size, and figure number and a complete description and item number of each part. Refer to the drawing and parts list in the back of this manual. You may order parts from your local Fairbanks Morse Distributor or directly from the factory. Consult your local telephone yellow pages for the office nearest you.

**RETURNING PARTS**

Unnecessary delays and wasted effort will be avoided if you use the proper procedure to return parts or equipment. All materials or parts returned to the factory must have prior approval and a "Returned Goods Tag."

Contact your nearest Fairbanks Morse distributor, listing the material to be returned and the reasons for the return. He will contact the factory to obtain the required approval and "Returned Goods Tag." All material to be returned should be carefully packed to avoid damage in route from rough handling or exposure to weather. The "Returned Goods Tag" will give shipping instructions. All material to be returned freight prepaid.

Fairbanks Morse makes improvements on its products from time to time and reserves the right to furnish improved parts for repairs. A part that is received and is not identical in appearance, or has a different symbol from the original part, may be interchangeable. Examine the part carefully before contacting your Fairbanks Morse representative. The parts should never be returned to the factory without first obtaining proper authorization from your Fairbanks Morse representative.

**RECOMMENDED SPARE PARTS**

FOR NORMAL DUTY	
REF. NO.	DESCRIPTION
14	Sleeve, Shaft
16	Wear Ring, Fronthead (If On Original Construction)
17	Wear Ring, Impeller (If On Original Construction)
126A	Deflector, Inner
126B	Deflector, Outer
140A	Seal, Grease
159A	Seal, Grease
163	Bearing, Inner
168	Bearing, Outer
212	Packing
	Gaskets, Complete Set

FOR SEVERE DUTY ADD THE FOLLOWING:	
REF. NO.	DESCRIPTION
1	Impeller
4	Shaft





Manual No. 001 (7/85)

CONSULT YOUR LOCAL TELEPHONE DIRECTORY  
FOR THE WARRANTY SERVICE CENTER OR DISTRICT SALES OFFICE NEAREST YOU.

---

Fairbanks, Alaska

# POTTER AND PARSONS, INC.

110 West Road, Suite 213 Towson, MD 21204  
Tel: 410-828-5544 Fax: 410-828-5727

July 12, 2018

Quotation No. 45178B

Mr. Vincent Stone  
Cape May County MUA  
Wildwood/Lower Twp. WWTF  
2701 Rt. 47 South  
Rio Grande, NJ 08242

Subject: Fairbanks Morse 8x10 Fig. B5415  
S/N K3N1-060654/K3N1-060655

Dear Mr. Stone,

We are pleased to quote the following ABBA replacement parts to fit subject pump:

Qty.	Price each
1 – Shaft sleeve, 410 S.S., #FMT60140000.	\$643.00
1 – Impeller, C.I., #FMN80010791	\$7,980.00
1 – Wear ring, impeller, 410 S.S., #FMN80170000.....	Included
1 – Fronthead, C.I., #FMN80330821	\$2,993.00
1 – Wear ring, fronthead, 410 S.S., #FMN80160000	Included
1 – Radial bearing	\$520.00
2 – Thrust bearing	\$342.00/\$684.00
1 – T60 Repair Kit	\$356.00

Includes: Impeller bolt, impeller washer, impeller key, inner and outer deflectors, inner and outer grease seals, bearing locknut and washer, outer grease retainer, packing set, water seal ring, volute gasket.

Prices include freight charges to job site.

Shipment can be made 5 to 7 weeks after receipt of order.

We hope that the above meets with your approval and that we can furnish you this excellent equipment.

Very truly yours,

Bill Ludwig  
Potter and Parsons, Inc.



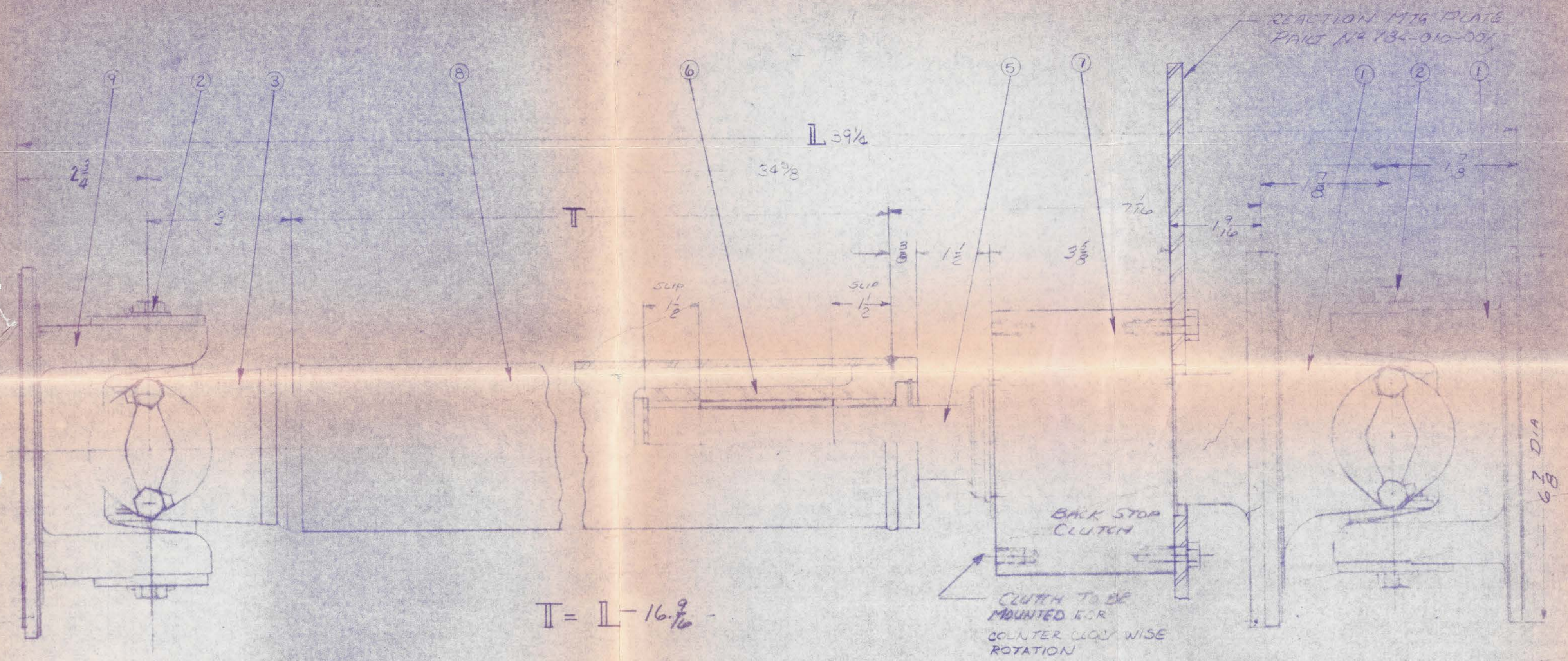

T = L - 16.9/16

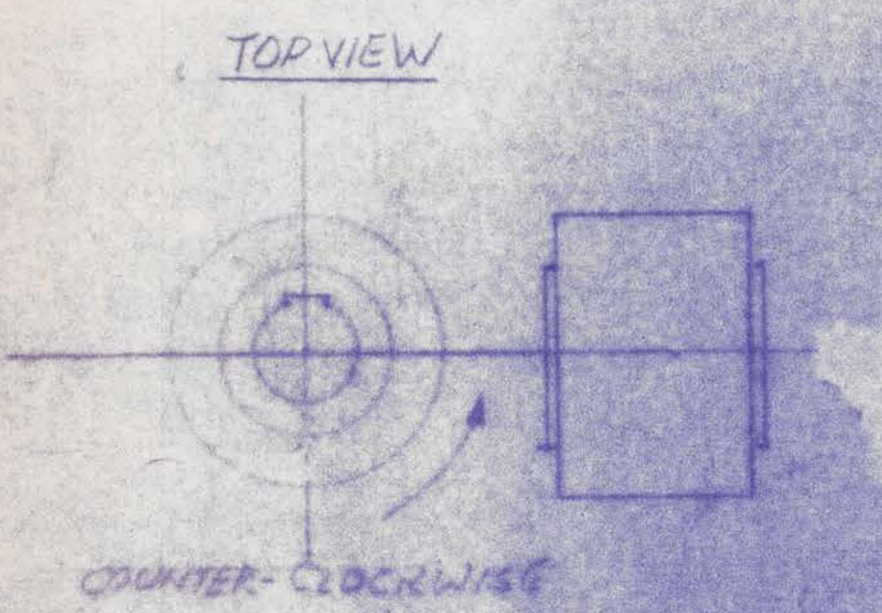

NOTE:  
LUBRICATE CLUTCH EVERY  
500 HOURS OF SERVICE WITH  
MOBILUX NO.1, RYKON NO.1 OR  
EQUIVALENT ONLY.

ITEM	PART NO.	QTY	DESCRIPTION
9	106-022-001	1	FLANGE YOKE
	199-134-002	1	CORK WASHER
	199-134-001	1	STEEL WASHER
	199-133-001	1	SNAP RING
8	3 1/2" x .134"	1	TUBE
7	145-003-002	1	CLUTCH
6	119-026-001	1	SPLINE SLEEVE
5	162-137-001	1	SLIP SHAFT FOR BACKSTOP CLUTCH
4	134-010-001	1	REACTION PLATE
3	114-027-001	1	WELD YOKE
2	130-020-001	2	CROSS & BEARING KIT
1	106-030-001	2	FLANGE YOKE

BILL OF MATERIAL

DATE		ITEM	REVISION	BY	MATERIAL SPECIFICATION	SCALE None	DWG. BY J.C.	DATE 7-23-86	Parrish Toledo, Ohio	DWG TITLE 61 VA SHAFT ASS'Y WITH BACK STOP CLUTCH
DATE		ITEM	REVISION	BY	TOLERANCES (EXCEPT DRILL AND COMMERCIAL STOCK SIZES) UNLESS NOTED	CHECKED P.S.	DATE 8-13-86	SERIES 61		DWG NO. 103413-03908

BILL OF MATERIAL (SEE NOTE)	
QTY	DESCRIPTION
1	BASE PLATE, PART NO. 158-041-002
2	UPRIGHTS 184-011-002
4	UPRIGHT ANGLE (STL), PART NO. 158-021-018
4	EXPANDED METAL, PART NO. 158-032-00 48" x 60"
1	HINGED ACCESS DOOR
20	BOLT NUT + LOCKWASHER
	SELF-TAPPING BOLT, 1/2-20 NC x 1/2"
8	3/8-16 BOLTS NUTS & LOCKWASHERS
3	1/2-13 BOLTS NUTS & LOCKWASHERS

NOTE: THIS GUARD IS SUPPLIED IN A KIT FORM AND MUST BE FITTED AND ASSEMBLED IN THE FIELD.

**INSTALLATION PROCEDURE**

1. REMOVE THE APPROPRIATE BOLTS FROM THE BEARING CAP AND BOLT BASE PLATE DIRECTLY TO BEARING CAP W/ HARDWARE SUPPLIED.
2. ATTACH THE UPRIGHT REACTION MEMBERS TO BASE PLATE W/ HARDWARE SUPPLIED. USE PREDRILLED HOLES IN BASE PLATE FOR MOUNTING.
3. ATTACH THE UPRIGHT ANGLES. NOTE: THE ANGLES HAVE 1/2" DIA. CLEARANCE HOLES ON ONE END. IF THE ANGLES ARE TO BE SHORTENED FROM THE STANDARD LENGTH SUPPLIED, BE SURE NOT TO CUT OFF THIS END.
4. USE THE 1/2" SELF-TAPPING BOLTS TO ATTACH THE ANGLES TO THE MOUNTING TABS ON THE BASE PLATE.

4. CUT THE EXPANDED METAL SECTIONS TO THE DESIRED LENGTHS AND ATTACH THEM AND THE HINGED ACCESS DOOR TO THE ANGLES USING THE 1/2" SELF-TAPPING BOLTS SUPPLIED. NOTE: THE ANGLES ARE PRE-DRILLED WITH HOLES ON 16° CENTERLINE.

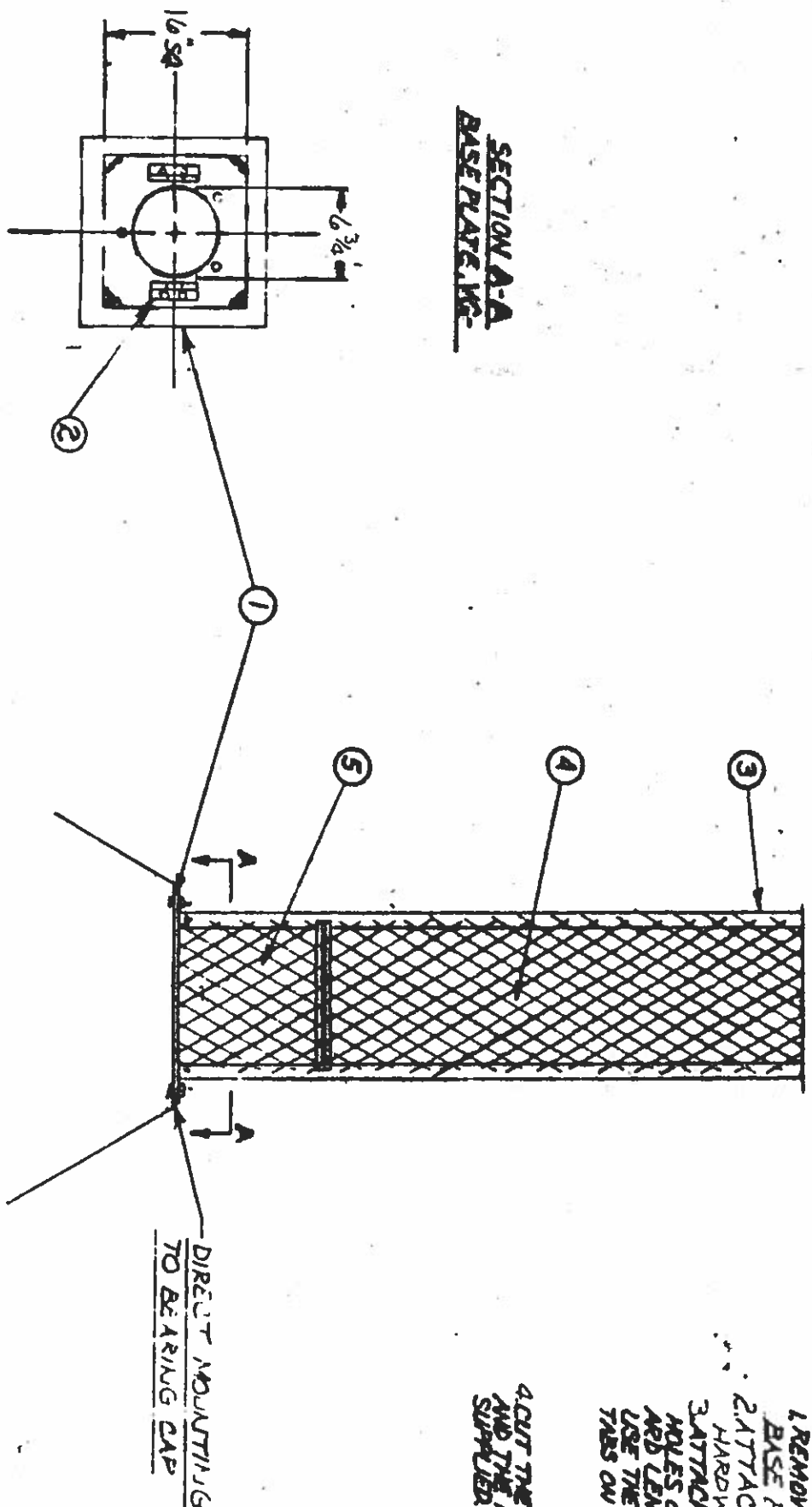

**SECTION A-A  
BASE PLATE, W.C.**

<b>MATERIAL SPECIFICATION</b> MATERIAL IS FURNISHED WITH A CORROSION RESISTANT COATING.		<b>SCALE</b> NONE		<b>Parish</b> Toledo, Ohio		<b>DWG TITLE</b> NON-REVERSING CLUTCH GUARD 48" LONG	
<b>TOLERANCES (EXCEPT DRILL AND COMMERCIAL STOCK SIZES) UNLESS NOTED</b> DEC FRACT DEG		<b>CHECKER</b> P.S. <b>DATE</b> 10-1-86		<small>This drawing is the property of Parish. It is loaned for informational purposes only and is not to be reproduced or used in any way without the express written permission of Parish.</small>		<b>DWG NO.</b> 193-009-001	

# INSTALLATION and MAINTENANCE INSTRUCTIONS

For Parrish Universal Joint/Intermediate Industrial Shafting

## RE-INSTALLATION INSPECTION

Even though drive shafts have the unique capability of accepting both axial and offset movements, the following precautions must be taken:

1. WORKING ANGLES ( $B_1$  and  $B_2$ ) of both the driver and driven equipment MUST BE EQUAL to one another within plus or minus 1 degree.

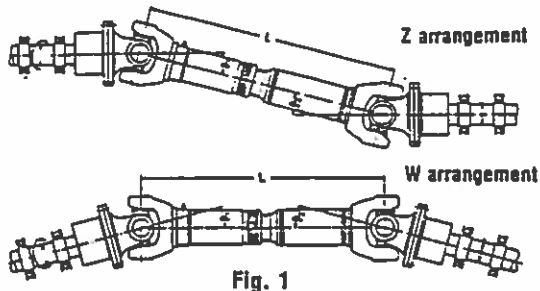

Fig. 1

An offset of  $\frac{1}{8}$  to  $\frac{1}{16}$  of an inch per foot or a working angle of 1 degree is preferred to provide needle bearing rolling action. Use Table 1 to approximate offset and/or working angle. NOTE: Working angle MUST BE HELD to within 8° on standard shafting, 5° on short coupled shafting. Where working angle exceeds these recommendations, contact Parrish Engineering.

Length in Feet	1°	2°	3°	4°	5°	6°	7°	8°
	OFFSET IN INCHES							
1	.209	.419	.625	.839	1.049	1.261	1.473	1.686
2	.418	.838	1.250	1.678	2.098	2.522	2.946	3.372
3	.627	1.257	1.875	2.517	3.147	3.783	4.419	5.058
4	.836	1.676	2.500	3.356	4.196	5.044	5.892	6.744
5	1.045	2.095	3.125	4.195	5.245	6.305	7.365	8.430
6	1.254	2.514	3.750	5.034	6.294	7.566	8.838	10.116
7	1.463	2.933	4.375	5.873	7.343	8.827	10.311	11.802
8	1.672	3.352	5.000	6.712	8.392	10.088	11.784	13.488
9	1.881	3.771	5.625	7.551	9.441	11.349	13.257	15.174
10	2.090	4.190	6.250	8.390	10.490	12.610	14.730	16.860

Table 1

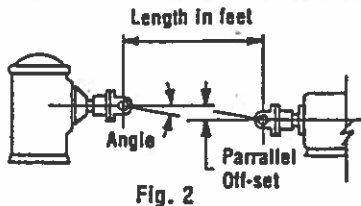

Fig. 2

2. Check flange bores and shaft diameters for PROPER FIT.

### 3. SUPPORTING STRUCTURES:

- a) FOUNDATIONS for all installations must be adequate since most power units will vibrate to some extent. Proper steel beams or concrete foundation, with hold down bolts, are necessary to maintain alignment and to eliminate damaging vibrations. IN-ADEQUATE foundations will VOID the Parrish warranty.

- b) STEADY BEARING SUPPORTS must have enough rigidity to avoid vibrations. It is recommended that the following suggestions be observed:

1. Keep SPANS as short as possible.
2. Make end CONNECTIONS rigid.
3. Use rigid beams and install so that the principle section modulus OPPOSES the horizontal forces.
4. Beam selection should be sized so that the horizontal and vertical NATURAL FREQUENCY of the beam is 4 times the maximum system RPM.

## TRANSPORTATION and STORAGE

- Drive shafts which have been stored for a long period of time, should be re-greased in working position prior to start up. See LUBRICATION section.

- Generally, drive shafts should be transported in a HORIZONTAL position. Fig. 3

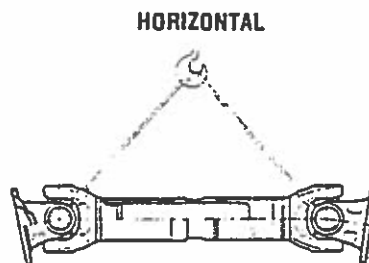

Fig. 3

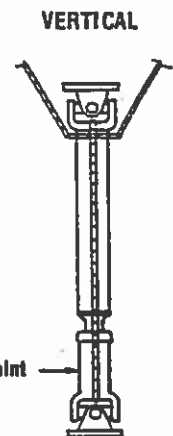

Fig. 4

- For VERTICAL INSTALLATIONS additional protection must be provided in order to eliminate the possibility of drive shaft from coming apart at the Spline connection (SLIP JOINT). Fig. 4 CAUTION: The dust cap and spline seal could be damaged by incorrectly hanging the drive shaft in a vertical position.

- SHOCKS, BUMPS, and MISHANDLING must be avoided to assure proper performance. Abuse could result in bending the drive shaft causing WHIPPING and UNBALANCE problems. Damage of this nature will VOID the warranty.

- Damage to cartons or crates during shipping becomes the responsibility of the freight carrier and consignee and must be noted or reported at time of receipt of shipment.

## COMPANION FLANGE INSTALLATION

- STOCK BORED flanges are bored with a plus .001 minus .000 tolerance and should be a slip fit over the mating shaft. Align keyways in both the flange and shaft and gently tap flange on.

- INTERFERENCE or SHRINK FITS require heating the flange uniformly (preferably submerged in oil not exceeding 350°F) to expand the bore. Align the keyways in both the shaft and flange, slide flange onto shaft and allow to cool. CAUTION: DO NOT attempt to hammer an undersize flange on without heat.

MANUFACTURED BY:

Parrish Power Products Inc.



6151 American Rd., Toledo, Ohio 43612

• Phone 419/729-1601 • Telex No. 28-6045

- **TAPER BORED** flanges require great care to insure proper interference fit between shaft and bore. GRAPH 1 shows the amount the flange has to be advanced to maintain a given interference (use dial indicator to measure advancement).

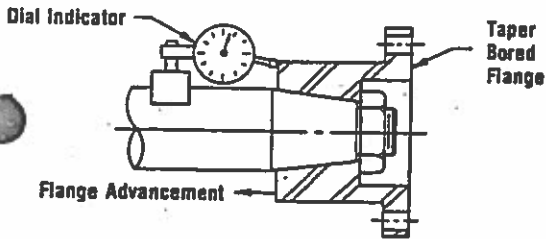
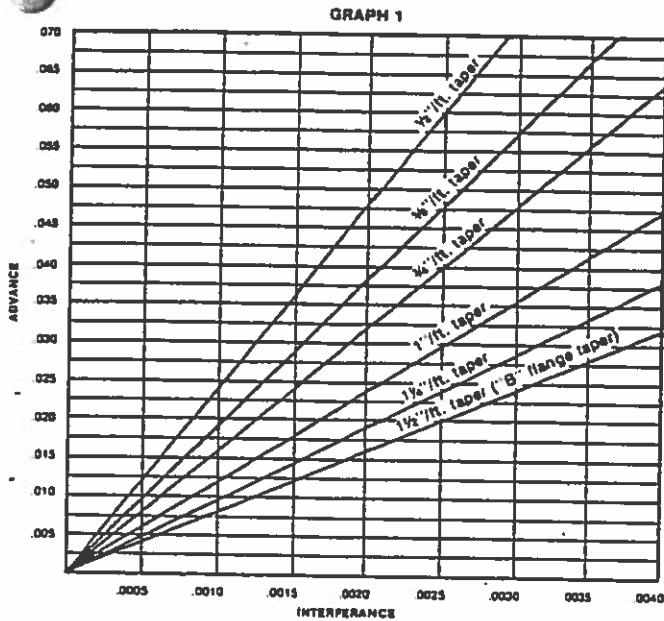

Fig. 5

**NOTE:** To facilitate installation and future removal, it is recommended that a light grease be used on shaft and threads. Install tapered flange onto shaft. Tighten retaining nut until firmly seated against flange and flange is firmly seated against shaft. Attach dial indicator (Fig. 5) to shaft and begin tightening nut until proper advancement is obtained.

**REFERENCE:** All Parrish "B" Flanges are SAE TAPERS (1½" / ft) and require an interference fit of .001 to .002 for light or medium duty shafting and .002 to .004 for heavy duty shafting.

- In **VERTICAL** applications, most of the shafting weight is supported from the upper companion flange. We **RECOMMEND** that when a drive shaft or multiple section drive shaft installation weighs over 150 lbs., it should be supported in one of the following ways:

1. Ordering flanges with an **EXTRA SET SCREW** 90° from the keyway (DO NOT use with drive shafts weighing over 300 lbs.).
2. Ordering special bored flanges with the bore machined **UNDERSIZED** for a **SHRINK FIT** (refer to above for proper installation of shrink fits).
3. Ordering flanges with a **COUNTER BORE** for a split ring adapter.
4. Ordering flanges with a **TAPER BORE** (consult with motor manufacturer).

- After installing companion flange, check runout of companion flange pilot (.003 T.I.R. maximum permissible).
- There are four types of flanges as shown in Fig. 6

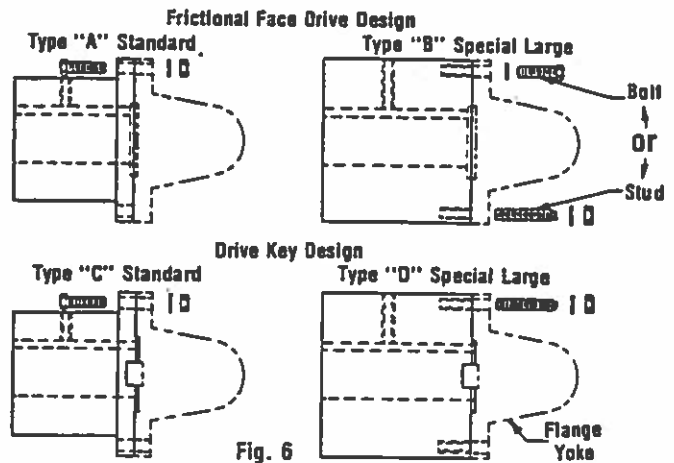

Fig. 6

Types A, C and some B utilize bolt, nut, and lockwasher which are installed after positioning drive shaft.

Type D and some B utilize a special stud, nut, and lockwasher which must be installed before positioning drive shaft. Insert **SQUARE** end of **STUD** through hole in flange yoke. Slide lockwasher over **STUD** and thread **NUT** onto **STUD** until the square portion of stud is showing.

Install drive shaft (see drive shaft installation section).

Screw **STUD** into **COMPANION.FLANGE** until firmly seated. Tighten nut to specified torque indicated in Table 2.

## INSTALLATION OF DRIVE SHAFT

- **HORIZONTAL APPLICATION** (single section).

Lower drive shaft into position and extend ends so that the pilot is seated firmly into mating companion flange and bolt holes are lined up. Insert bolts or studs, nut, and lockwashers and tighten to specified torque indicated in Table 2.

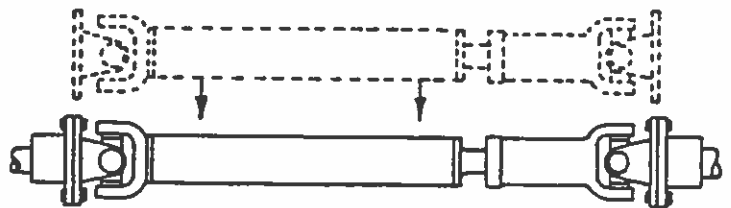

Fig. 7

- **HORIZONTAL APPLICATION** (multiple sections).

Where a single section drive shaft can not be used because of length or other restrictions, multiple drive shafts of two or more sections may be used.

In this type of installation, it is important that the **EARS** on the **YOKES** are in **LINE** after assembly as shown in Fig. 8 (also referred to as **PHASING**).

## Basic Horizontal Arrangements

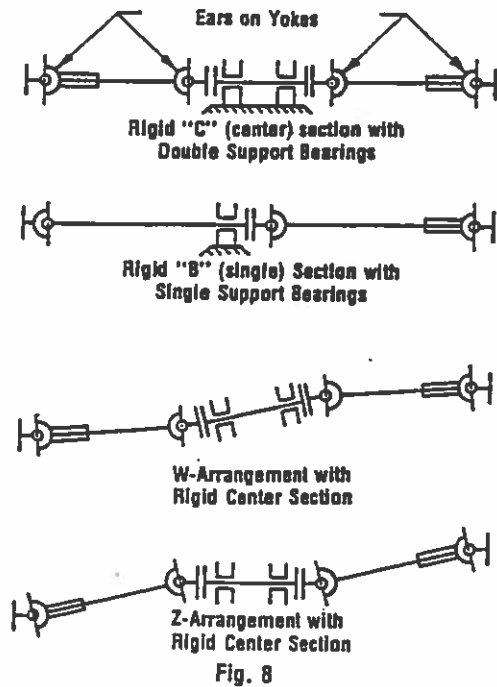

Lower drive shafts into position and extend ends so that the pilots are seated firmly into mating companion flanges and bolt holes are lined up. Insert bolts or studs, nut, and lockwashers and tighten to specified torque indicated in Table 2.

### • VERTICAL APPLICATION (single section).

Raise drive shaft into a vertical position (CAUTION: Make sure slip joint is secured to drive shaft — see TRANSPORTATION SECTION). Position drive shaft and extend ends so that pilots are seated firmly into mating companion flange and bolt holes are lined up. Insert bolts or studs, nuts, and lockwashers and tighten to specified torque indicated in Table 2.

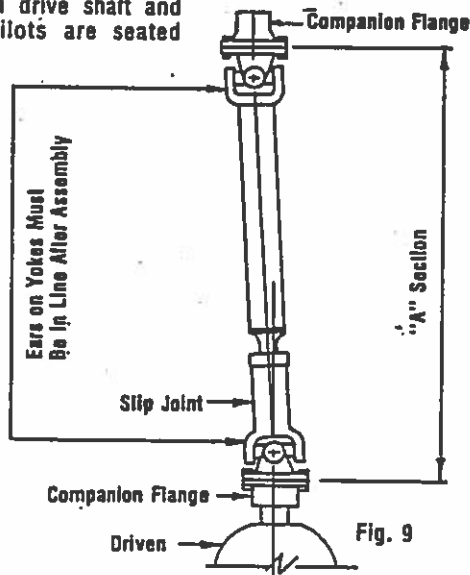

### • VERTICAL APPLICATION (multiple sections).

In multiple section installations, start with the upper most "B" section of shafting:

1. Laying the "B" section out on the floor, slide steady bearing over neck of the "B" stub followed by the TAPERED "B" FLANGE, NUT, AND COTTER PIN. NOTE: NUT must be tightened so that there is approximately .001 to .004 diametral interference between bore and shaft — refer to TAPER BORE FLANGE section on page 2.
2. Attach universal end of shafting to upper companion flange so that pilot is seated firmly and holes are lined up. Insert bolts or studs, nuts, and lockwashers and tighten to specified torque indicated in Table 2.

3. Attach STEADY BEARING to support beams and secure steady bearing to "B" stub. NOTE: Steady bearing must be self-aligning type. Steady bearings supplied by Parrish are designed for 1½ degrees misalignment. Shim if necessary.
4. Repeat Steps 1 thru 3 for each "B" Section.
5. The bottom or "A" Section is installed with the SLIP JOINT mounted to COMPANION FLANGE on the driven unit. Position drive shaft so that the pilots are seated firmly and bolt holes are lined up. Insert bolts or studs, nuts, and lockwashers and tighten to specified torque indicated in Table 2.

NOTE: Make sure that the EARS on the YOKES are in line after assembly, see Fig. 10.

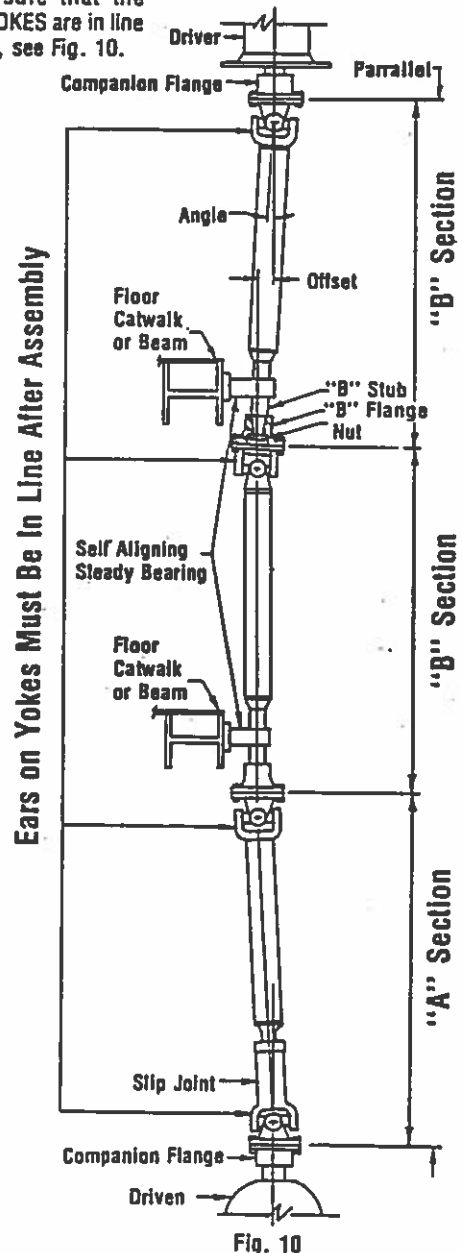

## GENERAL MAINTENANCE

- Maintenance and lubrication should be carried out at regular intervals and it is advisable to coordinate this with the maintenance work of the other machine parts.
- Lubrication cycles should be 500 hours of normal service and 200 hours of continuous service.
- Noise testing — any deviation from normal levels of noise should be located and corrected immediately.
- Check of bolts for tightness should be carried out at regular intervals.



## LUBRICATION

• Cross and bearing and sliding splines contain only enough grease to provide protection during storage. It is necessary to completely lubricate them prior to start-up to avoid premature failure.

Points of lubrication:

Cross and bearing (Point "A" - Fig. 11) and steady bearing — lubricate with a good quality lithium soap base or equivalent E.P. grease for speeds over 500 RPM or SAE 140 to 250 oil for speeds under 500 RPM. NOTE: Lubricant MUST APPEAR at all four bearing seals to assure removal of dirt and contaminants. It may be necessary to move drive shaft from side to side while applying gun pressure to allow greater clearance on the thrust end of bearing that is not purging.

- 1A. Cross and bearing lubrication for Series 200, 201, 211, 221, 231, 241, 251, 261, and 271. To lubricate, rotate drive shaft so that the oil plug is at a 45° position, Fig. 12. Remove oil plug and fill with SAE 140 GEAR OIL.

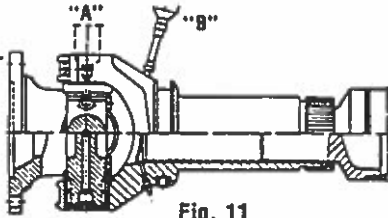

Fig. 11

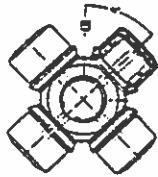

Fig. 12.

2. Sliding splines in slip joint - lubricate with only good grade of long fiber grease ("B" Fig. 11).

• Greases having acceptable properties: Cross and bearing: Shell Alvania EP2, Molyvis ST-200 grease, or Texaco PASR #629 oil or equal. Sliding splines: Texaco Marfac "O" EP or equal.

## BOLT SPECIFICATIONS

Bolt Size	Series Used In	Wrench Torque Grade
3/4 - 24	27, 31, 61, 71	31' # 5
1/2 - 20	37, 41, 81	49' # 5
1/2 - 20	48, 55	76' # 5
3/8 - 18	88, 91	213' # 8
3/4 - 16	95	375' # 8

## METRIC BOLT SPECIFICATIONS

Metric Size	Inch	Series Used In	Wrench Torque Grade
12mm x 1.75	.472 x 14.5	92, 93	83' # 8
14mm x 2	.551 x 12.7	87, 94, 96	132' # 8
16mm x 2	.630 x 12.7	97, 98, 101, 200	205' # 8
18mm x 2.5	.709 x 10.2	99, 101S, 115, 201	283' # 8
20mm x 2.5	.787 x 10.2	115S, 125, 211	401' # 8
22mm x 2.5	.866 x 10.2	125S, 135, 135S, 145, 221, 231	545' # 8
24mm x 3	.945 x 8.5	145S, 155, 241	693' # 8
27mm x 3	1.063 x 8.5	155S, 165, 251	1013' # 8
30mm x 3.5	1.181 x 7.2	261, 271	1376' # 8
36mm x 4	1.417 x 6.2	308, 408	2465' # 8
48mm x 3	1.890 x 8.5	318	6300' # 8
56mm x 4	2.205 x 6.2	428	9800' # 8
64mm x 4	2.520 x 6.4	338, 358	14,325' # 8
72mm x 4	2.835 x 6.4	348, 368	21,275' # 8

Table 2

NOTE: Bolts must be tightened in a crisscross pattern and tightened to specified torque to insure proper mating face contact.

## TROUBLE SHOOTING GUIDE

PROBLEM	CAUSE	SOLUTION
VIBRATIONS	1. Operating in or near the critical or half-critical speed. Refer to critical speed graphs.	Reduce speed or rework using special tubing.
	2. Operating in or near the driver or driven equipment natural frequency.	Consult with equipment manufacturer.
	3. Inadequate foundations, floors, or steady bearing beams. Refer to supporting structure section.	Reinforce structure.
	4. Driver or driven components out of balance.	Consult with equipment manufacturer.
	5. Variable frequency controller inducing torsional surges into system.	Consult with equipment manufacturer.
	6. Pump Cavitating.	Consult with equipment manufacturer.
	7. Ears on yoke are not in line with each other. Refer to drive shaft installation section.	Disassemble and align yokes.
	8. Drive shaft may be out of balance due to shafting being bent during shipment or balancing not specified.	Return for straightening and balancing.
	9. Cross and bearing, steady bearing, or spline wore out.	Replace defective components.
	10. U-joints are stiff due to damaged bearing.	Replace bearing.
	11. Pilots not seated at companion flange or "B" shaft connections.	Reseat flanges.
	12. If operating in conjunction with a reciprocating engine, a torsional problem may exist.	A torsional analysis should be performed.
	13. Steady bearings are not self-aligning and are binding.	Replace.
	14. Thrust bearings binding up in either the driver or driven equipment.	Replace bearings.
	15. Exceeding recommended angular misalignments.	Reduce angle.
	16. Input and output shafts are not parallel.	Shim if necessary.
	17. Runout on driver or driven shafts.	Consult with equipment manufacturer.
FLANGES SLIPPING OFF SHAFT	1. Exceeding weight limitations for stock bored flanges. 2. Set screw not tightened.	Add additional set screw. Tighten set screw.
PREMATURE FAILURE OF BEARING	1. Lack of proper maintenance.	See lubrication recommendations.
	2. Exceeding recommended angular misalignment or Max. RPM.	Reduce either or both.
	3. Excessive vibrations (See vibrations sec. above).	See above.
	4. Shafting under specified.	Refer to catalog.



CERTIFICATION DATA

CUSTOMER Fairbanks Morse Pump

CUSTOMER ORDER NO. P-261460

M.E. ORDER NO. 3274733

MODEL NO. 508UTDS212AN

TYPE TDS	FRAME 508P	HP 150/54	RPM 1200/720
HZ 60	PH 3	VOLTS 480	CL. OF INSUL. B
DUTY Cont.	AMB 40°C	ENCL DP	BRG Ball

SUPPLEMENTAL INFORMATION: Outline Drawing A-SS511484-2800

Ground Lug in Conduit Box  
Thermocouples in both bearings

*Bruce Aho*

CERTIFIED BY Bruce Aho

DATE February 28, 1986

A-5551484

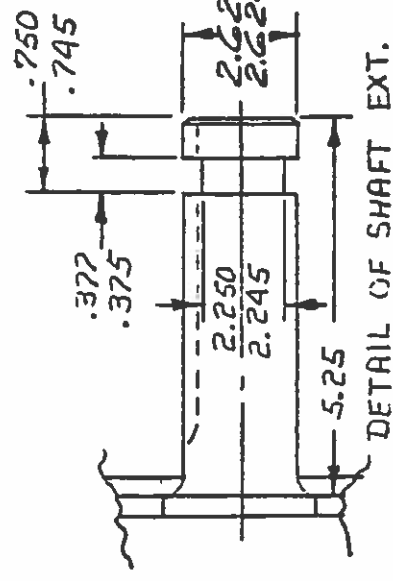
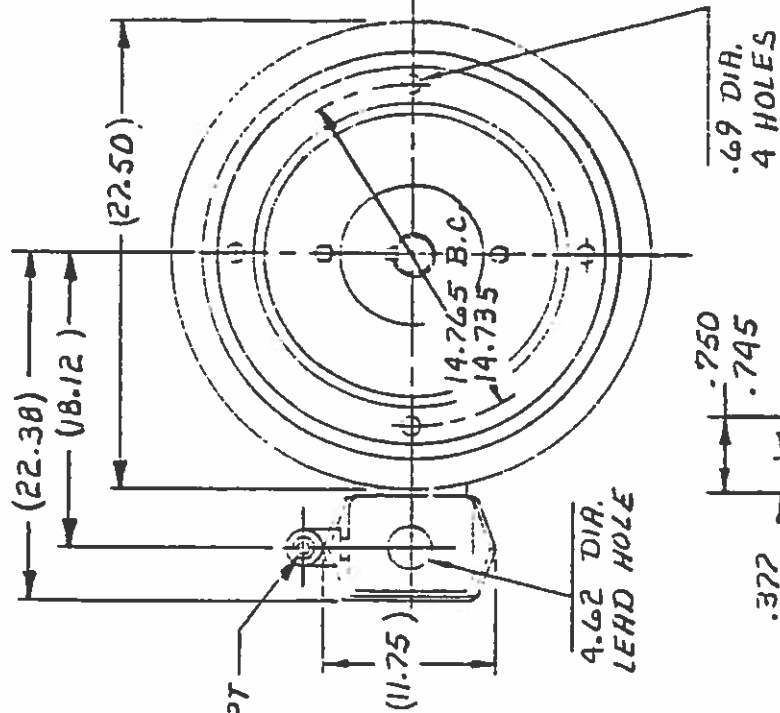
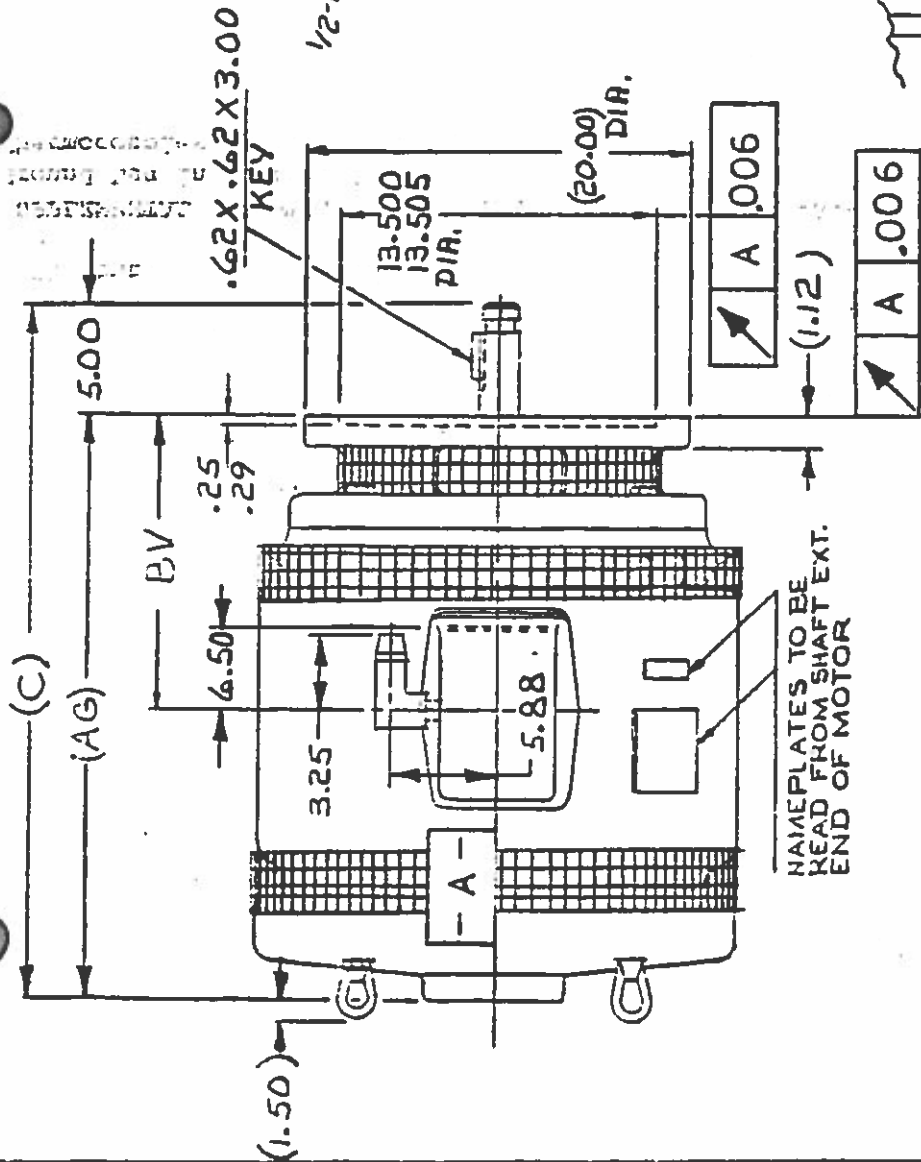

NOTE: CONDUIT BOX CAN BE ROTATED IN 90° STEPS.

DASH	FR.	C	AG	BV
2100	505P	38.75	33.75	16.50
2800	508P	45.75	40.75	20.00

UNLESS OTHERWISE SPECIFIED DIMENSIONS ARE IN INCHES

MATERIAL: STEEL

FINISH: POLISHED

DATE: 7-17-51

BY: JL

APPROVED: JL

DESIGNED BY: JL

DRAWN BY: JL

MAHARATHON ELECTRIC

GEOMETRIC DRAWING SYMBOLS: HATCH, DIMENSION, SURFACE, TOLERANCE, etc.

PART NAME: CONDUIT BOX - 500 P FR. - BB-75 - DR. PR.

DATE: 7-17-51

SCALE: 1:1

FILE: A-5551484

Colt Industries



CERTIFIED MOTOR PERFORMANCE DATA

Fairbanks Morse  
Pump Division  
3601 Fairbanks Avenue  
Kansas City, Kansas 66110  
913/371-5000

MOTOR MANUFACTURER MARATHON ELECTRIC DATE 2-27-86  
F.M. PURCHASE ORDER# P-261460 F.M. TAG# 060655

PERFORMANCE DATA BASED ON STANDARD RULES OF  IEEE  ASA  NEMA

HP	NO LOAD SPEED RPM	FULL LOAD SPEED RPM	FRAME NBR.	TYPE	ENCLOSURE
150/54	1200/720	1190/715	508P	TDS	DP

PHASE/HERTZ	VOLTS	CURRENT - AMPERES		INSULATION CLASS	MAX TEMPRISE x RESIST. — THERM.	SERVICE FACTOR
		FULL LOAD	LOCKED ROTOR			
3/60	480	172/86	1100/600	B	90	1.15

EFFICIENCY DIRECTLY MEASURED			POWER FACTOR			TORQUE AT FULL VOLTAGE			NEMA KVA/HP CODE
FULL LOAD	3/4 LOAD	1/2 LOAD	FULL LOAD	3/4 LOAD	1/2 LOAD	FULL LOAD TORQUE AT FULL LOAD SPD (LB. FT.)	LOCKED STARTING	PULL-OUT BREAKDOWN	
94.1/ 91.7	94.1/ 90.5	93.0/ 88.0	85.0/ 60.0	80.0/ 50.0	70.0/ 36.0	661/397	115/110	270/300	G

VSS  VHS  NRR  SRC

SPACE HEATERS  WATTS: \_\_\_\_\_ VOLTAGE: \_\_\_\_\_

THERMOSTATS TYPE N/A N.O.  N.C.

BEARINGS: D.E. 316 O.E. 318 MOTOR# 508UTDS212AN

MOTOR NATURAL FREQUENCY DATA: (WHERE REQUIRED)

WEIGHT: N/A

DISTANCE FROM BASE OF DRIVER TO CENTER OF GRAVITY OF DRIVER N/A

STATIC DEFLECTION OR REED FREQUENCY AT CENTER OF GRAVITY N/A

CERTIFIED BY: Earl Babbitts DATE: 2-27-86

A-EE7317

3Ø, SINGLE VOLT, 6 LEAD, 2 SPEED, 2 WINDING

K3N1-066655  
 ROSS-ARACO CORP. PO 2191  
 CAPE MAY COUNTY, NJ  
 MUNICIPAL UTIL. AUTHORITY  
 CONTRACT MN/L-PS-1  
 SEC. 15B, PG. 15B-20,  
 ARTICLE 2.10 D  
 ROSEMARY ROAD PUMPING STATION

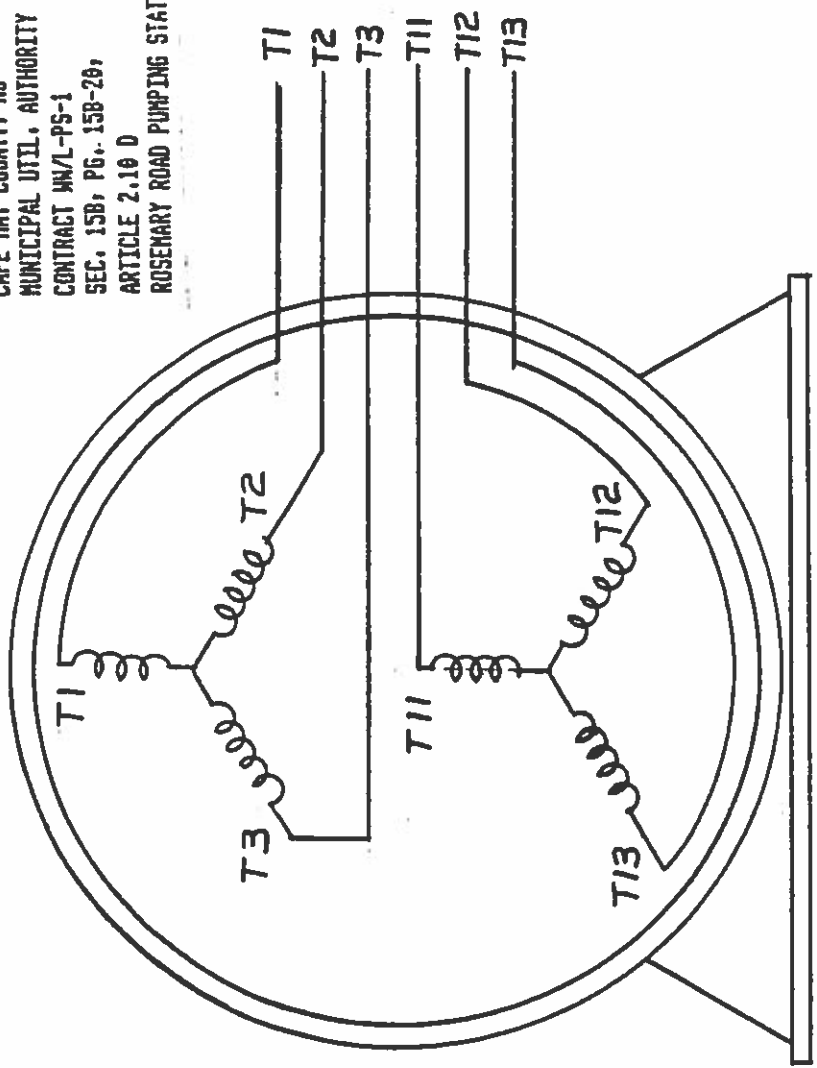
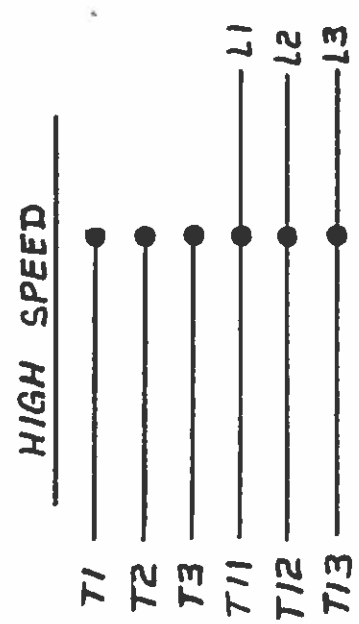
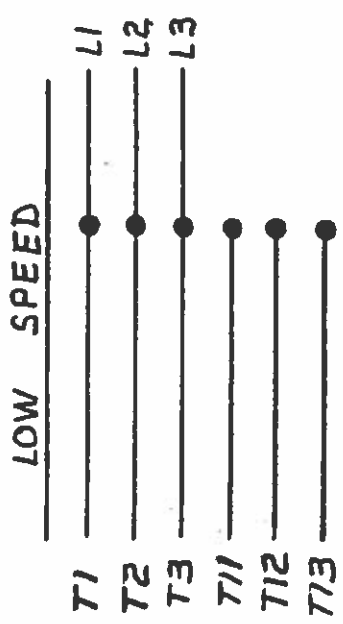

VIEW OF TERMINAL END

REV	DATE	CHANGE	NAME
9	11/19/81	UPDATED PER BILL H. REDRAWN AND UPDATED	R.R.
8	11/19/81		
PART NAME <b>3Ø SINGLE VOLTAGE - 2 SPEED CONNECTION DIAGRAM</b>			
MARATHON ELECTRIC WALUGAL, WEST CONNETT 54-0101			
UNLESS OTHERWISE SPECIFIED, DIMENSIONS ARE IN INCHES TOL ON .XXX .005 .XXX .005 .XXX .005			
GEOMETRIC DRAWING SYMBOLS: FINISH: FLAT, ROUNDT, FAULT POSITION, PARALLEL, MAXIMUM MATERIAL CONDITION (MIN), MINIMUM MATERIAL CONDITION (MAX), HOLE DIA, RADIUS, CHAMFER, CYLINDRICAL, ANGLES, SURFACE ROUGHNESS UNLESS OTHERWISE NOTED.			
DRAWN BY: <b>PH</b> 11-6-81 CHECKED BY: <b>PH</b> 11-9-81 APP'D BY: <b>PH</b> 11-9-81			
SURFACE ROUGHNESS UNLESS OTHERWISE NOTED: <input checked="" type="checkbox"/>			
ANGLE:			
DWG. NO: <b>A-EE7317</b>			



# Standard Induction Motors

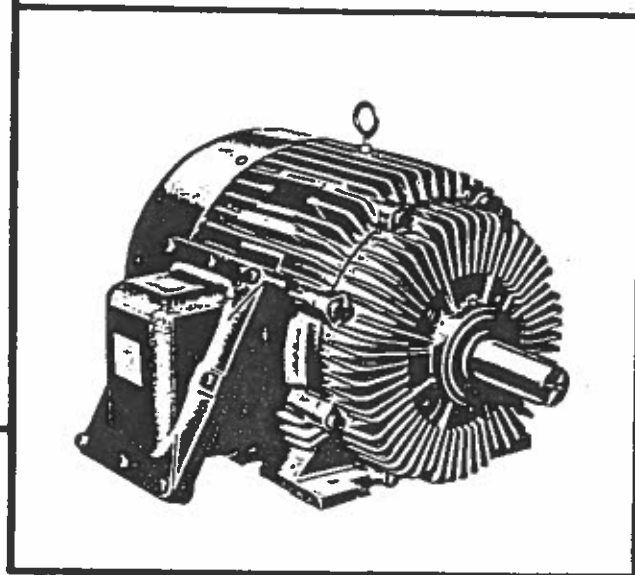
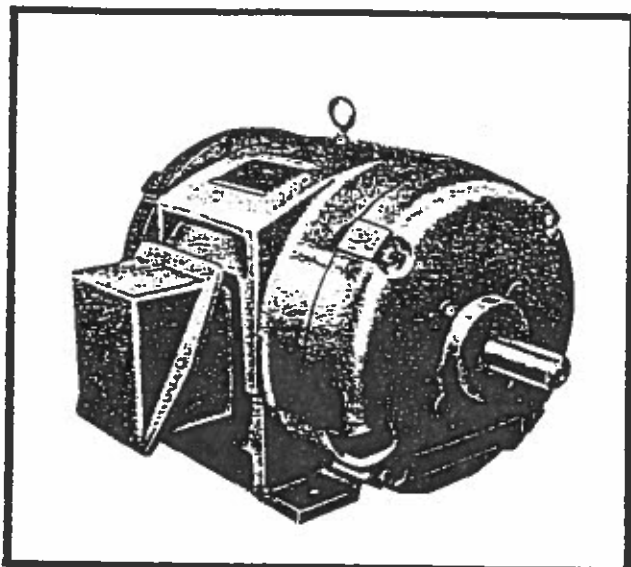

## Installation, Operation, & Maintenance Instructions

TYPICAL CUTAWAY VIEW  
 OF A MARATHON DESIGNED, DRIPPROOF, HORIZONTAL  
 INTEGRAL HORSEPOWER MOTOR & PARTS DESCRIPTION  
 364 THRU 445 FRAME SIZE

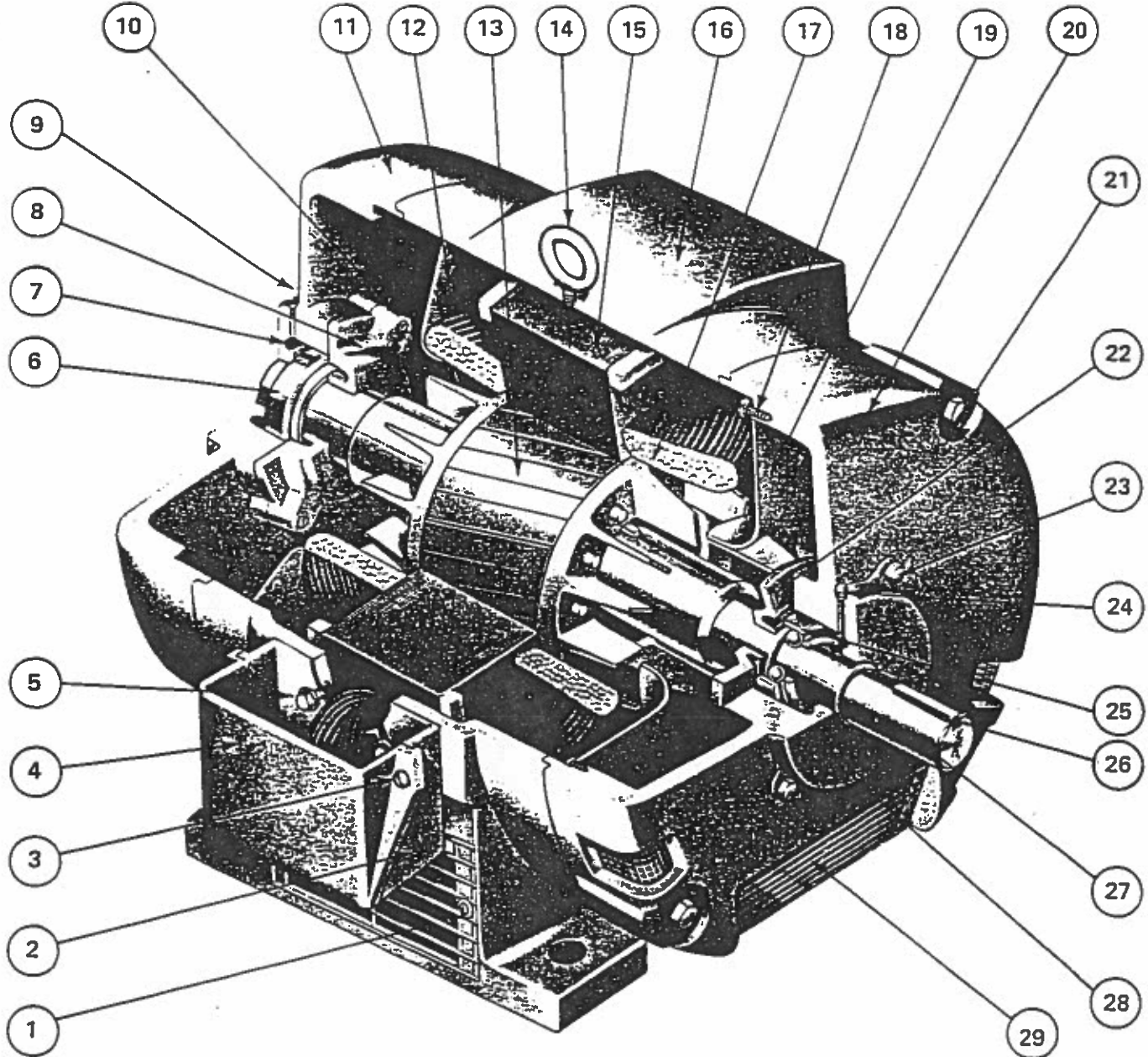

ITEM	DESCRIPTION	ITEM	DESCRIPTION	ITEM	DESCRIPTION
1.	** Frame Vent Screen	11.	Bracket O.P.E.	21.	Bracket Holding Bolt
2.	Conduit Box Bottom	12.	Baffle Plate O.P.E.	22.	Inner Bearing Cap P.E.
3.	Conduit Box Top Holding Screw	13.	Rotor Core	23.	Inner Bearing Cap Bolt
4.	Conduit Box Top	14.	Lifting Eye Bolt	24.	Grease Plug
5.	Conduit Box Bottom Holding Bolt	15.	Stator Core	25.	*Ball Bearing P.E.
6.	*Ball Bearing O.P.E.	16.	Frame	26.	Shaft Extension Key
7.	Pre-loading Spring	17.	Stator Winding	27.	Shaft
8.	Inner Bearing Cap O.P.E.	18.	Baffle Plate Holding Screw	28.	Drain Plug (grease)
9.	Grease Plug	19.	Baffle Plate P.E.	29.	** Bracket Screen
10.	Inner Bearing Cap Bolt	20.	Bracket P.E.		

P.E. = Pulley End

O.P.E. = Opposite Pulley End

\* = Bearing Numbers are shown on motor nameplate when requesting information or parts always give complete motor description, model and serial numbers.

\*\* = Bracket and frame screens are optional.

### WARNING

These instructions must be followed to ensure safe and proper installation, operation and maintenance of the motor. They should be brought to the attention of all persons who install, operate or maintain this equipment.

## GENERAL INFORMATION

Marathon Electric motors are all fully factory tested and inspected before shipment. Frequently the most likely cause of troubles may occur in either (1) shipment, (2) improperly matched power supply, or (3) failure to follow the installation precautions. These instructions are intended as a guide to eliminate these causes before they are overlooked.

### ACCEPTANCE

Check carefully for any damage that may have occurred in transit. If any damage or shortage is discovered, do not accept until an appropriate notation on the freight bill is made. Any damage discovered after receipt of equipment should be immediately reported to the carrier.

### WARNING

Failure to follow instructions and safe electrical procedures could result in serious injury or fatality. Disconnect all power before servicing. Install and ground per local and national codes. Consult qualified personnel with any questions or services required.

## INSTALLATION

### UNCRATING

After uncrating, check further that no apparent damage has been incurred in handling. See that the motor shaft and armature turn freely.

### EXPOSURE

Check to determine that the motor has not been exposed to dirt, grit, or excessive moisture in either shipment (without protection) or storage before installation. Motors in storage should have shafts turned over once each month to redistribute grease in bearings.

Never start a motor which has been wet without having it thoroughly dried.

The measure of insulation resistance (see operation) is a good dampness test. Clean the motor of any dirt or grit.

### SAFETY

Eyebolts or lifting lugs are intended only for lifting the motor and factory motor-mounted standard accessories. These lifting provisions should never be used when lifting or handling the motor and other equipment (i.e.) pumps, gear boxes, fans (or other driven equipment) as a single unit.

Eyebolt lifting capacity rating is based on a lifting alignment coincident with the eyebolt centerline. Eyebolt capacity reduces as deviation from this alignment increases.

Motors should be installed, protected and fused in accordance with latest issue of National Electrical Code, NEMA Standard Publication No. MG 2 and local requirements.

Frames and accessories of motors should be grounded in accordance with National Electrical Code (NEC) Article 430. For general information on grounding refer to NEC Article 250.

Rotating parts such as pulleys, couplings, external fans,

unusual shaft extensions should be permanently guarded against accidental contact with clothing or body extremities.

### WARNING

Disconnect power before working on motor driven equipment. Motors with automatic thermal protectors will automatically restart when the protector cools. Do not use motors with automatic thermal protectors in applications where automatic restart will be hazardous to personnel or equipment.

### WARNING

Motors with manual thermal protectors may start unexpectedly after protector trips. If manual protector trips, disconnect motor from power line. After protector cools (five minutes or more) it can be reset and power may be applied to motor.

## THERMAL PROTECTOR INFORMATION

A space on nameplate will be stamped or not be stamped to indicate:

1. Motor is thermally protected
2. Motor is not thermally protected
3. Motor is with overheat protective device

For examples, refer to paragraphs below:

1. Motors equipped with built-in thermal protection have "THERMALLY PROTECTED" stamped on the nameplate. Thermal protectors open the motor circuit electrically when the motor overheats or is overloaded. The protector cannot be reset until the motor cools. If the protector is automatic, it will reset itself. If the protector is manual, press the red button to reset.
2. Motors without thermal protection have nothing stamped on nameplate about thermal protection.
3. Motors that are provided with overheat protective device that does not open the motor circuit directly, nameplate will be stamped "WITH OVERHEAT PROTECTIVE DEVICE".
  - A. Motors with this type of "Overheat Protective Device" have protector leads brought out in the motor conduit box marked "P1" and "P2". These leads are intended for connection in series with the stop button of a 3-wire pilot circuit of a magnetic controller connected to a motor, as in Figure 1.
  - B. The load controlled by the above "Overheat Protective Device" cannot exceed the values shown in the chart below.

AC VOLTS	VOLT-AMP RATINGS	AC VOLTS	VOLT-AMP RATINGS
120	360	208	360
240	360	480	360
600	360		

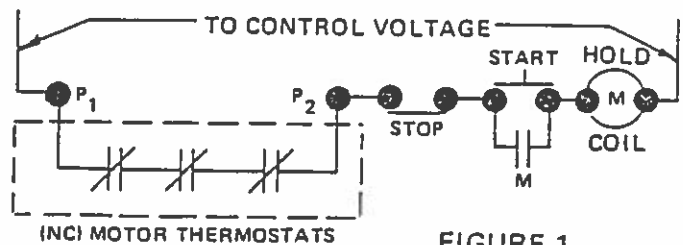
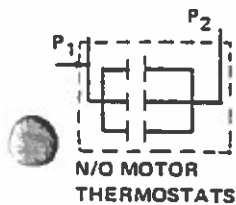

FIGURE 1





Normally Open (N/O) Motor Thermostats are used in conjunction with controls installed by Original Equipment Manufacturers.

FIGURE 1A

## LOCATION

In selecting a location for the unit, first consideration should be given to ventilation. It should be far enough from walls or other objects to permit a free passage of air.

The motor should never be placed in a room with a hazardous process, or where flammable gasses or combustible material may be present unless it is specifically designed for this type of service.

1. Dripproof motors are intended for use where atmosphere is relatively clean, dry and non-corrosive.
  - a. When atmosphere is worse than above request approval of motor for use intended.
2. Totally enclosed motors may be installed where dirt, moisture and corrosion are present, or in outdoor locations.
3. Explosion proof motors are built for use in hazardous locations as indicated by Underwriters' label on motor. Consult your local governmental inspection agency for guidance.

The ambient temperature of the air surrounding the motor should not exceed 40° C or 104° F unless the motor has been especially designed for high ambient temperature applications. The free flow of air around the motor should not be obstructed.

## FLOOR MOUNTING

Motors should be provided with a firm, rigid foundation, in the plane of four mounting stud pads flat within .010" for 56 to 210 frame; .015" from 250 through 680 frame. This may be accomplished by shims under the motor feet. For special isolation mounting, contact a Marathon Electric sales representative.

Before connecting motor to the load by belt drive or direct coupling, verify manually that the rotor turns freely and does not rub.

## V-BELT DRIVE

1. Align sheaves carefully to avoid axial thrust on motor bearing. The drive sheave on the motor should be centered on the shaft extension.
2. When adjusting belt tension by pulling on the feet make sure the motor is secured by all mounting bolts before tightening belts.
3. Adjust belt tension to belt manufacturers recommendations.
4. Sheaves should be in accordance to NEMA Spec. MG-1 or as approved by the manufacturer for a specific application.

## DIRECT CONNECTED DRIVE

Flexible or solid shaft couplings must be properly aligned for satisfactory operation. On flexible couplings, the clearance between the ends of the shafts should be in accordance with the coupling manufacturer's recommendations or NEMA standards for end play and limited travel in coupling.

ANGULAR MISALIGNMENT and RUN-OUT between direct connected shafts will cause increased bearing loads and vibration even when the connection is made by means of a flexible coupling.

To check for ANGULAR MISALIGNMENT, clamp the dial indicator to one coupling hub and place the finger or button of the indicator against the finished face of the other hub as

shown in diagram 1. Set the dial at zero.

Rotate one shaft, keeping the indicator button at the reference mark on the coupling hub, and note the reading on the indicator dial at each revolution.

ANGULAR MISALIGNMENT OF THE SHAFTS MUST NOT EXCEED A TOTAL INDICATOR READING OF .002 INCH FOR EACH INCH OF DIAMETER OF THE COUPLING HUB.

After the shafts have been checked for angular misalignment and are parallel within the limits specified in the preceding paragraph, check the shaft for RUN-OUT to assure concentricity of the shafts. Clamp the indicator button on the machined diameter of the other hub as shown in diagram II. Set the dial at zero.

Rotate one shaft, keeping the indicator button at the reference mark on the hub and note the reading on the indicator dial at each revolution.

TOTAL RUN-OUT BETWEEN THE HUBS SHOULD NOT EXCEED .002 INCH.

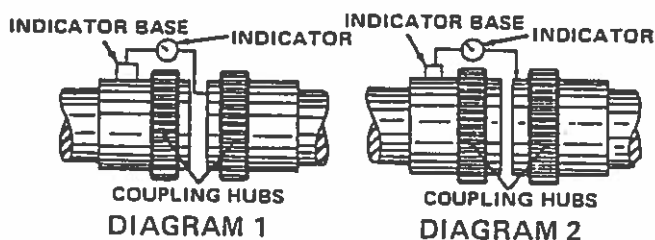

Rotating parts such as couplings, external fans, unusual shaft extensions should be permanently guarded against accidental contact with clothing or body extremities.

## ELECTRICAL CONNECTIONS

1. All wiring, fusing, and grounding must comply with National Electrical Codes and local requirements.
2. To determine proper wiring, rotation and voltage connections, refer to the information and diagram on the nameplate, separate connection plate or decal. If the plate or decal has been removed, make inquiries of the manufacturer.
3. Use the proper size of line current protection and motor controls as required by the National Electrical Code and local codes. Recommended use is 125% of full load amps as shown on the nameplate for motors with 40° C ambient and a service factor over 1.0. Recommended use is 115% of full load amps as shown on the nameplate for all other motors. Do not use protection with larger capacities than recommended. All three phase motors must have all three phases protected.

## CHANGING ROTATION

1. The key must be removed from the motor shaft before starting. Keep hands and clothing away from rotating parts.
2. Before the motor is used as a power source for equipment, determine the proper rotation of the driven unit.
3. Before applying a load to the motor, determine that the motor and driven unit are in the same rotation sequence.
4. Checking rotation can be done by jogging or bumping. Applying power to the motor leads for a short period of time, enough to just get motor shaft to rotate a slight amount to observe shaft rotating direction.
5. Three phase interchange any two (2) of the line leads with the motor lead connections shown on the nameplate, separate connection plate or decal.

## PART WINDING STARTING

On those motors used for part winding starting, the elapsed time on the first step should be kept as short as possible and should not exceed 5 seconds. It is recommended that this time be limited to 2 seconds.

# OPERATION

## BEFORE INITIAL STARTING

1. If a motor has become damp in shipment or in storage, it is advisable to measure insulation resistance of the stator winding.

$$\text{Minimum Insulation Value in Megohms} = \frac{\text{Rated Voltage}}{1000} + 1$$

2. If insulation resistance is low, dry out the moisture in one of the following ways:
  - a. Bake in oven at temperature not more than 90° C (194° F) until insulation resistance is practically constant.
  - b. Enclose motor with canvas or similar covering, leaving a hole at the top for moisture to escape, and insert heating units or lamps.
  - c. Pass a current at low voltage (rotor locked) through the stator winding. Increase the current gradually until the winding temperature, measured with a thermometer, reaches 90° C (194° F). Do not exceed this temperature.
3. See that voltage and frequency stamped on motor and control nameplates correspond with that of the power line.
4. Check all connections to the motor and control with the wiring diagram.
5. Be sure rotor turns freely and does not rub when disconnected from the load. Any foreign matter in the air gap should be removed.
6. Leave the motor disconnected from the load for the initial start; it is desirable to operate the motor without load for about one hour to test for any localized heating in bearings and windings. Check for proper rotation.

## COLLECTOR RINGS (Wound Rotor Motors Only)

The collector rings are sometimes slushed at the factory to protect them while in stock and during shipment. The brushes have been fastened in a raised position. Before putting the motor into service, the slushing should be removed with carbon tetrachloride or some other cleaning fluid that will not attack insulation; the rings polished with fine sandpaper; and the brushes should be set down on the collector surface. Keep the rings clean and maintain their polished surfaces. Ordinarily, the rings will require only occasional wiping with a piece of canvas or non-linting cloth. Do not let dust or dirt accumulate between the collector rings.

## BRUSHES (Wound Rotor Motors Only)

See that the brushes move freely in the holders and at the same time make firm, even contact with the collector rings. The pressure should be between 2 and 3 pounds per square inch of brush surface.

When installing new brushes, fit them carefully to the collector rings. Be sure that the copper pigtail conductors are securely fastened to, and make good contact with, the brushholders.

## ALLOWABLE VOLTAGE AND FREQUENCY RANGE

If voltage and frequency are within the following range, motors will operate, but with somewhat different character-

istics than obtained with correct nameplate values.

1. Voltage: Within 10% above or below the value stamped on the nameplate.
2. Frequency: Within 5% above or below the value stamped on the nameplate.
3. Voltage and Frequency together: Within 10% (providing frequency above is less than 5%) above or below values stamped on the nameplate.

## CLEANLINESS

Keep both the interior and exterior of the motor free from dirt, water, oil and grease. Motors operating in dirty places should be periodically disassembled and thoroughly cleaned.

## CONDENSATION DRAIN PLUGS

If motor is totally enclosed fan cooled or non ventilated and is equipped with automatic drain plugs, they should be free of oil, grease, paint, grit and dirt so they don't clog up.

## LUBRICATION

This motor has been properly lubricated at the time of manufacture and is not necessary to lubricate at time of installation. If the motor has been in storage for a period of six months or greater, relubricate before starting.

To lubricate:

1. Stop motor
2. Wipe clean all grease fittings. (Filler and drain.)
3. Remove filler and drain plugs. A and B (See figure 2.)
4. Free drain hole of any hard grease (use piece of wire if necessary).
5. Add Grease\* using a low pressure grease gun.
6. Start motor and let run for approximately 30 minutes.
7. Stop motor, wipe off any drained grease, and replace filler and drain plugs.
8. Motor is ready for operation.

\* The amount of grease added is very important. Only enough grease should be added to replace the grease used by the bearing. Too much grease can be as harmful as insufficient grease. Every four years (every year in the case of severe duty) motors with open bearings should be thoroughly cleaned, washed and repacked with grease. The quantity of grease is important. The grease cavity should be filled 1/3 to 1/2 full. Too much grease is as detrimental as insufficient grease. (See figures 3, 4, 5.)

### NOTE

If lubrication instructions are shown on motor, they will supersede this general instruction.

FIGURE 2

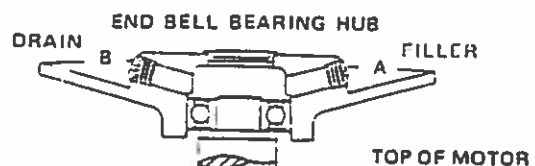

FIGURE 3

RECOMMENDED GREASES

INSULATION CLASS SHOWN ON NAMEPLATE	GREASE DESIGNATION	GREASE SUPPLIER
B or F	Chevron SRI-2	Standard Oil of California or equivalent

**WARNING**

Disconnect power before working on motor driven equipment. Motors with automatic thermal protectors will automatically restart when the protector temperature drops sufficiently. Do not use motors with automatic thermal protectors in applications where automatic restart will be hazardous to personnel or equipment.

FIGURE 4

RELUBRICATION PERIOD

Frame Size @ 900, 1200 & Var. Speed	Relub. Period @ Std. Conditions (8 hr./day, normal to light loading 100° F max. amb.)	Severe Conditions	Extreme Conditions
140-180	4.5 Years	18 Months	9 Months
210-280	4 Years	16 Months	8 Months
320-400	3.5 Years	14 Months	7 Months
440-508	3.0 Years	12 Months	6 Months
510	2.5 Years	11½ Months	6 Months
Frame Size @ 1800 RPM	Std. Conditions	Severe Conditions	Extreme Conditions
140-180	3 Years	1 Year	6 Months
210-280	2.5 Years	10½ Months	5½ Months
320-400	2.0 Years	9 Months	4½ Months
440-508	1.5 Years	8 Months	4 Months
510	1 Years	6 Months	3½ Months
All Motors over 1800 RPM	6 Months	3 Months	3 Months

For roller bearings: Divide above times by 3.

**STANDARD CONDITIONS:** Eight hours per day, normal or light loading, clean 100° F maximum ambient.

**SEVERE CONDITIONS:** Twenty-four hours per day operation, or shock loadings, vibration, or in dirt or dust at 100° to 150° F ambient.

**EXTREME CONDITIONS:** Heavy shock or vibration, dirt or dust at 100° to 150° F ambient.

TROUBLES

If trouble is experienced in the operation of the motor, make sure that:

1. The bearings are in good condition and operating properly.
2. There is no mechanical obstruction to prevent rotation in the motor or in the driven load.
3. The air gap is uniform.
4. All bolts and nuts are tightened securely.
5. Proper connection to drive machine or load has been made.

In checking for electrical troubles, be sure that:

1. The line voltage and frequency correspond to the voltage and frequency stamped on the nameplate of the motor.
  2. The voltage is actually available at motor terminals.
  3. The fuses and other protective devices are in proper condition.
  4. All connections and contacts are properly made in the circuits between the control apparatus and motor.
- Never attempt to measure the temperature rise of a motor by hand. Temperature rise must be measured by thermometer, resistance, or by imbedded detector or thermocouple.

**CAUTION**

1. Do not perform any maintenance or service on this motor before disconnecting the power source.
2. Discharge all capacitors before servicing motor.
3. Always keep hands and clothing away from moving parts.
4. Electrical repairs should be performed by trained and qualified personnel only.
5. Failure to follow instructions and safe electrical procedures could result in serious injury.
6. If safety guards are required, be sure the guards are in use.

FIGURE 5

AMOUNT OF GREASE REQUIRED WHEN REGREASING

BEARING NUMBER	AMOUNT (IN.3)	APPROX. EQUIV. TEASPOONS	BEARING NUMBER	AMOUNT (IN.3)	APPROX. EQUIV. TEASPOONS
203	.15	.5 Tsp.	222	3.0	10.0 Tsp.
205	.27	.9 Tsp.	307	.53	1.8 Tsp.
206	.34	1.1 Tsp.	308	.66	2.2 Tsp.
207	.43	1.4 Tsp.	309	.81	2.7 Tsp.
208	.52	1.7 Tsp.	310	.97	3.2 Tsp.
209	.61	2.0 Tsp.	311	1.14	3.8 Tsp.
210	.72	2.4 Tsp.	312	1.33	4.4 Tsp.
212	.95	3.1 Tsp.	313	1.54	5.1 Tsp.
213	1.07	3.6 Tsp.	314	1.76	5.9 Tsp.
216	1.49	4.9 Tsp.	316	2.24	7.4 Tsp.
219	2.8	7.2 Tsp.	318	2.78	9.2 Tsp.

These instructions do not cover all details or variations in equipment nor provide for every possible condition to be met in connection with installation, operation or maintenance. Should additional information be desired for the purchaser's purposes, the matter should be referred to the nearest Marathon Electric Manufacturing Corp. sales office listed on the back page.

### MOTOR TROUBLE SHOOTING CHART

Your motor service and any trouble shooting must be handled by qualified persons who have proper tools and equipment.

TROUBLE	CAUSE	WHAT TO DO
Motor fails to start	Blown fuses	Replace fuses with proper type and rating.
	Overload trips	Check and reset overload in starter.
	Improper power supply	Check to see that power supplied agrees with motor nameplate and load factor.
	Improper line connections	Check connections with diagram supplied with motor.
	Open circuit in winding or control switch	Indicated by humming sound when switch is closed. Check for loose wiring connections. Also see that all control contacts are closing.
	Mechanical failure	Check to see if motor and drive turn freely. Check bearings and lubrication
	Short circuited stator	Indicated by blown fuses. Motor must be rewound.
	Poor stator coil connection	Remove end bells, locate with test lamp.
	Rotor defective	Look for broken bars or end rings.
Motor may be overloaded	Reduce load.	
Motor stalls	One phase may be open	Check lines for open phase.
	Wrong application	Change type or size. Consult manufacturer.
	Overload motor	Reduce load.
	Low motor voltage	See that nameplate voltage is maintained. Check connection.
	Open Circuit	Fuses blown, check overload relay, stator and pushbuttons.
Motor runs and then dies down	Power failure	Check for loose connections to line, to fuses and to control.
Motor does not come up to speed	Not applied properly	Consult supplier for proper type.
	Voltage too low at motor terminals because of line drop.	Use higher voltage on transformer terminals or reduce load. Check connections. Check conductors for proper size.
	Starting load too high	Check that load motor is supposed to carry at start.
	Broken rotor bars or loose rotor	Look for cracks near the rings. A new rotor may be required as repairs are usually temporary.
	Open primary circuit	Locate fault with testing device and repair.
Motor takes too long to accelerate	Excess loading	Reduce load.
	Poor circuit	Check for high resistance
	Defective squirrel cage rotor	Replace with new rotor.
	Applied voltage too low	Get power company to increase power tap.
Wrong rotation	Wrong sequence of phases	Reverse connections at motor or at switchboard.
Motor overheats while running under load	Overloaded	Reduce load.
	Frame or bracket vents may be clogged with dirt and prevent proper ventilation of motor.	Open vent holes and check for a continuous stream of air from the motor.
	Motor may have one phase open	Check to make sure that all leads are well connected.
	Grounded coil	Locate and repair
	Unbalanced terminal voltage	Check for faulty leads, connections and transformers.
Motor vibrates after corrections have been made.	Motor misaligned	Realign.
	Weak support	Strengthen base
	Coupling out of balance	Balance coupling.
	Driven equipment unbalanced	Rebalance driven equipment.
	Defective ball bearing	Replace bearing.
	Bearings not in line	Line up properly.
	Balancing weights shifted	Rebalance motor.
	Polyphase motor running single phase	Check for open circuit.
	Excessive end play	Adjust bearing or add washer.
Unbalanced line current on polyphase motors during normal operation.	Unequal terminal volts	Check leads and connections.
	Single phase operation	Check for open contacts.
Scraping noise	Fan rubbing air shield	Remove interference.
	Fan striking insulation	Clear fan.
	Loose on bedplate	Tighten holding bolts.
Noisy operation	Airgap not uniform	Check and correct bracket fits or bearing.
	Rotor unbalance	Rebalance.
Hot bearings general	Bent or sprung shaft	Straighten or replace shaft.
	Excessive belt pull	Decrease belt tension.
	Pulleys too far away	Move pulley closer to motor bearing.
	Pulley diameter too small	Use larger pulleys.
	Misalignment	Correct by realignment of drive.
Hot bearings ball	Insufficient grease	Maintain proper quantity of grease in bearing.
	Deterioration of grease or lubricant contaminated	Remove old grease, wash bearings thoroughly in kerosene and replace with new grease.
	Excess lubricant	Reduce quantity of grease, bearing should not be more than 1/2 filled.
	Overloaded bearing	Check alignment, side and end thrust.
	Broken ball or rough races	Replace bearing, first clean housing thoroughly.

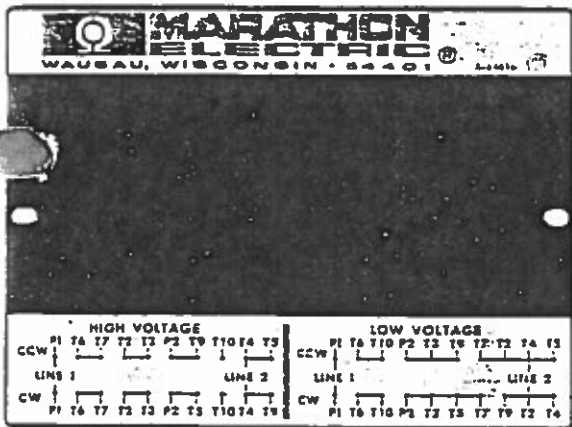

## FOR RENEWAL PARTS

When ordering parts for repair or spares, give description and state quantity of parts desired, together with the complete nameplate data: rating, model and serial number of the motor and all data.

## Sales and Service Assistance

### California

**ANAHEIM**  
625 South Euclid Suite 15  
Anaheim, CA 92802  
Phone: (714) 956-7111

**CASTRO VALLEY**  
20835 Chester Street, Suite B  
Castro Valley, CA 94546  
Phone: (415) 889-1393

### Florida

**MIAMI**  
Alvan C. Chaney & Assoc.  
117 N.E. 54th St.  
Miami, FL 33137  
Phone: (305) 754-8857

### Illinois

**CHICAGO**  
680 Greenleaf Avenue  
Elk Grove Village, IL 60007  
Phone: (312) 593-6500

### Indiana

**INDIANAPOLIS**  
6520 E. 82nd Street,  
Indianapolis, IN 46250  
Phone: (317) 842-4652

### Louisiana

**NEW ORLEANS**  
5622 Perrier Street  
New Orleans, LA 70115  
Phone: (504) 889-5426

### Minnesota

**MINNEAPOLIS**  
8700 West 36th Street  
Minneapolis, MN 55426  
Phone: (612) 935-8424

### New York

**SYRACUSE**  
Room 173 Pickard Building  
5858 East Molloy Road  
Syracuse, NY 13211  
Phone: (315) 454-0994  
454-3130

### Ohio

**CINCINNATI**  
1313 E. Kemper Rd., Suite 104  
Cincinnati, OH 45246  
Phone (513) 671-1677

**CLEVELAND**  
20800 Center Ridge Rd-Suite 400  
Cleveland, OH 44116  
Phone: (216) 331-2910

### Pennsylvania

**BRIDGEVILLE**  
Foster-McClinton, Inc.  
2867 Washington Road  
Bridgeville, PA 15017  
Phone: (412) 941-4800

**FOGELSVILLE**  
55 Snowdrift Road  
Fogelsville, PA 18051  
Phone: (215) 395-6880

### South Carolina

**GREENVILLE**  
100 Executive Center Drive  
Greenville, SC 29615  
Phone: (803) 288-8991  
288-8990

### Tennessee

**NASHVILLE**  
1040 Murfreesboro Road  
Suite 207  
Nashville, TN 37217  
Phone: (615) 366-4262

### Texas

**DALLAS**  
1366 Exchange Drive  
Richardson, TX 75081  
Phone: (214) 699-0251

**HOUSTON**  
5650 Guhn Rd.  
Houston, TX 77040  
Phone: (713) 462-4445

### Washington

**SPOKANE**  
Electro-Power Corp.  
N. 104 Madelia  
P.O. Box 2983  
Spokane, WA 99202  
Phone: (509) 535-2931



100 E. Randolph Street  
Wausau, WI 54401  
Phone: (715) 675-3311